

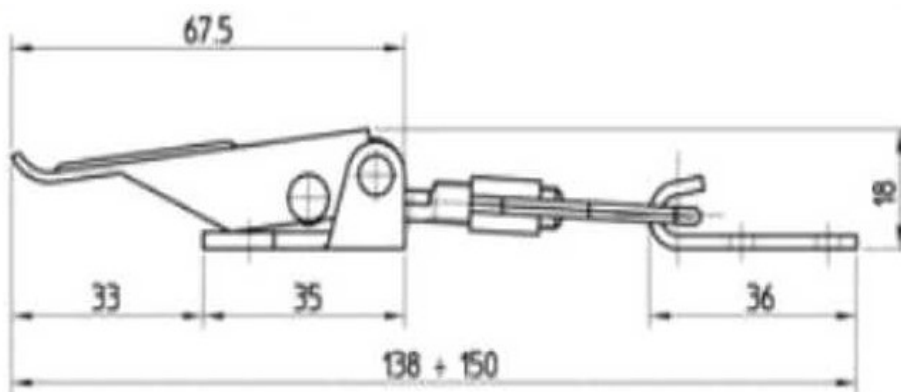

**Concept
Latch Lock & Hinge**

address: 353 Victoria Street, Brunswick, VIC, 3056
phone: 03 9388 2551 **fax:** 03 9387 5758
email: sales@conceptlatch.com.au
web: www.conceptlatch.com.au
ABN: 53 098 642 641

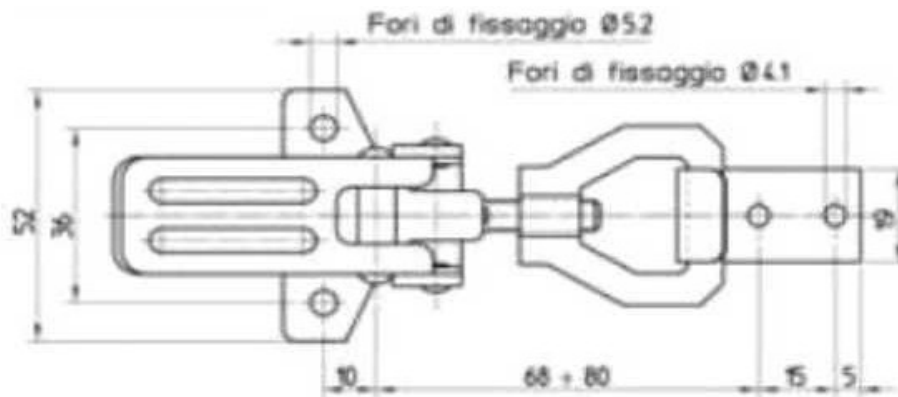

**PART:
2.05.00**

**DESCRIPTION:
ADJUSTABLE TOGGLE LATCH**

**MATERIAL: NICKEL PLATED, ZINC,
STAINLESS STEEL**

**DATE OF DRAWING:
26/07/2011**