

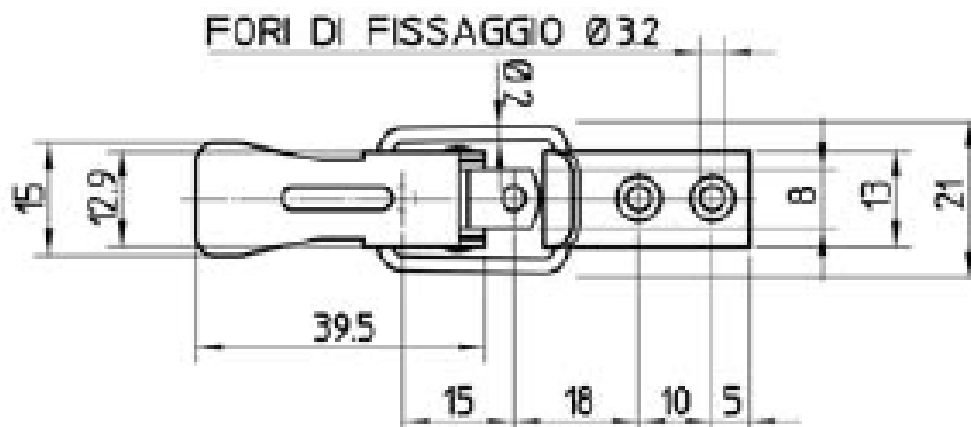

Concept
Latch Lock & Hinge

address: 353 Victoria Street, Brunswick, VIC, 3056
phone: 03 9388 2551 fax: 03 9387 5758
email: sales@conceptlatch.com.au
web: www.conceptlatch.com.au
ABN: 53 098 642 641

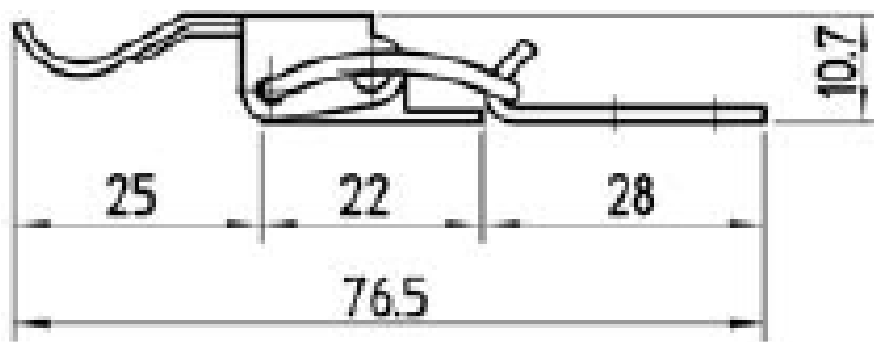

PART: 2.02.00	DESCRIPTION: TOGGLE LATCH	
	MATERIAL: UNPLATED STEEL, NICKEL PLATED, ZINC PLATED, STAINLESS STEEL	DATE OF DRAWING: 27/09/2011