

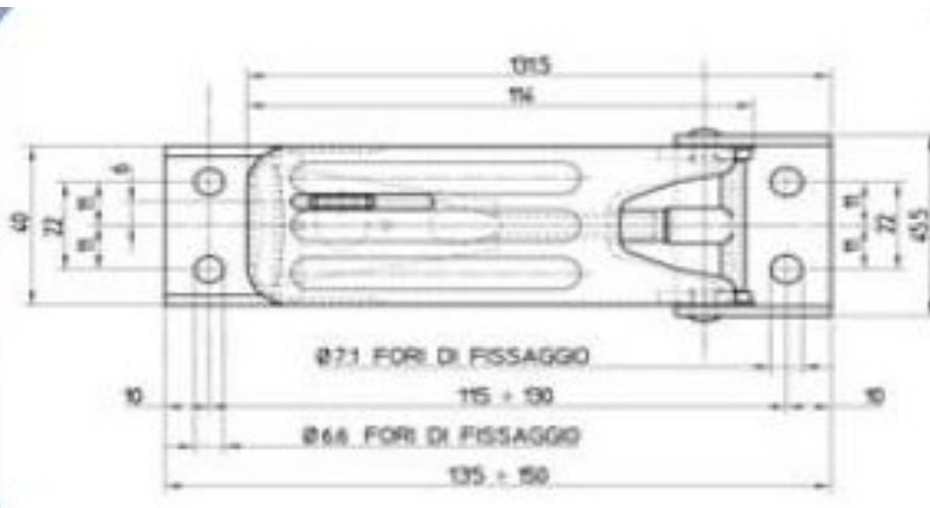

**Concept
Latch Lock & Hinge**

address: 353 Victoria Street, Brunswick, VIC, 3056
phone: 03 9388 2551 fax: 03 9387 5758
email: sales@conceptlatch.com.au
web: www.conceptlatch.com.au
ABN: 53 098 642 641

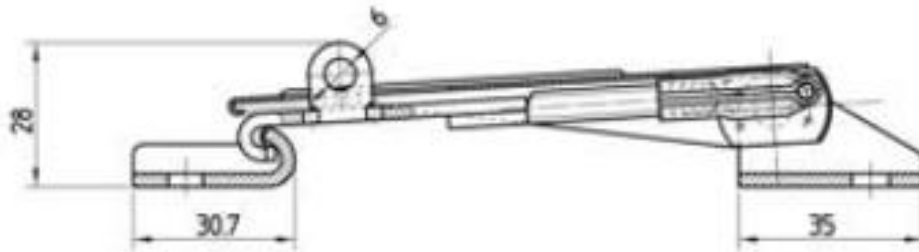
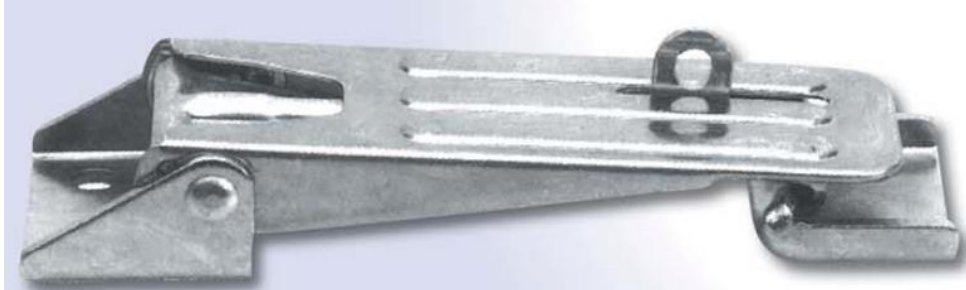

**PART:
2.40.01**

**DESCRIPTION:
HASP TOGGLE LATCH**

MATERIAL: ZINC PLATED STEEL,

**DATE OF DRAWING:
27/09/2011**