

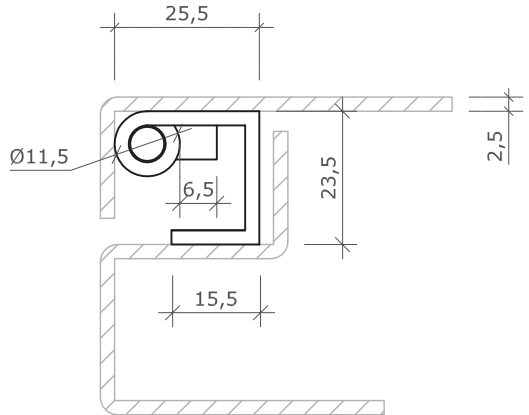

**Concept**  
Latch Lock & Hinge

**address:** 353 Victoria Street, Brunswick, VIC, 3056  
**phone:** 03 9388 2551 fax: 03 9387 5758  
**email:** sales@conceptlatch.com.au  
**web:** [www.conceptlatch.com.au](http://www.conceptlatch.com.au)  
**ABN:** 53 098 642 641

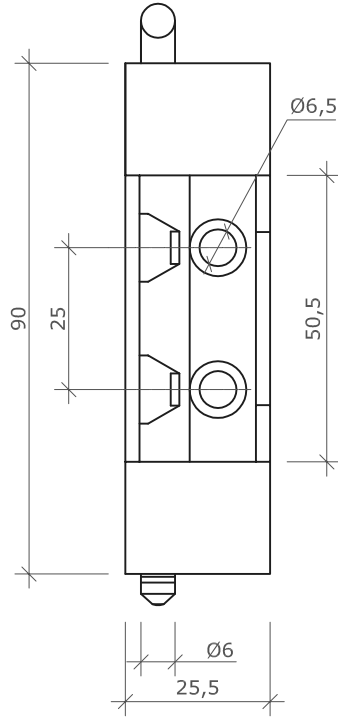

**PART:**  
**DHIM-120**

**DESCRIPTION:** Concealed Hinge, M.S. Pin, Zinc Plated,  
Opening Angle  $120^\circ$

**SCALE:**  
not to scale

**MATERIAL:**  
Zinc Plated

**DATE OF DRAWING:**  
20/09/10