

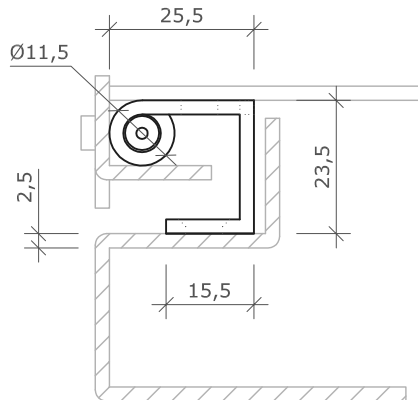

Concept
Latch Lock & Hinge

address: 353 Victoria Street, Brunswick, VIC, 3056
phone: 03 9388 2551 fax: 03 9387 5758
email: sales@conceptlatch.com.au
web: www.conceptlatch.com.au
ABN: 53 098 642 641

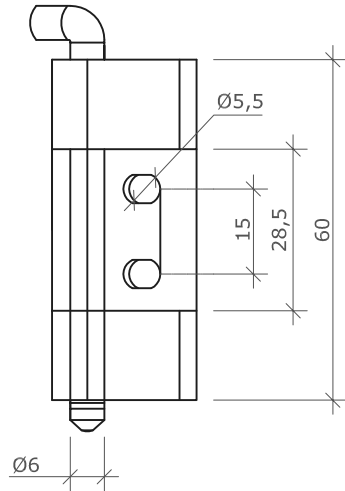

PART:
DHIM-60

DESCRIPTION: **Concealed Hinge, M.S. Pin, Zinc Plated, Opening Angle 120°**

SCALE:
not to scale

MATERIAL:
Zinc Plated

DATE OF DRAWING:
20/09/10