

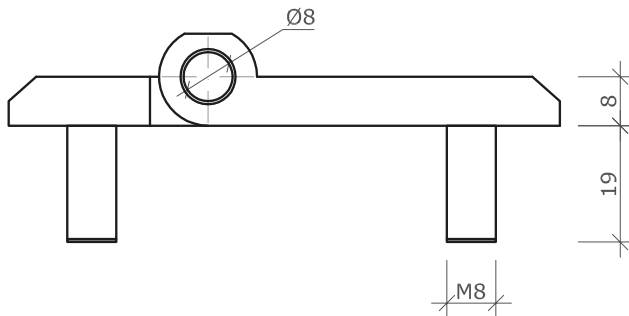

Concept
Latch Lock & Hinge

address: 353 Victoria Street, Brunswick, VIC, 3056
phone: 03 9388 2551 **fax:** 03 9387 5758
email: sales@conceptlatch.com.au
web: www.conceptlatch.com.au
ABN: 53 098 642 641

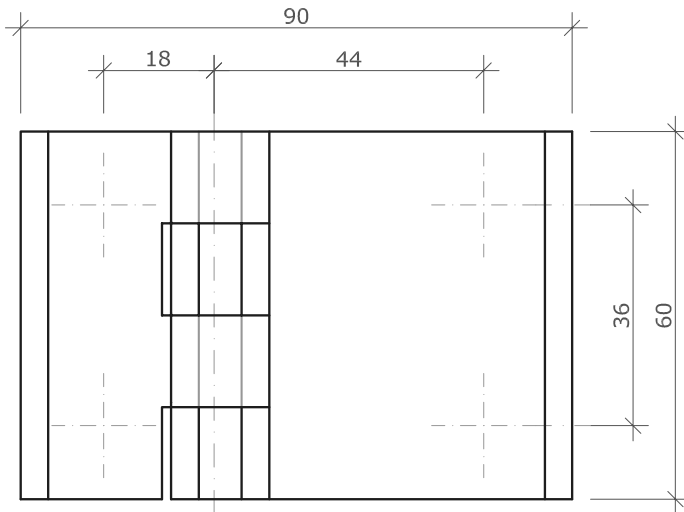

PART:
DHFM-6090-S

DESCRIPTION: Flat Hinge, S.S. Pin, Black Powder Coated,
Opening Angle 180°, Stud Mounted

SCALE:
not to scale

MATERIAL:

DATE OF DRAWING:
26/09/10