

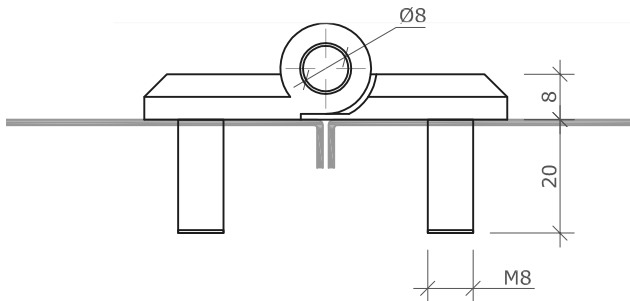

Concept
Latch Lock & Hinge

address: 353 Victoria Street, Brunswick, VIC, 3056
phone: 03 9388 2551 fax: 03 9387 5758
email: sales@conceptlatch.com.au
web: www.conceptlatch.com.au
ABN: 53 098 642 641

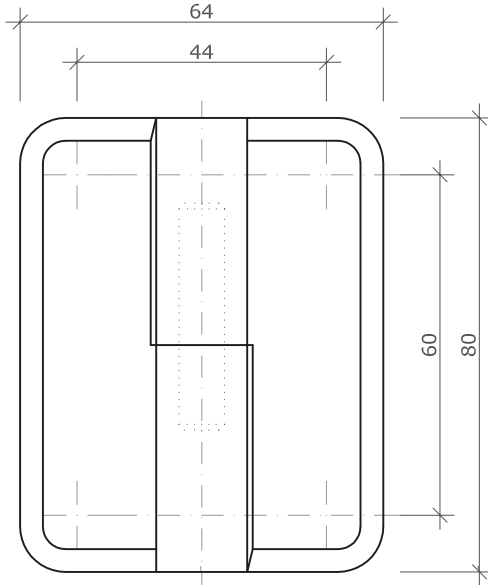

* Available in Left Hand and Right Hand - please specify

PART:
DHFM-8060-PC

DESCRIPTION: **Lift-Off Hinge, S.S. Pin, Black Powder Coated, Opening Angle 180°**

SCALE:
not to scale

MATERIAL:

DATE OF DRAWING:
26/09/10