

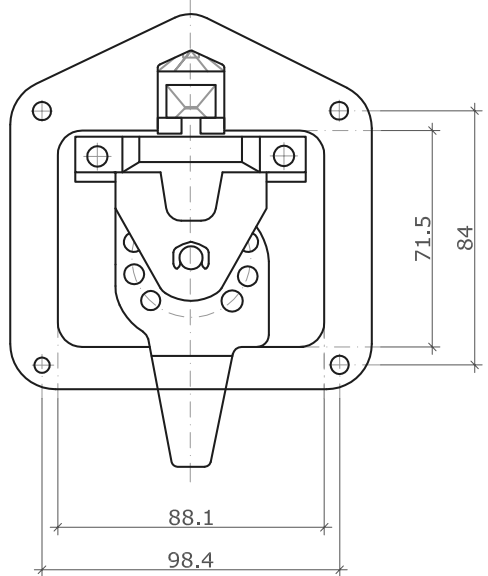

Concept
Latch Lock & Hinge

address: 353 Victoria Street, Brunswick, VIC, 3056
phone: 03 9388 2551 fax: 03 9387 5758
email: sales@conceptlatch.com.au
web: www.conceptlatch.com.au
ABN: 53 098 642 641

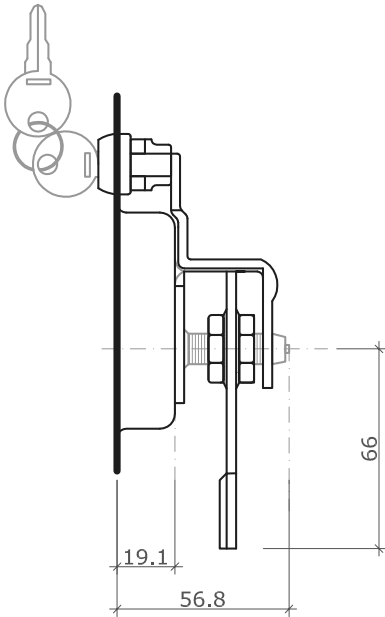
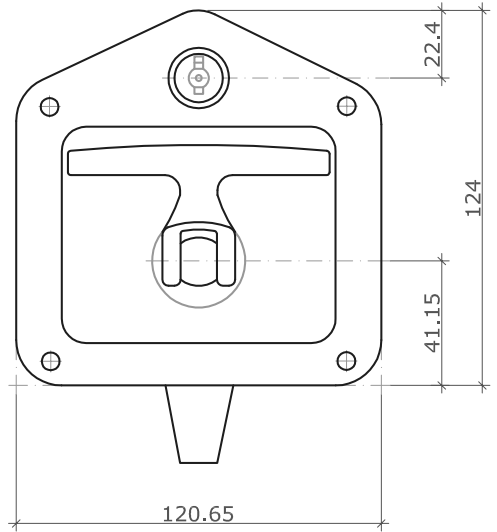

*Available in following key combinations: CH501, CH502, CH505, CH510, CH525

PART: 10502SS	DESCRIPTION: Drop-T Cam Action Latch - Hole Mounting	
SCALE: not to scale	MATERIAL: Stainless Steel	DATE OF DRAWING: 10/12/10