

Designing SLIDES into Electronic Enclosures

An overview of
electronic enclosure
construction and
components

Accuride[®]

Designing **SLIDES** into **Electronic Enclosures**

Table of Contents

Cabinets and Rails	1
Cabinet Rail Construction	3
Chassis	5
Slide Selection Criteria	6
Bracket-to-Rail Mounting	8
Calculating Overall Slide and Bracket Thickness	9
Slide Position on the Chassis	11
Locating/Transferring the Slide Hole Pattern to the Chassis	13
Component Assembly	14
Bracket and Bar Nut Comparisons	15
Glossary	16

DESIGNING SLIDES INTO ELECTRONIC ENCLOSURES

There are two main aspects to consider when designing slides into electronic enclosures: the cabinet construction and the chassis (or drawer). The attributes of these components affect the overall enclosure configuration and the selection of slides, brackets and cable carriers.

CABINETS & RAILS

Cabinets vary according to manufacturer and the intended use of the cabinet. Each manufacturer may have unique rail thicknesses, shapes, materials and placement. Since the slides mount to the cabinet rails and the chassis mounts to the slide, the variances in construction have a significant affect on the enclosure design.

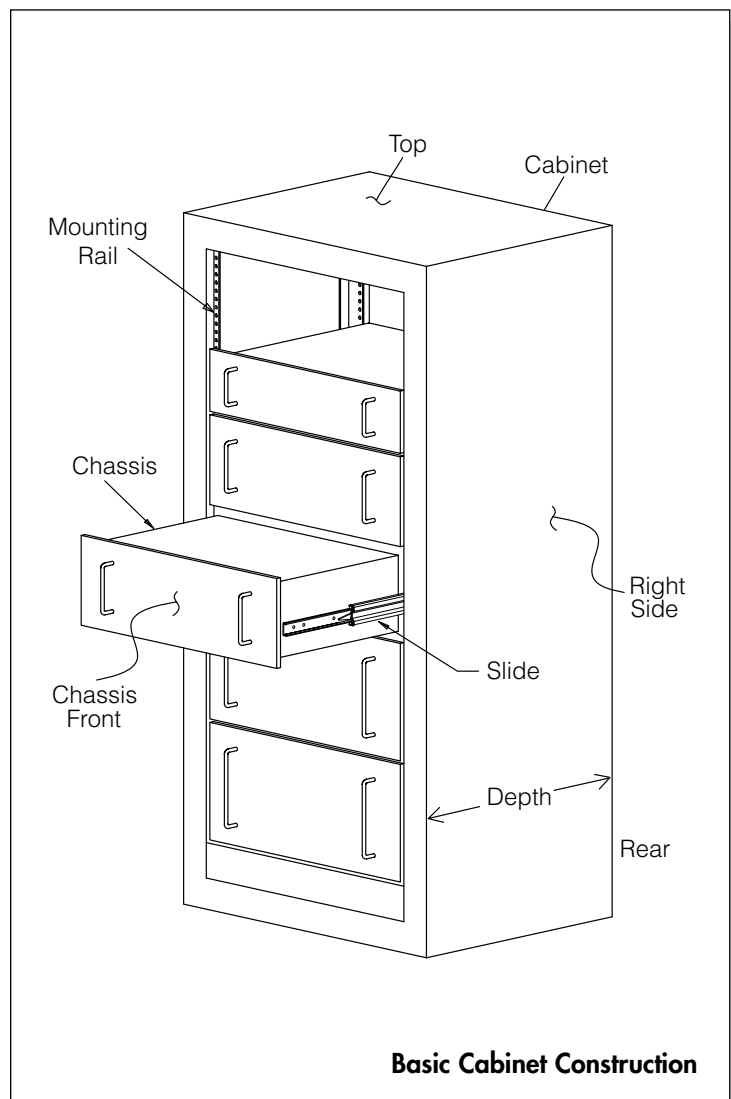

Basic EIA cabinet construction details

- Cabinets contain four or more rails (columns, uprights or struts). The enclosure may or may not have a surrounding skin
- There are front rails, rear rails, and optional mid-rails
- Rail mounting patterns are based on standard EIA specifications
- There is no limitation on overall cabinet height.

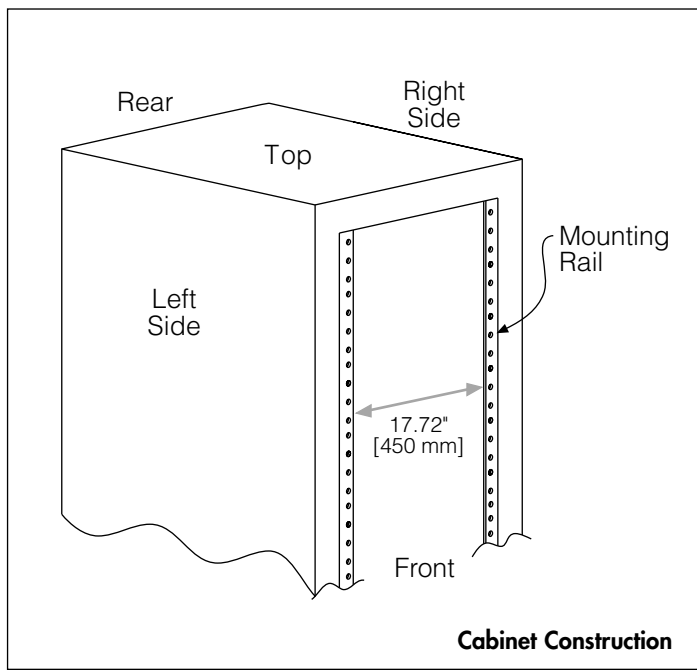
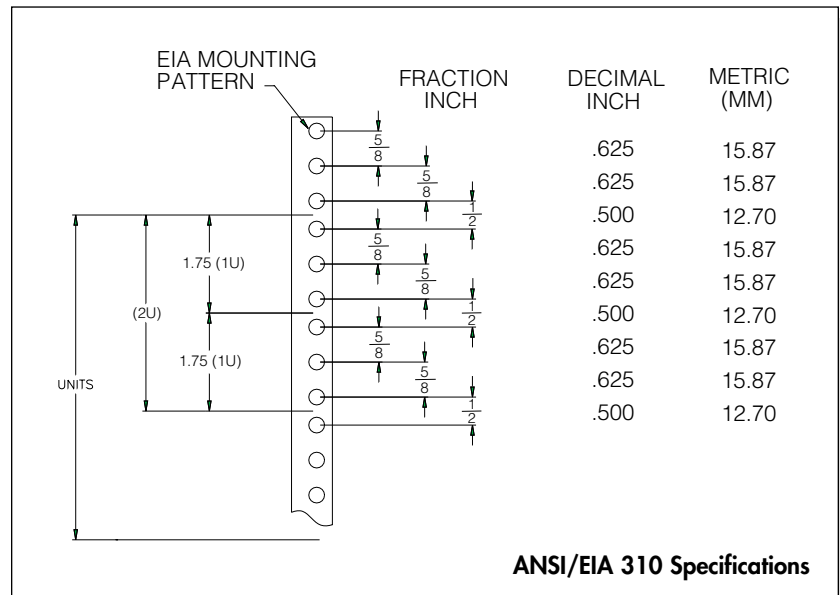

Most electronic cabinets/enclosures are based on dimensional guidelines as illustrated in the ANSI/EIA 310 Specifications.

- A standard 17.72" [450 mm] opening is the minimum width between the rails.
- Rails carry a repetitive pitch pattern of mounting holes.
- 1.75" [44.45 mm] or "1U" is the universal spacing increment and nominal height for drawers.

CABINET RAIL CONSTRUCTION

Generally, cabinet rail construction methods fall into the following groups:

- **Non-Adjustable Rails**

Cabinet construction that provides a set distance from front rail to rear rail.

- **Adjustable Rails**

Cabinet construction that allows the end-user to relocate either front and/or rear rails to an alternate distance from front to rear.

- **Mid Rails**

Cabinet is constructed with an additional set of rails, either adjustable or fixed to provide an alternate mounting distance to accommodate both short and deep slide lengths or various chassis depths.

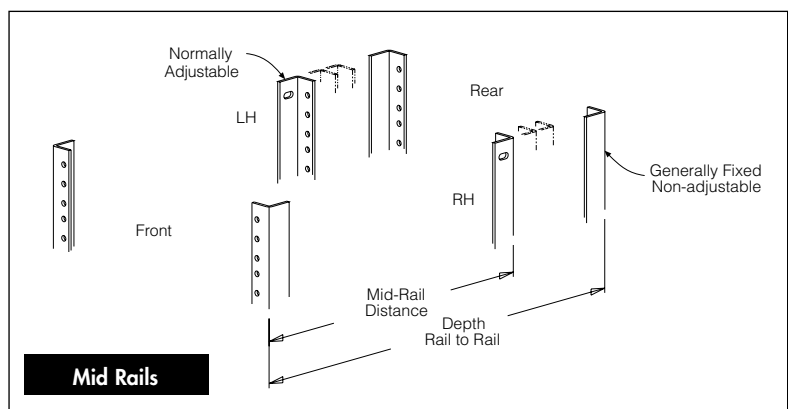
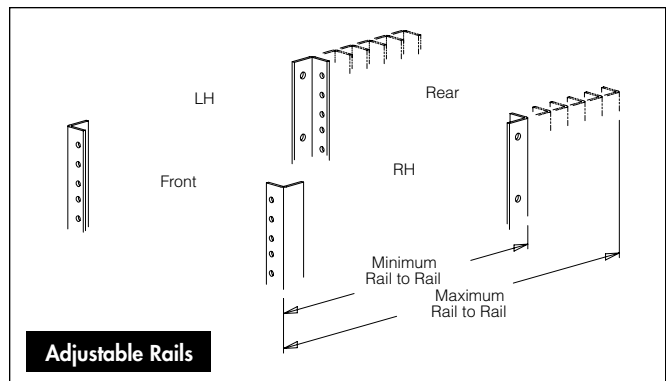
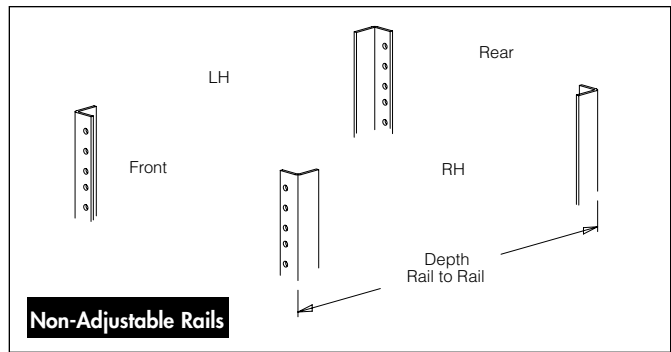

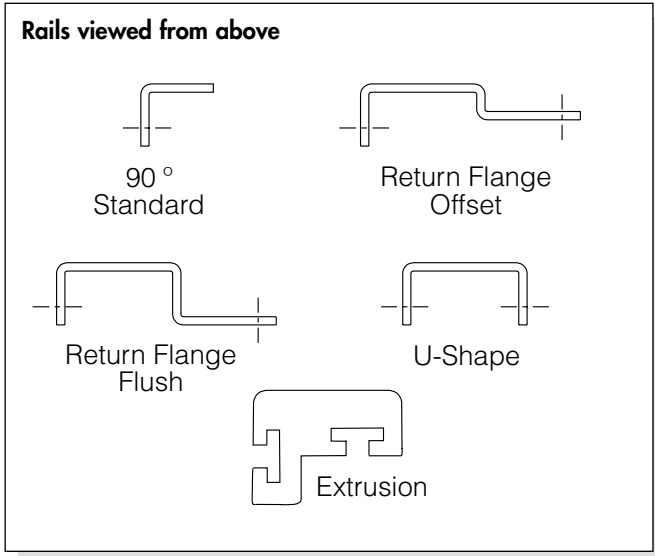

Rail Configurations

Rails may also be referred to as columns, uprights, or struts. See the illustration at left for examples of popular configurations and the terms generally applied to these column shapes.

- 90 degree standard
- Return flange offset
- Return flange flush
- U-shaped
- Extrusion

Mounting Holes

In addition to rail or column configuration differences, there are several types of mounting holes and locations. The mounting hole pattern is visually apparent on the front face of the cabinet column and often appears on other areas of the column as well. Generally, only one method will apply throughout the cabinet.

It is important to consult the specific supplier for exact details on the type of mounting holes offered on the cabinet.

- Through hole
- Tapped hole
- Countersunk hole
- Window/square hole

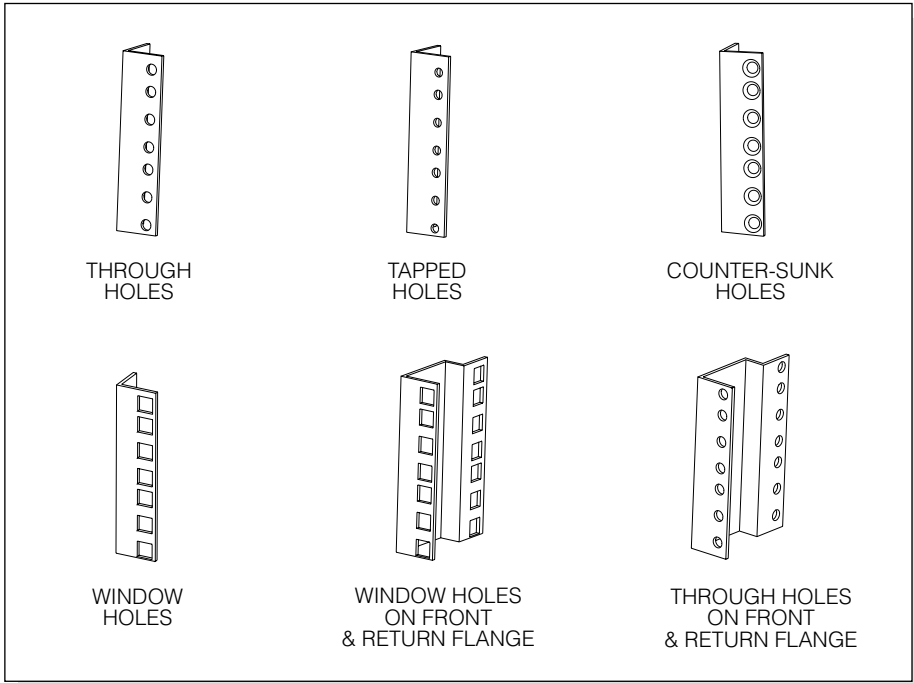

CHASSIS

Chassis is the term for an electronic drawer. The height of a chassis is based on a nominal EIA unit increment of 1.75" [44.45 mm].

Each increment is referred to as a "U". The minimum measure of a chassis is 1U, with subsequent measures expressed as follows: 2U (3.50") [88.90 mm], 3U (5.25") [133.35 mm], etc.

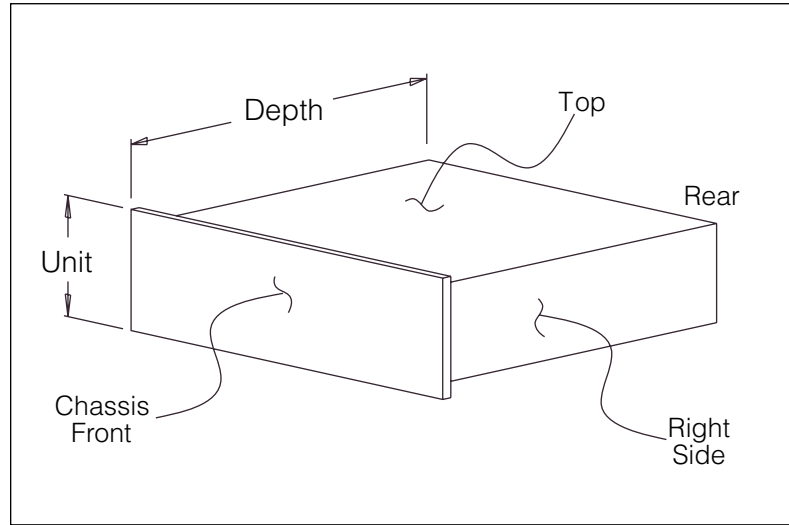

The actual height differs from the nominal height. See the chart below for specific measures.

Definition of units		
EIA Unit	Nominal Height	Maximum Actual Height
1U	1.75" [44.45 mm]	1.72" [43.69 mm]
2U	3.50" [88.90 mm]	3.47" [88.14 mm]
3U	5.25" [133.35 mm]	5.22" [132.59 mm]
4U	7.00" [177.80 mm]	6.97" [177.04 mm]
N (number of) Units	N Units x 1.75" [44.45 mm]	N Units x 1.75" [44.45 mm] - .03" [.8 mm]

SLIDE SELECTION CRITERIA

Selecting the correct Accuride slides and bracketry is based on the following criteria:

- Height of drawer
- Anticipated chassis load
- Amount of chassis travel
- Overall depth of cabinet
- Mounting rail-to-rail distance
- Slide to cabinet mounting bracketry
- Accessories on slide (locking, disconnect, hole pattern)

Anticipated chassis load

Identifying the chassis load will narrow the range of slide models suitable to the application.

Slide load ratings are based on **dynamic** loading, which is continuous motion both out and into the cabinet.

- Load ratings for slides in electronic enclosure applications are based on 2,000 cycles
- One cycle is considered the distance from fully closed to fully opened to fully closed in one motion.
- The cycle speed is generally based on 10–12 cycles per minute.

All Accuride slides accept a static overload of 2 times the indicated load rating as a margin of safety when the slide is fully extended.

Consult Accuride for additional test information for shock and vibration, momentary, seismic, or other special requirements.

Amount of chassis travel

Determining the distance the chassis will be required to travel (the relationship between the back of the chassis and the front of the cabinet) will help establish whether a two- or three-section slide is best suited for a particular application.

Two-section slides provide **3/4 travel**. In other words, the drawer opens approximately three-quarters of the total slide length.

Three-section slides offer **full extension** or **over travel**; the drawer opens the same amount or more than the length of the slide.

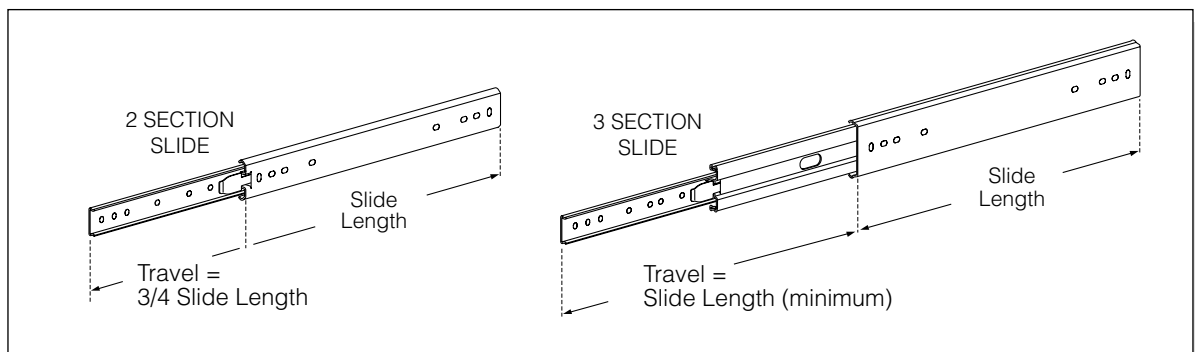

Overall Cabinet Depth

The depth of the cabinet will also determine slide length and corresponding travel required for the application. The following factors should be considered when measuring:

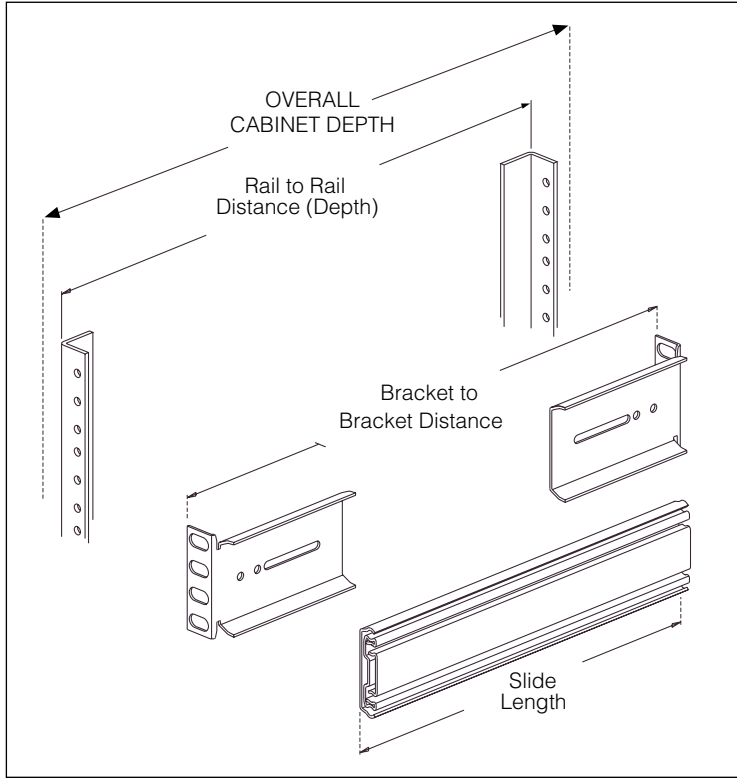

- Cabinet depth is measured overall from the front of the cabinet to the rear. It is greater than the *mounting rail distance*, which is measured from the front rail to the rear rail.
- NOTE: Rail-to-rail distance can be measured from outside to outside or inside to inside of rail surfaces.
- If mounting to a mid rail, the distance will be less than the distance from the front rail to the rear rail.
- A wide variation of cabinet depths and rail-to-rail distances exist. Consult cabinet manufacturer for the exact dimensions of the cabinet.

Slide to cabinet mounting bracketry

Accuride provides several lengths of brackets to meet specific cabinet mounting depths. Many of the Accuride brackets can be installed at a distance less than or greater than the slide length.

Extension brackets accommodate a greater mounting distance beyond the slide length.

Screws go through brackets and cabinet and can be fully tightened using an accessory bar nut.

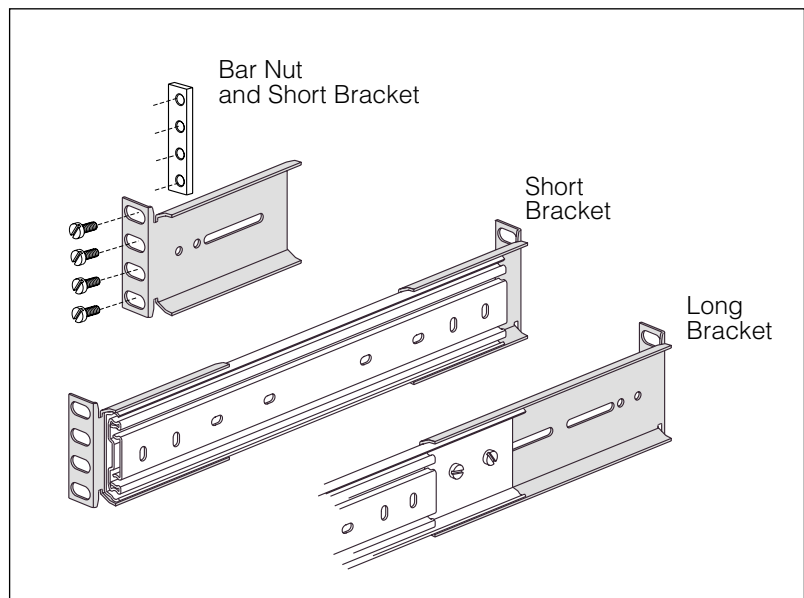

BRACKET-TO-RAIL MOUNTING

The chart below outlines which side of the cabinet rail surface the bracket should be mounted to according to the EIA rail style and accessories used.

EIA Rail Style	Mounting	Accessory	Mounting Rail Surface
Tapped	Bracket	None	Outside
Through Hole	Bracket	Bar Nut	Inside or Outside
Through Hole	Bracket	Clip Nut	Outside
Window	Bracket	Bar Nut	Inside or Outside
Window	Bracket	Clip Nut	Outside
Window	Bracket	Cage Nut	Outside

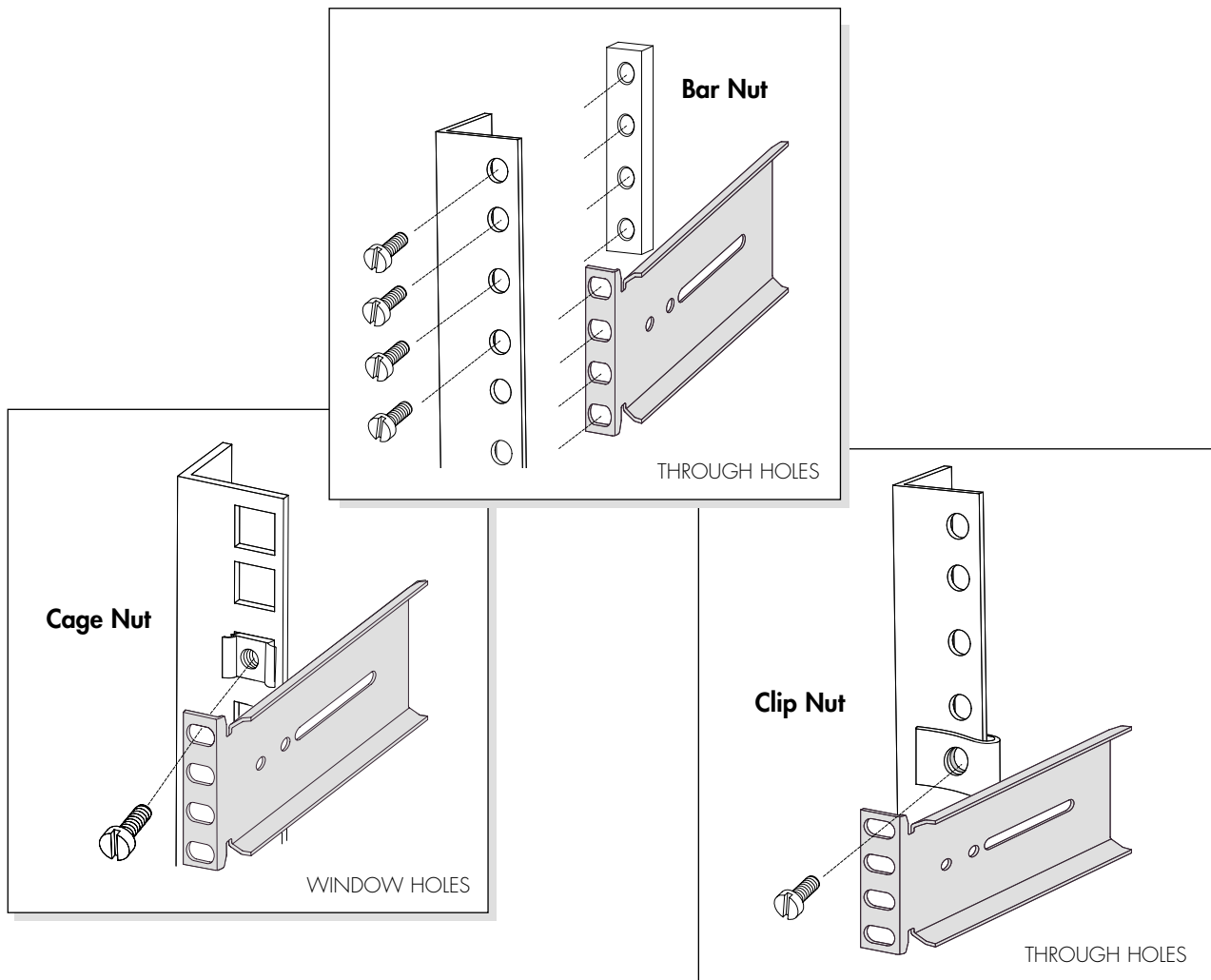

CALCULATING OVERALL SLIDE AND BRACKET THICKNESS

The Accuride slide is the link between the cabinet and chassis; therefore accurate width dimensions are mandatory for proper slide movement and installation. It is important to remember that adding mounting brackets increases the overall slide width.

There are two crucial calculations required to determine the slide width suitable for the application:

Functional Space

The area between the rail and the chassis side. Consider the overall slide thickness, or extending slide members' thickness *plus* the bracket thickness.

Available Space

The area within the cabinet to mount non-moving portions of slides and/or brackets.

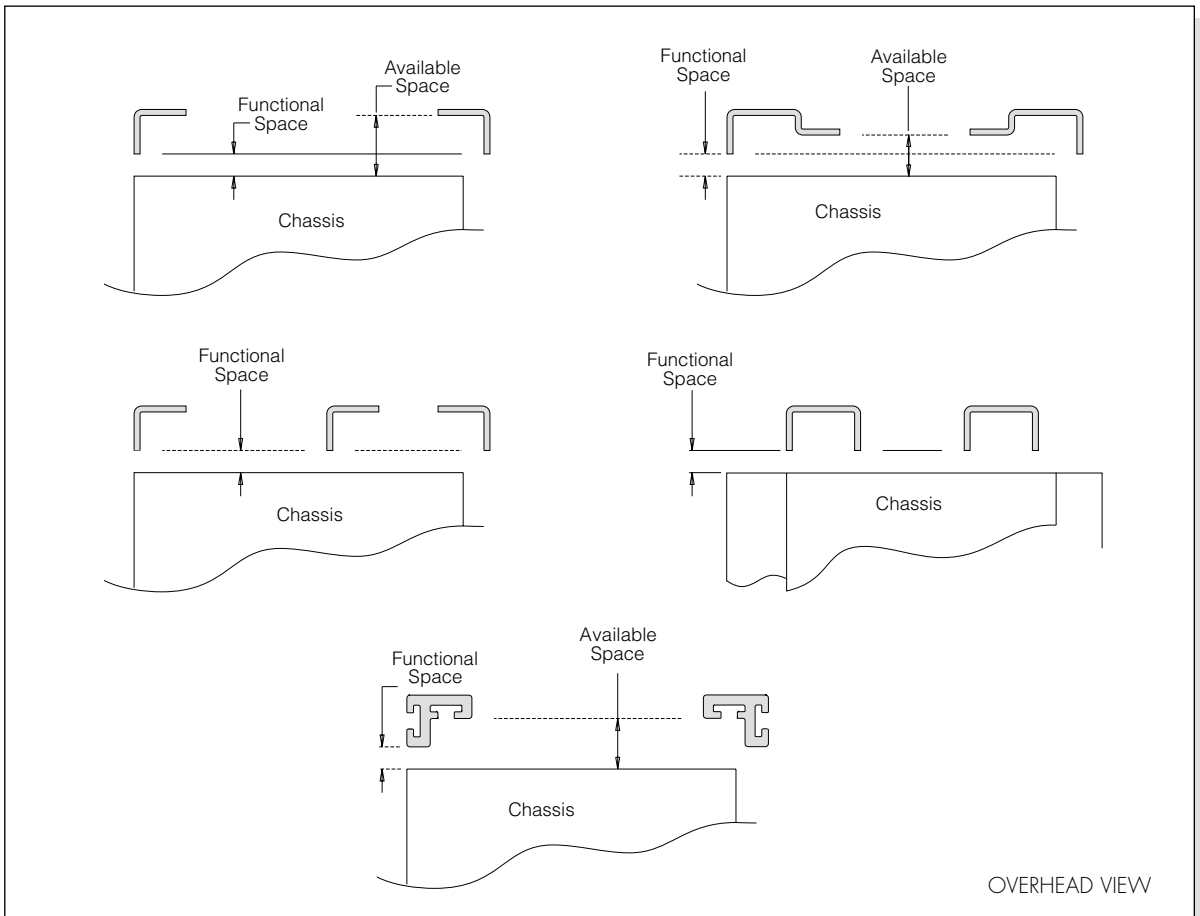
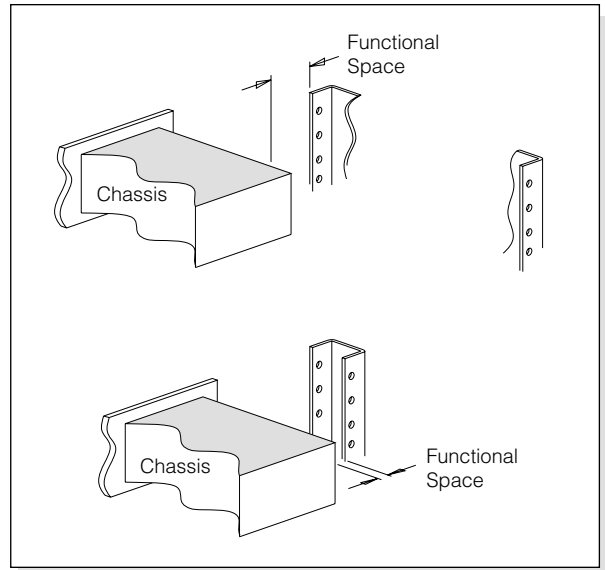

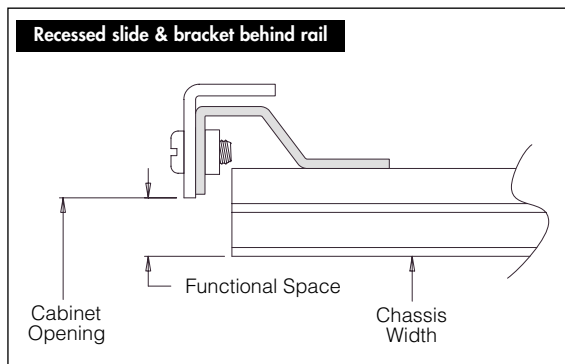
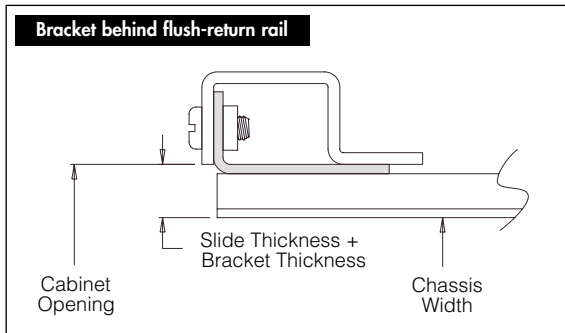
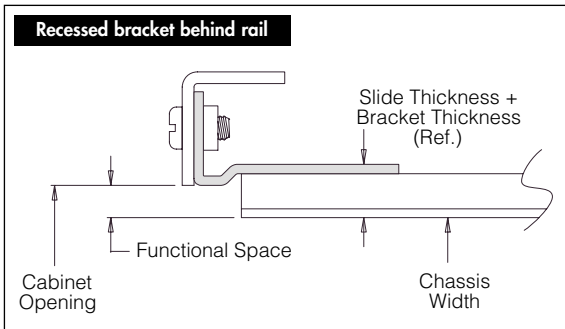
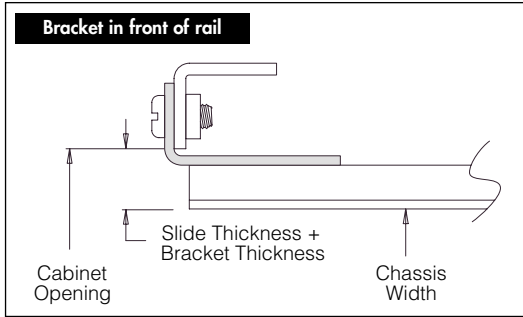
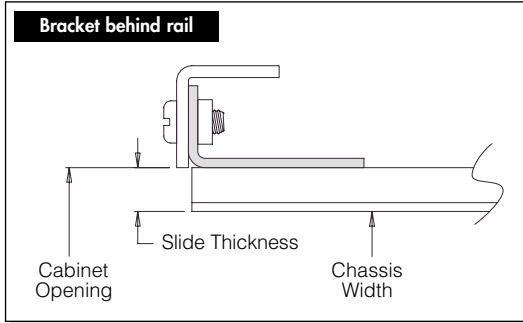

The drawings at left show several mounting configurations from an overhead perspective. This viewpoint demonstrates how chassis widths are calculated; slide thickness evaluated, and installations of brackets verified.

- Bracket behind rail
- Bracket in front of rail
- Recessed bracket behind rail
- Bracket behind flush-return rail
- Recessed slide and bracket behind rail

If some component dimensions are known, the space available for the remaining components may be determined:

IF KNOWN	CAN BE DETERMINED
Slide width and cabinet opening	Chassis width
Chassis width and cabinet opening	Slide width/ bracket thickness
Cabinet opening	Chassis width and slide width

SLIDE POSITION ON THE CHASSIS

There are a number of factors used to determine the optimal slide-to-chassis mounting position:

- The internal components (venting, fans, plugs, screws, etc.) inside the chassis must be taken into account when establishing slide mounting position.
- The chassis center of gravity dictates location. The slide should be closely associated with the center of gravity to ensure chassis stability and slide performance.
- The chassis manufacturer may have a pre-designated mounting location.

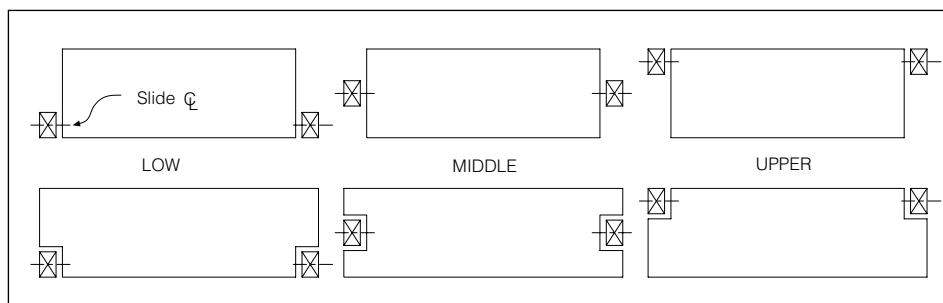

EIA cabinet pitch

- Consider the overall U height by using the bottom of the chassis as a reference and including the front panel or bezel which may have a greater height than the actual chassis.
- Make sure the slide/bracket location aligns with EIA cabinet pattern.
- Slide height should not exceed specific unit height.

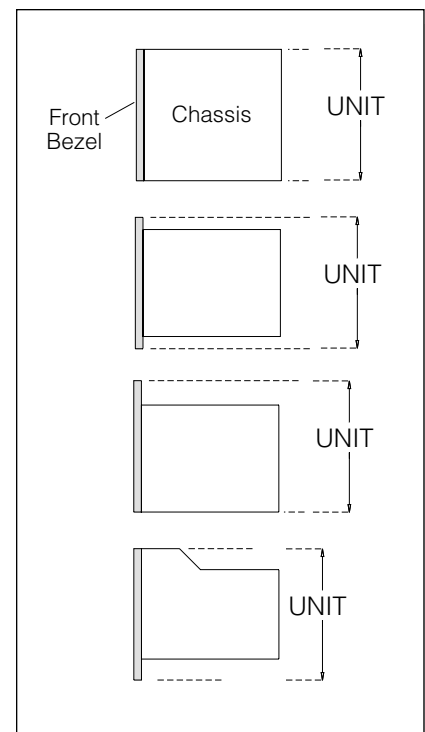
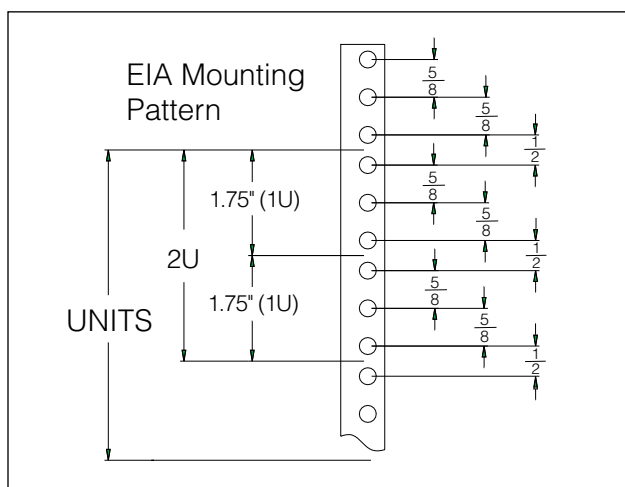

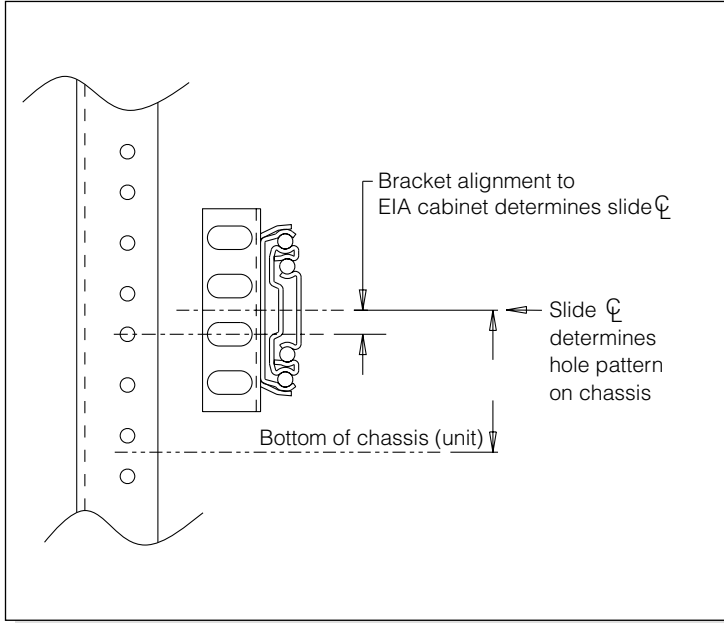

In other situations, one element of the slide installation is known and this determines slide positioning.

- Bracket alignment to EIA cabinet determines the slide centerline (CL).
- EIA cabinet pitch pattern determines the slide centerline.
- Location of the slide centerline determines the bracket alignment to EIA pattern on the cabinet.
- Slide centerline determines hole pattern on chassis.

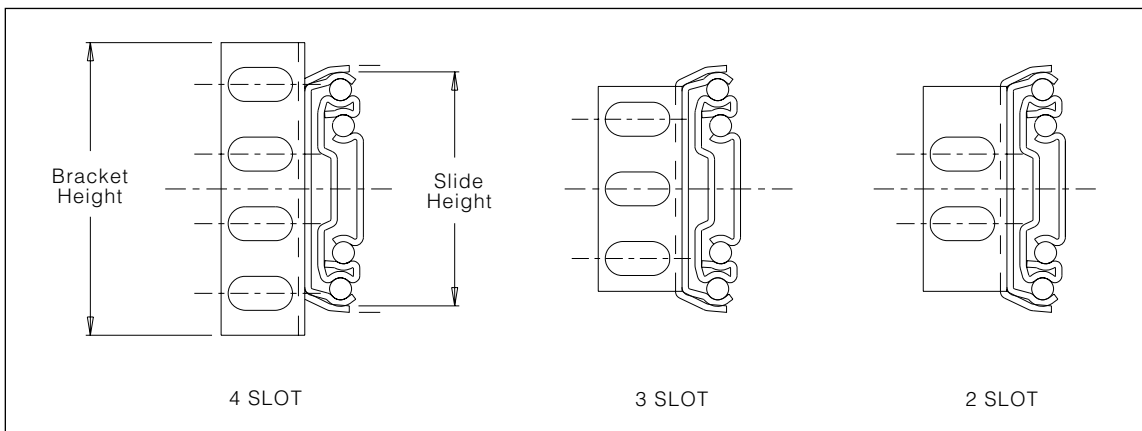

LOCATING/TRANSFERRING SLIDE HOLE PATTERN TO CHASSIS

The following illustrations assume the chassis front panel contacts the cabinet structure. Slide bracket placement and use of hardware will determine exact dimensions.

Determining the hole pattern from slide to chassis is calculated when the slide is fully closed or when the chassis is in its final closed position. The use of hardware with or without washers plays an important role in determining the fully closed position of the chassis relative to the cabinet's front rails. If washers are used, be sure to include the washer thickness dimension in your overall distance when determining the first chassis hole location.

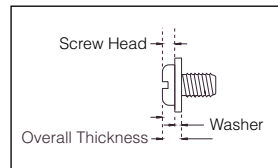

Follow the guideline that matches your planned installation to obtain first chassis hole dimension. Refer to Accuride data sheets to obtain remaining mounting hole locations.

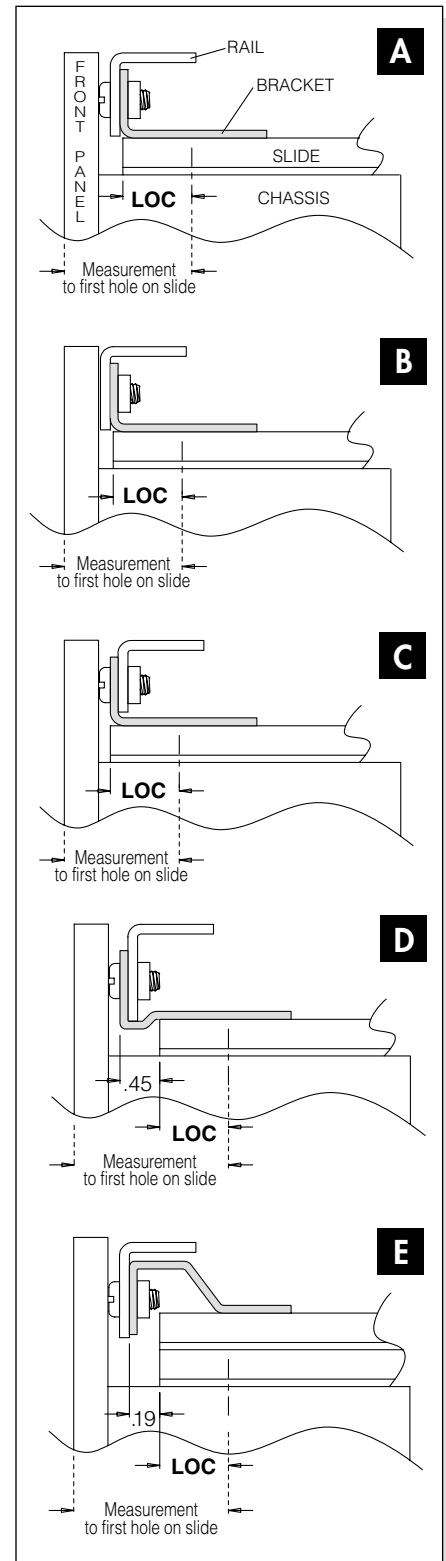
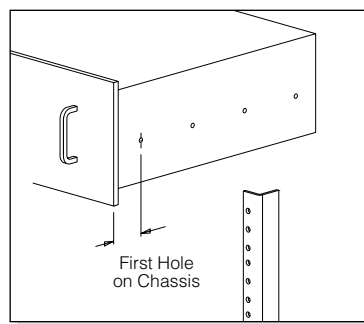
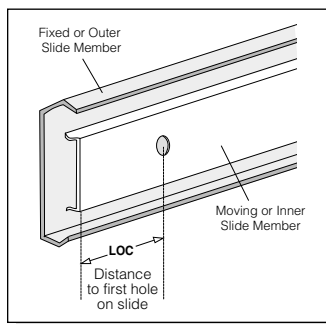

Bracket behind or in front of rail

Screw contacts back of chassis front panel (fig. A)

Front panel thickness + screw head thickness + cabinet rail thickness + distance to first slide mounting hole location

When using a flat head screw or other flush type (fig. B)

Front panel thickness + cabinet rail thickness + distance to first slide mounting hole location

Bracket in front of rail, slide and bracket aligned (fig. C)

Front panel thickness + screw head thickness + distance to first slide mounting hole location

Bracket in front or behind rail with recessed brackets

Recessed style bracket in front of rail (fig. D)

Front panel thickness + screw head thickness + .45" [11.43 mm] + distance to first slide mounting hole location

Screw head contacts front panel, bracket is recessed behind rail (fig. E)

Front panel thickness + screw head thickness + cabinet rail thickness + .19" [4.83 mm] + distance to first slide mounting hole location

COMPONENT ASSEMBLY

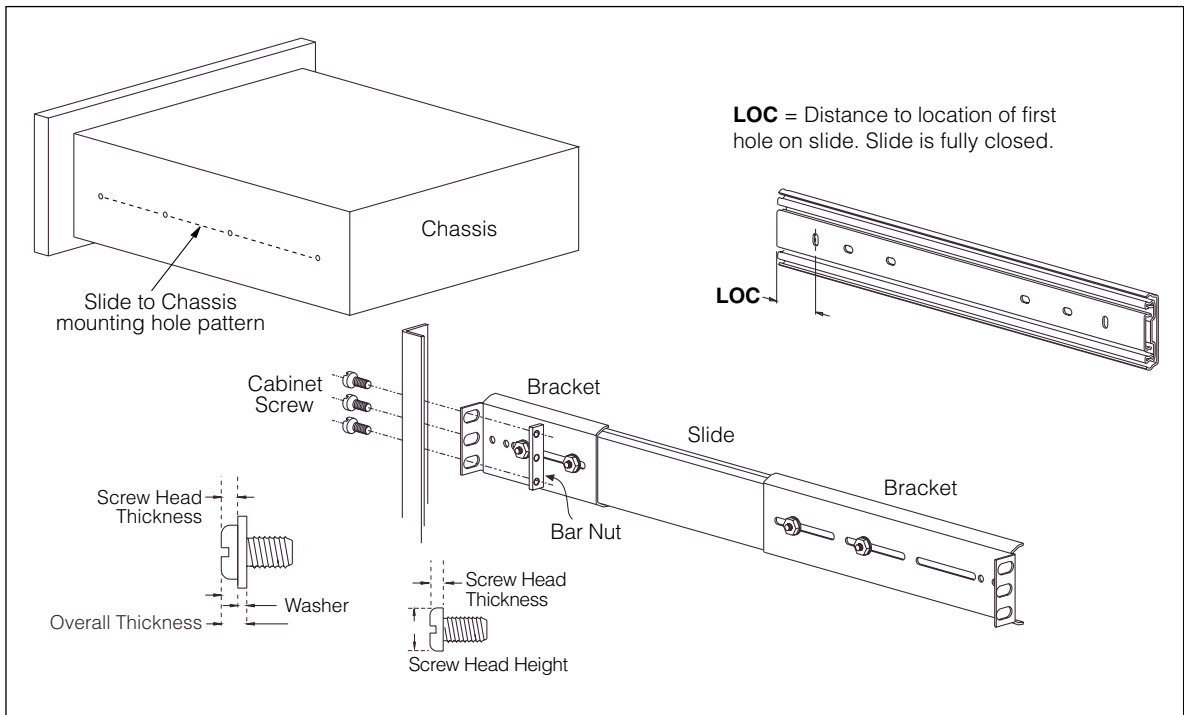

Mounting Accessories

Typical hardware for EIA packaging is shown. Due to differences in cabinet construction, not all hardware styles are shown.



BRACKET AND BAR NUT COMPARISONS

Accuride provides several mounting brackets and bar nut accessories to meet specific locations on the EIA cabinet. The use of 4-slot, 3-slot, and 2-slot mounting brackets and the companion bar nut selection provide a wide range of mounting possibilities. Consult Accuride data sheets for dimensions.

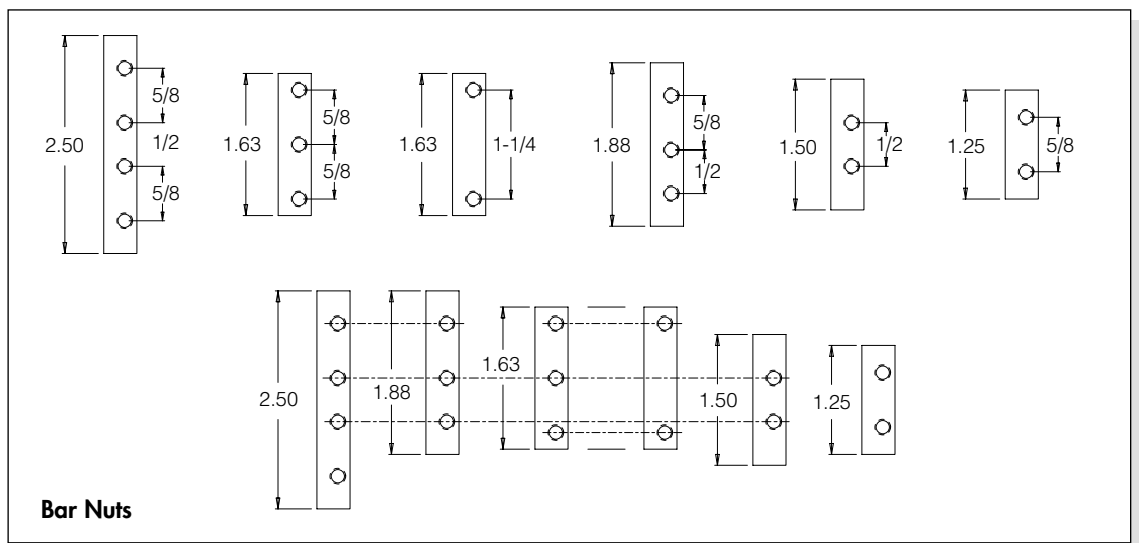
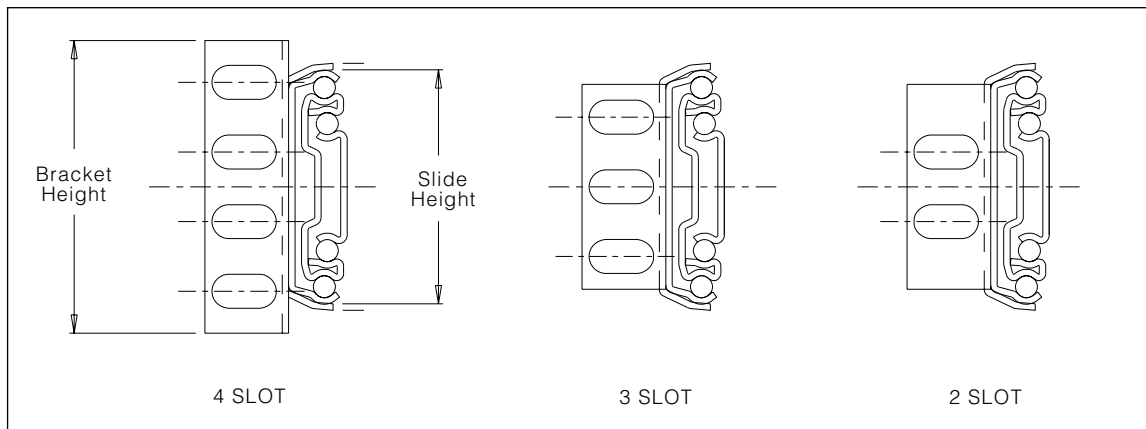
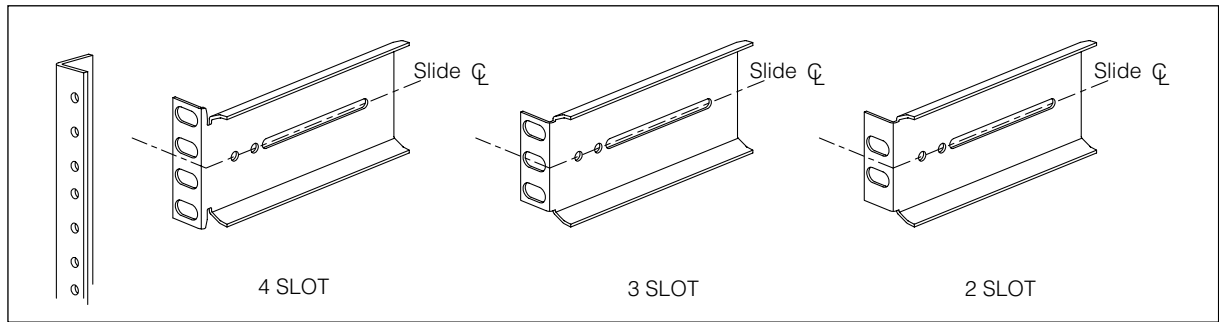

GLOSSARY:

Cabinet Width

The outside dimension (side to side) of a cabinet or enclosure.

Panel Width

The outer dimension of the front mounting rails which is greater than the clear opening between rails.

Cable Carrier

An accessory item to support and manage wiring behind a chassis when it is withdrawn or inserted into the cabinet.

Clear Opening

The innermost dimension between the front mounting rails.

Chassis Front Panel

Also known as panel width. Generally greater than the chassis width.

Depth

The front to rear dimensions of a cabinet or enclosure.

Chassis

A universal term for an electronics drawer; also known as the unit, drawer, module, device, stack equipment, system.

Front Panel or Bezel

The front facade of the chassis.

Front Panel Thickness

Distance from front of cabinet rail to front end of chassis.

Cabinet Rail Upright

Also known as mounting rail, column, strut, upright.

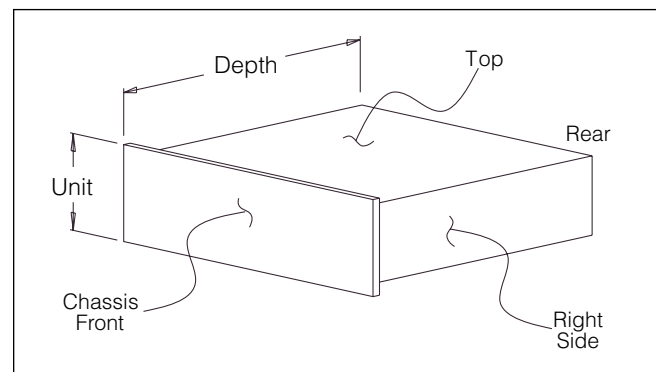
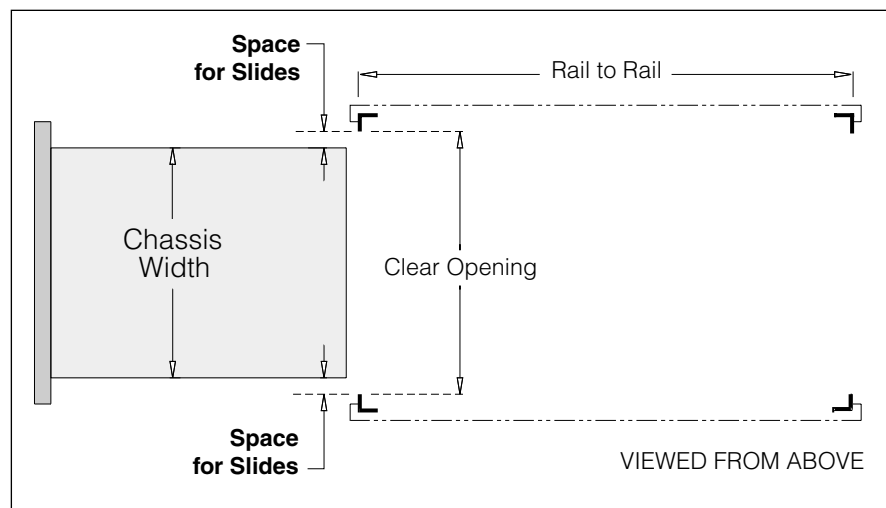
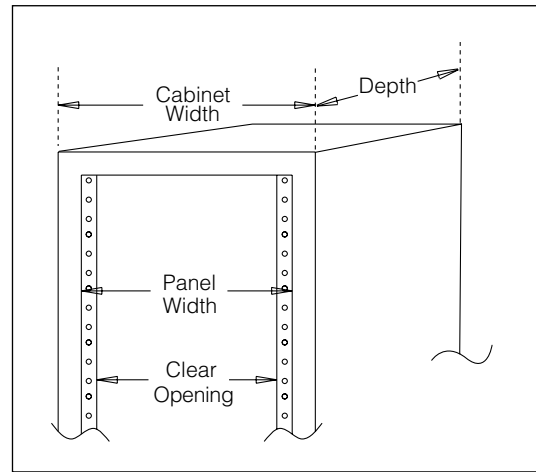

GLOSSARY:

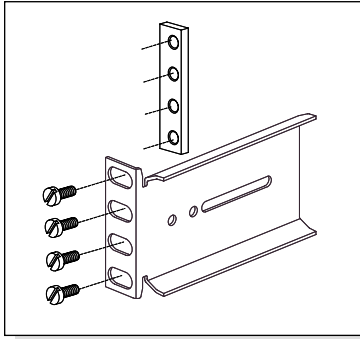

Cabinet Mounting Screws

Electronic hardware that attaches the slide brackets to the rails.

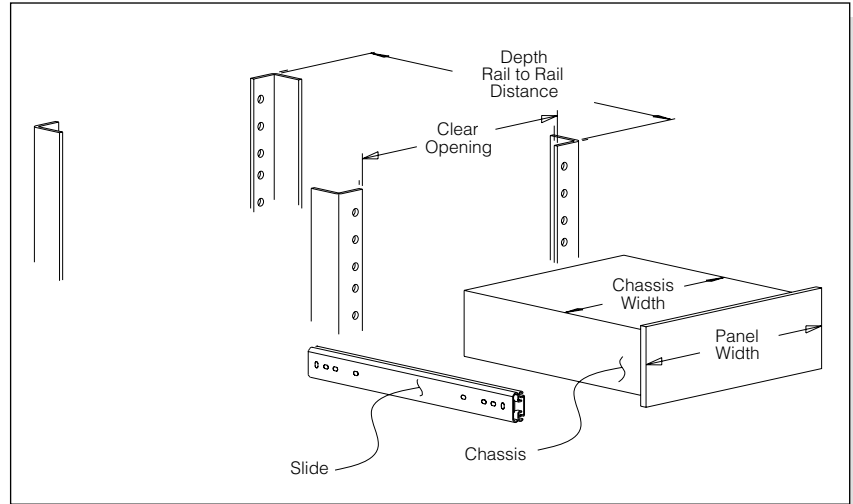

Slide

Sliding mechanism that serves as link between the enclosure and chassis. Also known as rail, glide, track, runner, chassis member, suspension.

Slide Mounting Bracket

Attachment device between the slide and cabinet.

Bar Nut

Threaded accessory used in place of hex nuts and washers.

Loc

The distance to the first mounting hole available on the moving or inner slide member.

☒ – The slide centerline

U (unit)

Incremental measure of 1.75" [44.45 mm].

Universal Cabinet Pattern

Mounting holes on cabinet rails in a repetitive series as follows: 1/2", 5/8", 5/8", 1/2", 5/8", 5/8", [12.7, 15.8, 15.8, 12.7, 15.8, 15.8 mm]

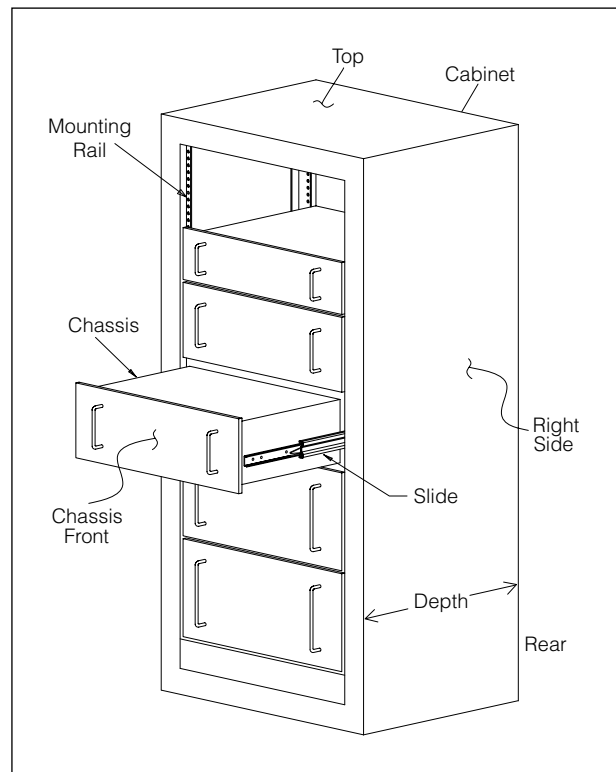



ACCURIDE LOCATIONS

North America

Accuride International
Headquarters
12311 Shoemaker Avenue
Santa Fe Springs, CA 90670
Telephone: (562) 903-0200
Fax: (562) 903-0208

Accuride
Calle Circuito Norte No. 12
Parque Industrial Nelson
Mexicali, B.C., C.P. 21395
Mexico

Europe

Accuride
Postfach 1464
Werner-Von Siemens-Strasse 16-18
65573 Diez/Lahn, Germany

Accuride
Liliput Road
Brackmills Industrial Estate
Northampton, NN4 7AS
United Kingdom

Far East

Accuride
Yusen Awajicho Building
1-4-1, Kanda-Awaji-cho, Chiyoda-ku,
Tokyo 101-0063, Japan