

APPLICATIONS: EIA rack-mount chassis, data processing, video and telecommunication racks, electro/mechanical devices, and photographic equipment. Use model 305A-LR whenever recessed mounting and positive lock-out is required. **This product is covered by U.S. and various foreign patents issued and/or pending.**

Lock-Out With Front Disconnect Over Travel, Medium Duty Slide Up to 140 lb. [64 kg.] Capacity**

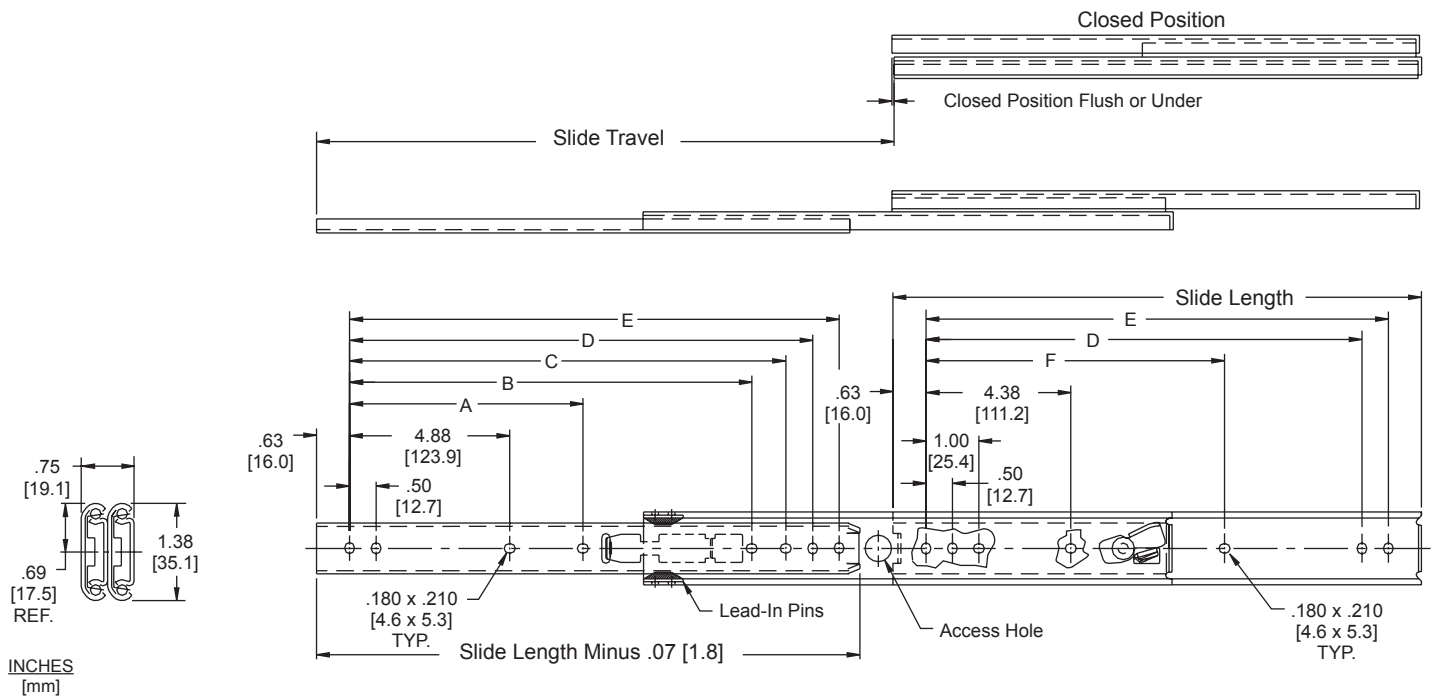

Finish Bright electro-zinc (C) or black zinc † (CB) finish available

Sidespace .38" (moving member) +.030/-.000 [9.5 mm (moving member) [+ .75/- .00]]

Length 12"–28" [302 mm–711 mm]

Mounting Side, bracket or hard mounting

Travel Slide length plus .88" [22.2 mm]

Hardware #8 pan head screw

Height 1.38" [35.1 mm]

Features Positive lock-out with front disconnect

Load 140 lbs.* [64 kg.] per pair

Part Number	Slide Length	Slide Travel	Load Rating lbs/[kg] pair	A	B	C	D	E	F
305-A12-LR	12.00 [305]	12.88 [327]	140 [64]				10.25 [260.4]	10.75 [273.1]	
305-A14-LR	14.00 [356]	14.88 [378]	132 [60]			11.75 [298.5]	12.25 [311.2]	12.75 [323.9]	
305-A16-LR	16.00 [406]	16.88 [429]	125 [57]			13.75 [349.3]	14.25 [362.0]	14.75 [374.7]	9.87 [250.8]
305-A18-LR	18.00 [457]	18.88 [480]	116 [53]	8.37 [212.7]		15.75 [400.1]	16.25 [412.8]	16.75 [425.5]	11.87 [301.6]
305-A20-LR	20.00 [508]	20.88 [530]	107 [49]	9.37 [238.1]	14.37 [365.1]	17.75 [450.9]	18.25 [463.6]	18.75 [476.3]	13.87 [352.4]
305-A22-LR	22.00 [559]	22.88 [581]	100 [45]	10.37 [263.5]	16.37 [415.9]	19.75 [501.7]	20.25 [514.4]	20.75 [527.1]	15.87 [403.2]
305-A24-LR	24.00 [610]	24.88 [632]	93 [42]	11.37 [288.9]	18.37 [466.7]	21.75 [552.5]	22.25 [565.2]	22.75 [577.9]	17.87 [454.0]
305-A26-LR	26.00 [660]	26.88 [683]	86 [39]	12.37 [314.3]	20.37 [517.5]	23.75 [603.3]	24.25 [616.0]	24.75 [628.7]	19.87 [504.8]
305-A28-LR	28.00 [711]	28.88 [734]	80 [36]	13.37 [339.7]	22.37 [568.3]	25.75 [654.1]	26.25 [666.8]	26.75 [679.5]	21.87 [555.6]

† Minimum order quantities may apply.

* Load rating based on a 12" slide on a 16" wide drawer cycled 10,000 times.

Installation Instructions

Instructions to Bracket Mount

1. To ensure proper operation of the slides, make certain all mounting screws are inserted so that the screw heads are inside the slides. (No washers on the inside of the slides.)
2. Separate slide members by depressing the lock release lever.
3. Using mounting kits and brackets, mount brackets to slide cabinet member (largest) using #8-32 screws. See Figure 1. For adjustment purposes screw the rear brackets on loosely.
4. Install slides into EIA rack with (customer supplied) #10-32 screws and secure with bar nuts. Rear adjustment is possible by aligning the back bracket. Do not tighten screws until final adjustment is made.
5. Mount chassis members 1/8" from the front edge of the chassis making sure both slides are parallel.
6. With cabinet members in the closed position and ball retainers fully forward, install chassis by engaging the slide members and close completely. Check slide alignment by opening and closing the chassis. Any sign of binding indicates lateral stress or misalignment.
7. Adjust slide position until movement is smooth. Tighten all screws and if necessary use more screws to secure slides and complete installation.

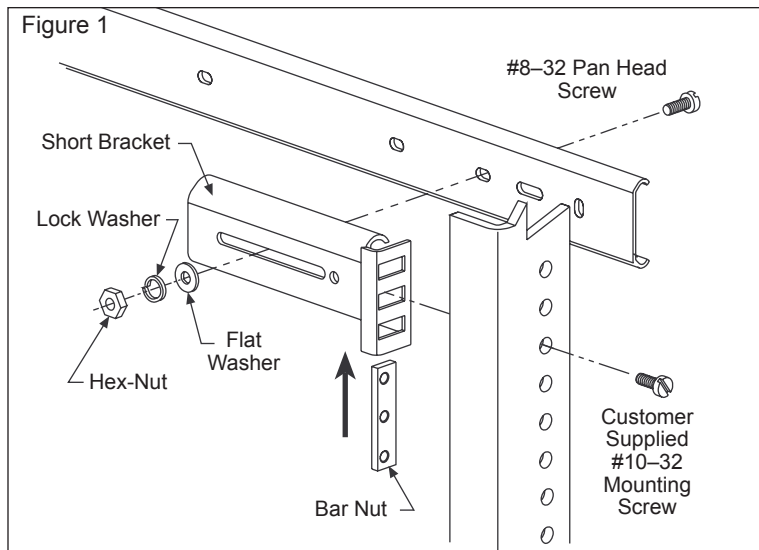

Instructions to Hard Mount

1. Follow steps 1 and 2 of "Bracket Mount" instructions.
2. With slides fully extended, install slide cabinet members (largest) into cabinet using # 8 pan head screws through uncovered mounting slots. Move intermediate members to allow access to remaining slots. Be sure slides are parallel.
3. Mount chassis members. Access covered mounting holes by moving the intermediate members away from you. Leave all screws loose for future adjustment. Make sure slides are parallel.
4. Follow steps 6 and 7 of "Bracket Mount" instructions.

Packaging

Distributor (D) Pack: All lengths are packaged 5 pair per box. Polybag includes one pair of slides packed with screws.

Bulk (P) Pack: Lengths 12"-18" 12 pair per box
Lengths 20"-28" 5 pair per box

Order optional bracket mounting hardware kit (part number 4180-0223-XE) separately.

Slide Ordering Instructions

Complete your slide order for model 305-ALR by specifying the following:

10 Pair C 305 -A18-LR D

Total Slides Required	_____
Slide Finish	_____
Slide Model	_____
Slide Length	_____
Optional Polybag Packaging (includes mounting screws)	_____

Optional Hardware Kits Ordered Separately

Kit contains mounting brackets and mounting hardware. Order 1 kit per pair of slides.

10 Each 4180-0223-XE

Total Bracket Kit Required	_____
Optional Bracket Kit Part Number	_____

Bracket kit includes 4 short brackets and a hardware kit which includes screws, hex-nuts, washers, and bar nuts to mount one pair of slides.

Specifications

Slide members: Cold rolled steel
Ball retainers: Cold rolled steel
Ball bearings: Carburized steel

NOTE: Specifications, materials, prices, terms, and delivery are subject to change without notice.

Accuride

ACCURIDE INTERNATIONAL INC.

12311 Shoemaker Avenue
Santa Fe Springs, CA 90670

TEL (562) 903-0200
FAX (562) 903-0208
www accuride.com

Manufacturing, Engineering, and Sales
United States • Germany • Japan • Mexico • United Kingdom • China