

APPLICATIONS: EIA rack-mount chassis, cash drawers, industrial workstations, medical emergency carts, and vending machines. Use model 3308 whenever a medium duty, over travel slide with lock in and out is required.

Medium Duty, Lever Disconnect
Over Travel, Lock-In, Lock-Out
Up to 150 lb. Capacity
Up to [68 kg.] Capacity

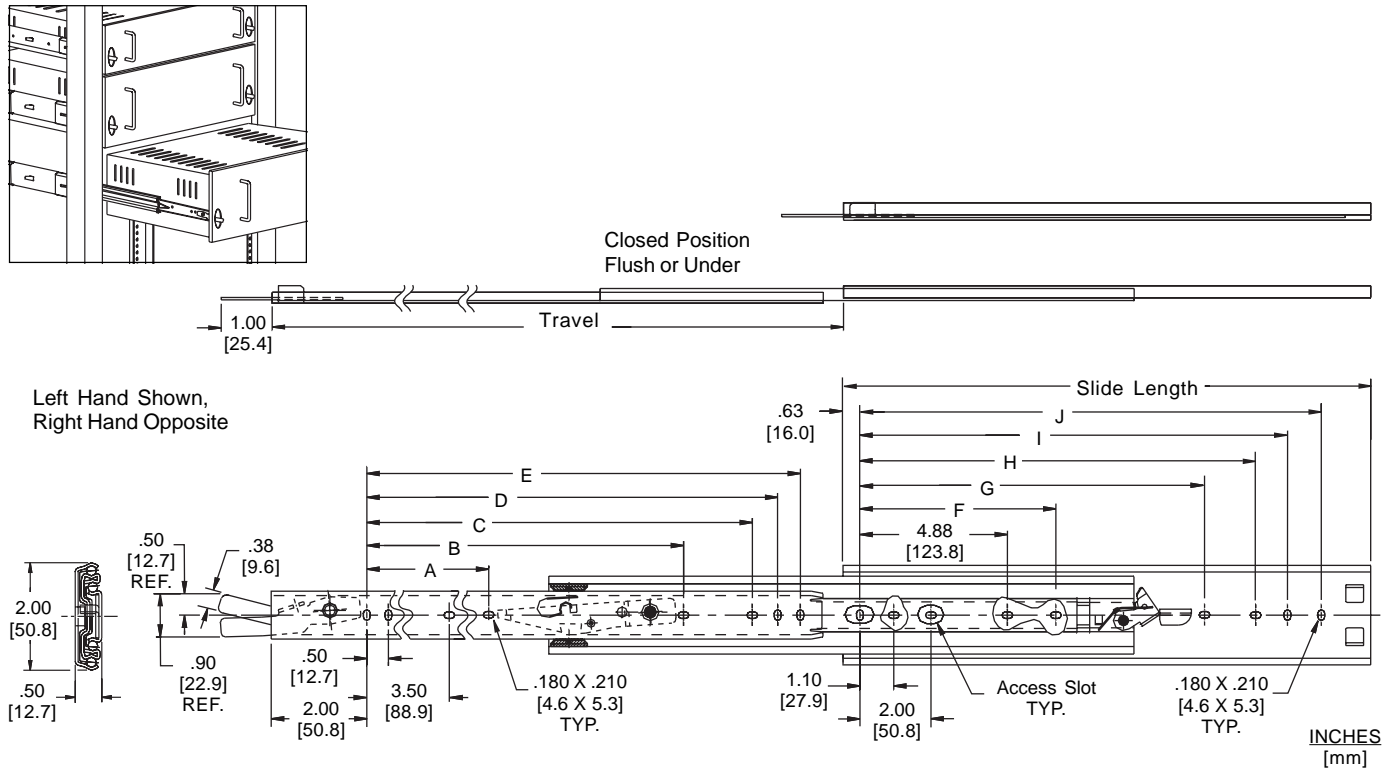

- | | |
|---|---|
| Finish Bright electro-zinc (C) plating only | Mounting Bracket or hard mounting |
| Length 12" - 28" [305mm - 711mm] | Movement Steel ball bearing |
| Travel Slide length plus 1" [25.4mm] | Hardware #8 pan head screw |
| Height 2.00" [50.8mm] | Disconnect Lever disconnect |
| Load See Chart* | Features Lock in holds chassis closed. Lock out holds chassis fully open. Lead-in pins guide chassis during reinsertion. |
| Side Space .50" +.015 / -.000 [12.7mm +0.4 / -0.0] | |

* Load rating based on a 16" wide drawer cycled 10,000 times.

Part Number	Slide Length	Slide Travel	* Load Rating lb. [kg.] per pair	A	B	C	D	E	F	G	H	I	J
3308-12	12.00 [305]	13.00 [330]	150 [68.2]			7.88 [200.1]	8.38 [212.8]	8.88 [225.5]			8.25 [209.5]	9.25 [234.9]	10.25 [260.3]
3308-14	14.00 [356]	15.00 [381]	148 [67.3]			9.88 [250.9]	10.38 [263.6]	10.88 [276.3]			10.25 [260.3]	11.25 [285.7]	12.25 [311.1]
3308-16	16.00 [406]	17.00 [432]	147 [66.8]			11.88 [301.7]	12.38 [314.4]	12.88 [327.1]			12.25 [311.1]	13.25 [336.5]	14.25 [361.9]
3308-18	18.00 [457]	19.00 [483]	146 [66.4]	5.63 [143.0]	11.00 [279.4]	13.88 [352.5]	14.38 [365.2]	14.88 [377.9]	7.00 [177.8]	12.38 [314.4]	14.25 [361.9]	15.25 [387.3]	16.25 [412.7]
3308-20	20.00 [508]	21.00 [533]	145 [65.9]	6.63 [168.4]	13.00 [330.2]	15.88 [403.3]	16.38 [416.0]	16.88 [428.7]	8.00 [203.2]	14.38 [365.2]	16.25 [412.7]	17.25 [438.1]	18.25 [463.5]
3308-22	22.00 [559]	23.00 [584]	140 [63.6]	7.63 [193.8]	15.00 [381.0]	17.88 [454.1]	18.38 [466.8]	18.88 [479.5]	9.00 [228.6]	16.38 [416.0]	18.25 [463.5]	19.25 [488.9]	20.25 [514.3]
3308-24	24.00 [610]	25.00 [635]	135 [61.4]	8.63 [219.2]	17.00 [431.8]	19.88 [504.9]	20.38 [517.6]	20.88 [530.3]	10.00 [254.0]	18.38 [466.8]	20.25 [514.3]	21.25 [539.7]	22.25 [565.1]
3308-26	26.00 [660]	27.00 [686]	127 [57.7]	9.63 [244.6]	19.00 [482.6]	21.88 [555.7]	22.38 [568.4]	22.88 [581.1]	11.00 [279.4]	20.38 [517.6]	22.25 [565.1]	23.25 [590.5]	24.25 [615.9]
3308-28	28.00 [711]	29.00 [737]	120 [54.5]	10.63 [270.0]	21.00 [533.4]	23.88 [606.5]	24.38 [619.2]	24.88 [631.9]	12.00 [304.8]	22.38 [568.4]	24.25 [615.9]	25.25 [641.3]	26.25 [666.7]

Installation Instructions

Instruction to Bracket Mount

- To ensure proper operation of the slides, ensure that all bracket mounting screws (#8-32) are inserted so that the screw heads are inside the slides. (No washers on the inside of the slides.)
- Separate slide members by actuating the disconnect lever. NOTE: Slides are handed.
- Using mounting kits and brackets, mount brackets to slide outer members (largest). For adjustment purposes, screw the back brackets on loosely.
- Install slides into EIA rack with #10 x 32 screws (customer supplied) and secure with bar nuts. Rear adjustment is possible by aligning the back bracket. Do not tighten screws until final adjustment is made.
- Mount slide drawer members (smallest) to the chassis. Position slides 1/8" [3.2mm] from the front edge of the chassis making sure both slides are parallel. Lock-in latch will extend through drawer front cut-out. Ensure right hand and left hand slide members are mounted to mate with correct hand slide.
- With cabinet members in the closed position and retainers fully forward, install chassis by engaging the slide members and close completely. Check slide alignment by opening and closing the chassis. Any sign of binding indicates lateral stress or misalignment.
- Adjust slide position until movement is smooth. Tighten all screws and if necessary, use more screws to secure slides and complete installation.

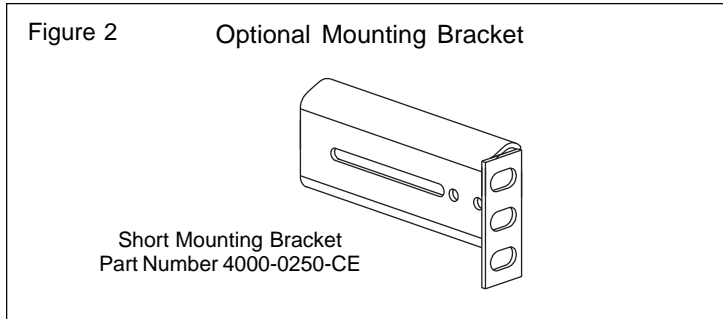
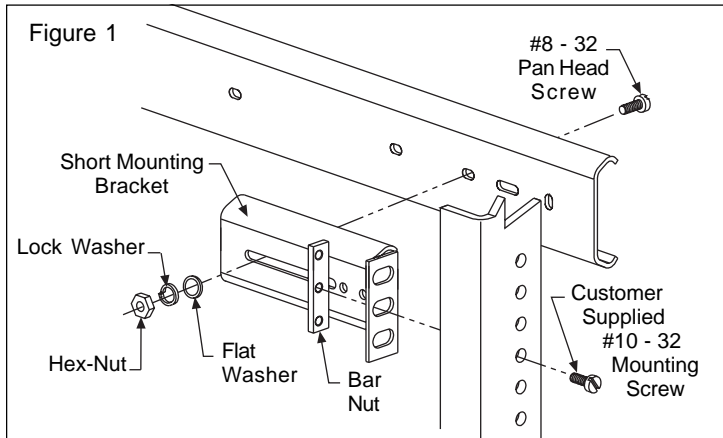

Instructions to Hard Mount

- Follow steps 1 and 2 of "Bracket Mount" instructions.
- With slides fully extended, install slide cabinet members (largest) into cabinet using #8 pan head screws. Ensure slides are parallel.
- Mount slide drawer members (smallest) to the chassis. Leave all screws loose for future adjustment. Ensure slides are parallel and handed members mated properly.
- Follow steps 6 and 7 of "Bracket Mount" instructions.

Copyright © 2002 Accuride International Inc. Printed in U.S.A. 3700-1070(9423)-MK563-R2-0402

Ordering Procedure

Complete your slide order for model 3308 by specifying the following:

Total Slides Required _____ 10 pair _____ C 3308 -18 D
 Slide Finish _____
 Slide Model _____
 Slide Length _____
 Optional Polybag Packing _____

Optional Mounting Brackets

Optional mounting brackets are ordered as **kits** or **bulk**.

Each **kit** contains enough brackets and hardware to mount one pair of slides. Order kit part number 4180-0219-XE.

Total Kits Required _____ 10 each _____ 4180-0219-XE
 Kit Part Number _____

Bracket kit includes the following. See Figure 1.

- 4 short brackets (part number 4000-0250-CE)
 - 1 bracket hardware kit* (part number 4180-0230-XE)
- (*Kit contains screws, hex-nuts, washers, bar nuts.)

For **bulk**, order 4 each short brackets and 1 hardware kit per pair of slides required. See Figure 2.

Total Brackets Required _____ 20 each _____ 4000-0250-CE
 Bracket Part Number _____

Total Hardware Kits Required _____ 20 each _____ 4180-0230-XE
 Hardware Kit* Part Number _____
 (*Kit contains screws, hex-nuts, washers, bar nuts.)

Packaging

Distributor (D) Pack: Polybag contains one pair of slides and one slide mounting hardware kit. Brackets ordered separately.

Lengths 12" - 20" 10 pair per box
 Lengths 22" - 28" 5 pair per box

Bulk (P) Pack: Slides and optional mounting bracket kit are ordered and packaged separately.

Lengths 12" - 22" 10 pair per box
 Lengths 24" - 28" 7 pair per box

Specifications

Slide members and ball retainers: Cold rolled steel

Ball bearings: Carburized steel

Note: Specifications, materials, prices, terms, and delivery are subject to change without notice.

Accuride

ACCURIDE INTERNATIONAL INC.

12311 Shoemaker Avenue
 Santa Fe Springs, CA 90670
 TEL (562) 903-0200
 FAX (562) 903-0208
 www.accuride.com
 Manufacturing, Engineering, and Sales
 United States • Germany • Japan • Mexico • United Kingdom

Copyright © 2002 Accuride International Inc. Printed in U.S.A. 3700-9423(1070)-MK072-R2-0402