

APPLICATIONS: For use on electronic chassis, keyboards, fan trays, and other rack-mount applications. Accommodates chassis from 4U to 8U. **This product is covered by U.S. and various foreign patents issued and/or pending.**

Heavy Duty
Ball Bearing Movement
2.00" [50.8 mm] Over Travel
200 lb.** [90.8 kg.] Load Capacity

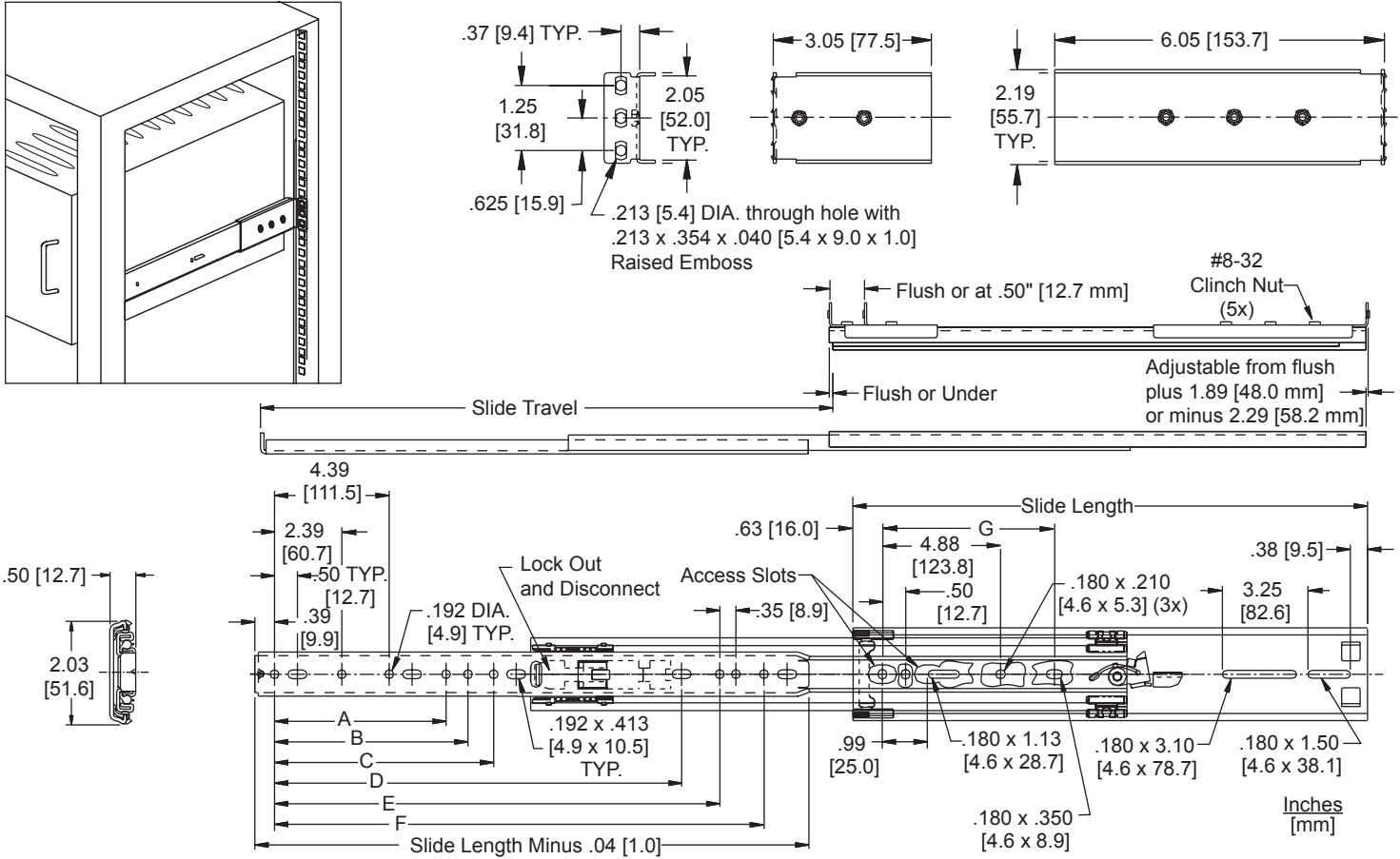

- Finish** Bright electro-zinc (C) •
- Lengths** 16"–30" [406 mm–762 mm]
- Height** 2.03" [51.6 mm]
- Load** See chart**
- Side Space** .50" ± 0.030 † * [12.7 mm ± 0.76 mm]
- Travel** 2.00" [50.8 mm] Over travel
- Mounting** *Chassis Member:*
#8 pan or binding head screw

Outer Member:
Adjustable front and rear mounting brackets, #10–32 machine screw

Features One-motion insertion™, unhandled, lock-out and disconnect, guide pins

† Brackets behind EIA rail with square holes.

** Load rating based on 16" chassis cycled 2,000 times

* No lateral adjustment with EIA rails using round or tapped holes.

• Clear zinc finish is RoHS compliant.

Part Number	Slide Length	Slide Travel	Load** Rating per Pair	A	B	C	D	E	F	G
3507-16	16.00 [406]	18.00 [457]	200 lb. [90.8 kg.]					6.40 [162.6]	13.25 [336.5]	6.05 [153.7]
3507-18	18.00 [457]	20.00 [508]	200 lb. [90.8 kg.]			6.49 [164.8]			15.25 [387.3]	7.04 [178.8]
3507-20	20.00 [508]	22.00 [559]	200 lb. [90.8 kg.]		6.78 [172.1]	8.00 [203.2]			17.25 [438.1]	8.02 [203.8]
3507-22	22.00 [559]	24.00 [610]	200 lb. [90.8 kg.]			8.39 [213.0]		16.03 [407.0]	19.25 [488.9]	9.01 [228.8]
3507-24	24.00 [610]	26.00 [660]	200 lb. [90.8 kg.]	10.00 [254.0]	10.78 [273.7]			18.03 [457.8]	21.25 [539.7]	9.99 [253.8]
3507-26	26.00 [660]	28.00 [711]	200 lb. [90.8 kg.]	5.53 [140.3]	9.15 [232.4]	10.60 [269.1]		20.03 [508.6]	23.25 [590.5]	10.98 [278.7]
3507-28	28.00 [711]	30.00 [762]	200 lb. [90.8 kg.]	7.53 [191.1]	11.15 [283.2]	12.00 [304.8]	20.71 [526.0]	22.03 [559.4]	25.25 [641.4]	11.96 [303.8]
3507-30	30.00 [762]	32.00 [813]	200 lb. [90.8 kg.]		9.53 [241.9]	12.60 [319.9]	20.75 [527.1]	24.03 [610.2]	27.25 [692.1]	12.94 [328.8]

Installation Instructions

- Slide chassis member (smallest) is removable. Separate slide members by pushing in the lock-in disconnect tab. Keep slide chassis member with original outer member.
- Slide has front and rear adjustable EIA brackets. Attach front brackets to outer slide member using #8-32 machine screws by aligning access slots in intermediate member with threaded inserts in bracket. Front brackets can be mounted flush or 1/2" [12.7 mm] back from front of slide based on user needs.
- Establish distance from front cabinet rail to rear cabinet rail and attach rear brackets to slide. **Do not** fully tighten rear bracket mounting screws until final adjustment is made.
- Insert removable locator pin into center hole of brackets.
- Slide will mount to various cabinet rails and at various locations on the chassis side. See illustrations at right.
- Place slide into desired position and fully extend against EIA rails. Locator pins will support slide and bar nut while attaching screws.
- Attach slide to EIA rail with #10-32 screws and fasten with bar nuts. Once screws are secure, remove locator pins. **Do not** fully tighten screws until final adjustment is made.
- Mount slide chassis member (smallest) to the chassis.
- With cabinet member in the open or closed position, bring ball retainer fully forward. Install chassis by engaging the slide members and close completely. Check slide alignment by opening and closing the chassis. Any sign of binding indicates lateral stress or misalignment.
- Adjust slide position until movement is smooth. Tighten all screws and complete installation.

NOTE: To remove chassis, depress the lock-in/disconnect tab.

Slide Ordering Instructions

Complete your order for Accuride Model 3507 by specifying the following. For example:

5 Pair C 3507 -18 D

Required Slides _____
 Slide Finish _____
 Slide Model _____
 Slide Length _____
 Optional Polybag Packaging _____

Optional Mounting Bracket Kit

Optional mounting bracket kit, part number 4180-0480-XE, includes (2) front brackets, (2) rear brackets, (4) bar nuts, (4) locator pins, (8) #8-32 bracket to slide machine screws, and (8) #10-32 bracket to rail machine screws in a polybag. Kits are ordered separately. One kit needed per pair of slides.

Packaging

Bulk (P) Pack:	Lengths 16"-20"	10 pair per box
	Lengths 22"-24"	8 pair per box
	Lengths 26"-28"	7 pair per box
	Length 30"	6 pair per box

Distributor (D) Pack: Polybag contains 1 pair of slides, 2 front brackets, 2 rear brackets, 1 bracket-to-slide mounting hardware kit, and technical sheet. All lengths are packaged 5 pair per box.

Specifications

Slide members and component parts: Cold rolled steel
 Ball bearings: Carburized steel

Clear zinc finish is RoHS compliant.

NOTE: Specifications, materials, prices, terms, and delivery are subject to change without notice.

For the most current technical information visit www accuride.com

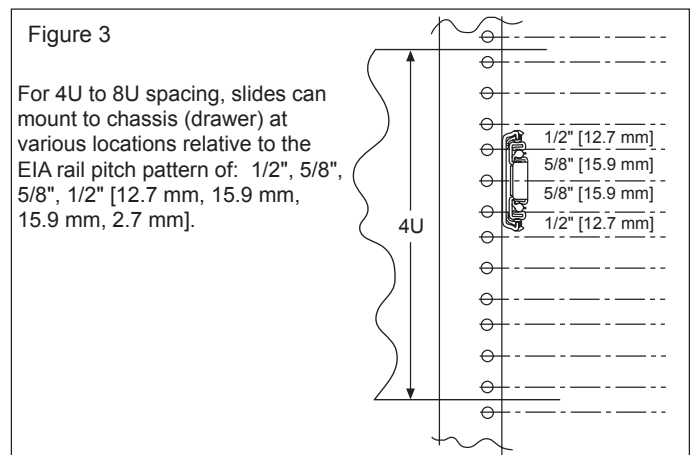
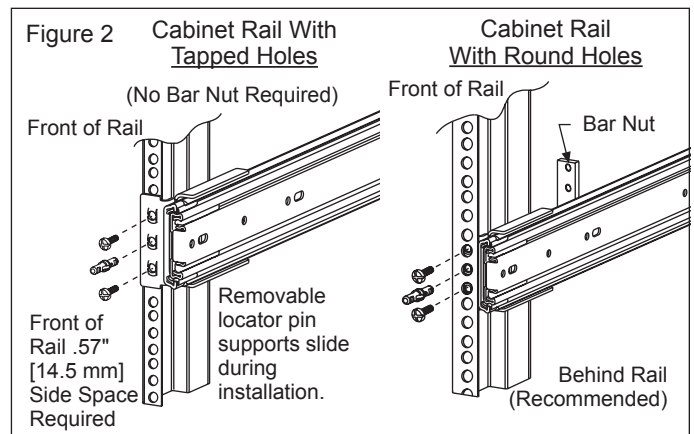
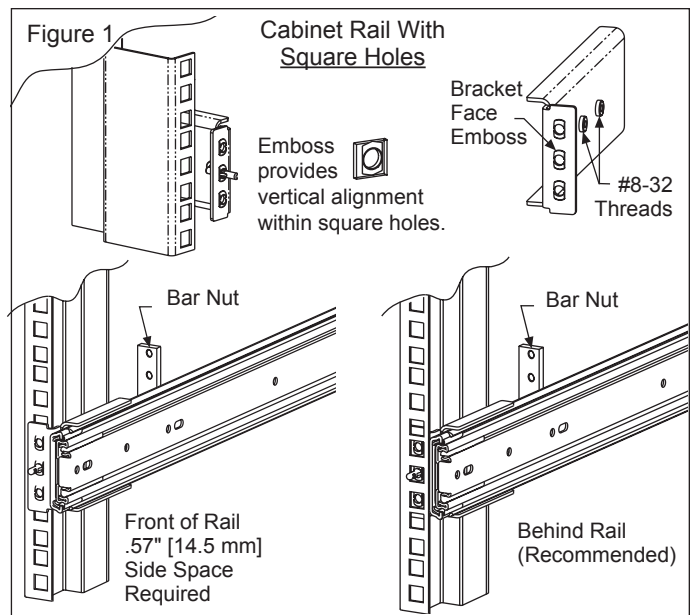

Accuride

ACCURIDE INTERNATIONAL INC.

12311 Shoemaker Avenue
 Santa Fe Springs, CA 90670

TEL (562) 903-0200
 FAX (562) 903-0208
www accuride.com

Manufacturing, Engineering, and Sales
 United States • Germany • Japan • Mexico • United Kingdom • China

Copyright © 2009 Accuride International Inc. 3700-9462(1100)-MK096-R4-0309