

APPLICATIONS: Industrial work stations, heavy duty machine tools and mechanical devices. Use model 3607 whenever a heavy duty slide with positive lock-out is required.

Lock-Out with Front Disconnect
 Three Member, Full Extension
 Heavy Duty Slide
 Up to 273 lb. (124 kg.) Capacity

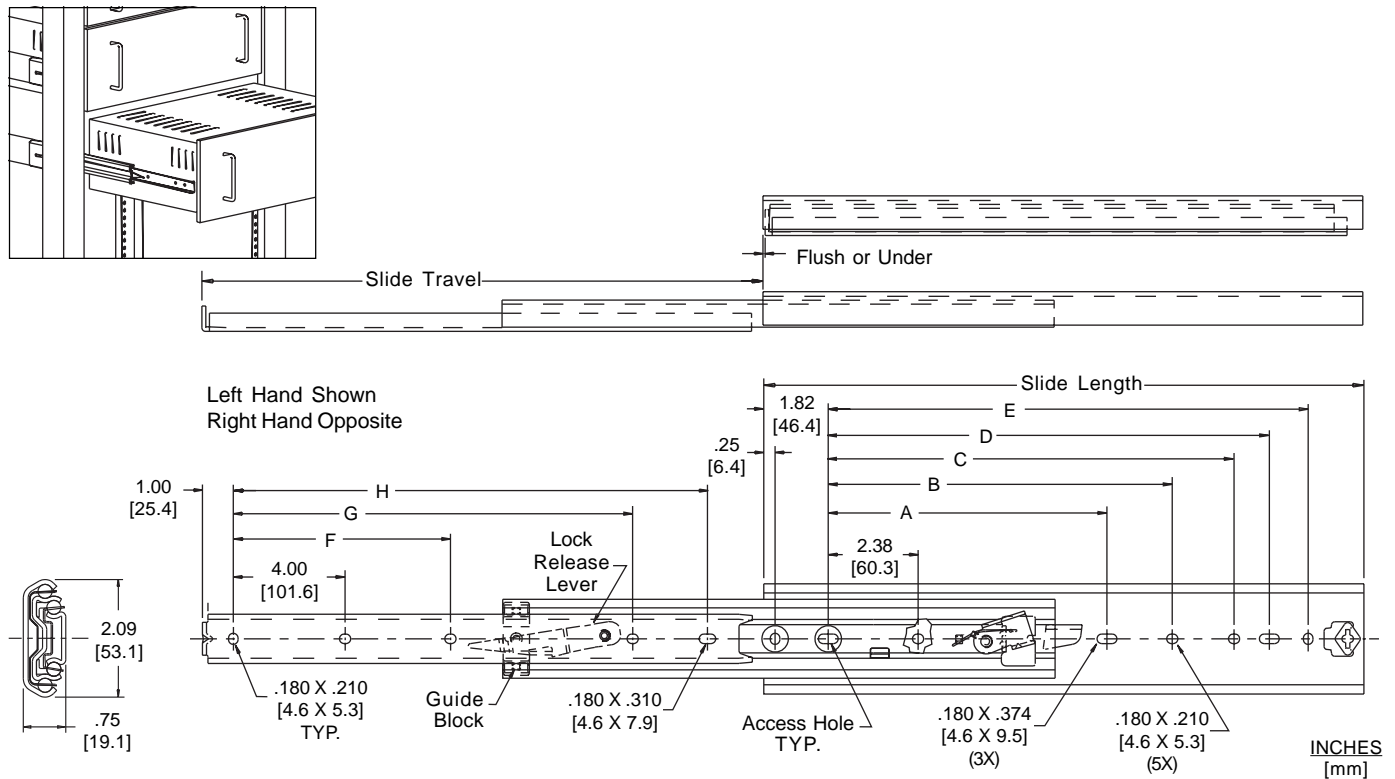

Finish Bright electro-zinc (C) plating

Length 12" to 28" [305mm to 711mm]

Height 2.09" [53.1mm]

Load See chart*

Side space .75" + .030/ - .000 [19.1mm + .76/ - .00]

Travel Full travel

Mounting Side, bracket, or hard mounting

Hardware #8 pan head screws

Movement Steel ball bearings

Features Positive lock-out and disconnect, handed slide

Part Number	Slide Length	Slide Travel	Load Rating * lbs [kg]	A	B	C	D	E	F	G	H
C3607-12	12.00 [305]	12.00 [305]	273 [124]		5.33 [135.4]	7.05 [179.1]	8.05 [204.5]	9.05 [229.9]			9.00 [228.6]
C3607-14	14.00 [356]	14.00 [356]	267 [121]		7.33 [186.2]	9.05 [229.9]	10.05 [255.3]	11.05 [280.7]			11.00 [279.4]
C3607-16	16.00 [406]	16.00 [406]	261 [119]		9.33 [237.0]	11.05 [280.7]	12.05 [306.1]	13.05 [331.5]		10.13 [257.3]	13.00 [330.2]
C3607-18	18.00 [457]	18.00 [457]	253 [115]		11.33 [287.8]	13.05 [331.5]	14.05 [356.9]	15.05 [382.3]		12.13 [308.1]	15.00 [381.0]
C3607-20	20.00 [508]	20.00 [508]	244 [111]	8.50 [215.9]	13.33 [338.6]	15.05 [382.3]	16.05 [407.7]	17.05 [433.1]	8.00 [203.2]	14.13 [358.9]	17.00 [431.8]
C3607-22	22.00 [559]	22.00 [559]	233 [106]	9.50 [241.3]	15.33 [389.4]	17.05 [433.1]	18.05 [458.5]	19.05 [483.9]	9.00 [228.6]	16.13 [409.7]	19.00 [482.6]
C3607-24	24.00 [610]	24.00 [610]	220 [100]	10.50 [266.7]	17.33 [440.2]	19.05 [483.9]	20.05 [509.3]	21.05 [534.7]	10.00 [254.0]	18.13 [460.5]	21.00 [533.4]
C3607-26	26.00 [660]	26.00 [660]	203 [92]	11.50 [292.1]	19.33 [491.0]	21.05 [534.7]	22.05 [560.1]	23.05 [585.5]	11.00 [279.4]	20.13 [511.3]	23.00 [584.2]
C3607-28	28.00 [711]	28.00 [711]	182 [83]	12.50 [317.5]	21.33 [541.8]	23.05 [585.5]	24.05 [610.9]	25.05 [636.3]	12.00 [304.8]	22.13 [562.1]	25.00 [635.0]

* Load rating based on slides mounted in a 16" wide drawer cycled 10,000 times.

Installation Instructions

Instructions to Bracket Mount

1. To ensure proper operation of the slides, make certain all mounting screws are inserted so the screw heads are inside the slides. (No washers on the inside of the slides.)
2. Separate slide members by pushing up on lock release lever. **Note:** Slides are handed. Ensure that left hand drawer members mate with left hand cabinet members, etc, to prevent damage upon re-connect.
3. Using mounting kits and brackets, mount brackets to slide cabinet members (largest). For adjustment purposes screw the rear brackets on loosely.
4. Install slides into EIA rack with (customer supplied) #10-32 screws and secure with bar nuts. Rear adjustment is possible by aligning the back bracket. Do not tighten screws until final adjustment is made.
5. Mount slide drawer members (smallest) to the chassis. Position slides 1/8" [3.2mm] from the front edge of the chassis making sure both slides are parallel.
6. With cabinet members in the closed position and ball retainers fully forward, install chassis by engaging the slide members and close completely. Check slide alignment by opening and closing the chassis. Any sign of binding indicated lateral stress or misalignment.
7. Adjust slide position until movement is smooth. Tighten all screws and if necessary, use more screws to secure slides and complete installation.

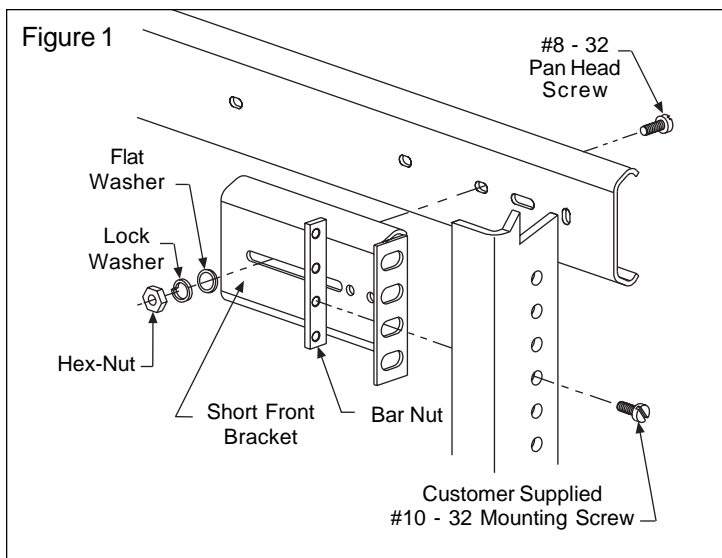

Instructions to Hard Mount

1. Follow steps 1 and 2 of "Bracket Mount" instructions.
2. With slides fully extended, install slide cabinet members (largest) into cabinet using #8 pan head screws. Be sure slides are parallel.
3. Mount slide drawer members (smallest) to chassis. Leave all screws loose for future adjustment. Make sure slides are parallel.
4. Follow steps 6 and 7 of "Bracket Mount" instructions.

Packaging

Distributor (D) Pack: All lengths are packaged 5 pair per box. Polybag includes one pair of slides packaged with screws.

Bulk Pack: Lengths 12" - 20" 14 each per box
Lengths 22" - 28" 10 each per box

Left and right hand slides packaged separately. Order optional bracket mounting hardware kit (part number 4180-0220-XE) separately.

Slide Ordering Instructions

Complete your slide order for Model 3600 by specifying the following:

Total Slides Required _____ 10 Pair _____ C 3607 -18 D
Slide Finish _____
Slide Model _____
Slide Length _____
Optional Polybag Packaging (includes mounting screws) _____

Optional Hardware Kits - Ordered Separately

Mounting bracket kits are ordered separate. Each kit contains enough brackets and hardware to mount one pair of slides. Order kit part number 4180-0220-XE.

Total Bracket Kits Required _____ 10 Each _____ 4180-0220-XE
Optional Bracket Kit Part Number _____

Bracket kit includes the following. See Figure 1.

- 2 short front brackets (part number 4000-0501-CE)
- 2 long rear brackets (part number 4000-0502-CE)
- 1 bracket hardware kit * (part number 4180-0232-XE)
- * (Kit contains screws, hex-nuts, washers, bar nuts.)

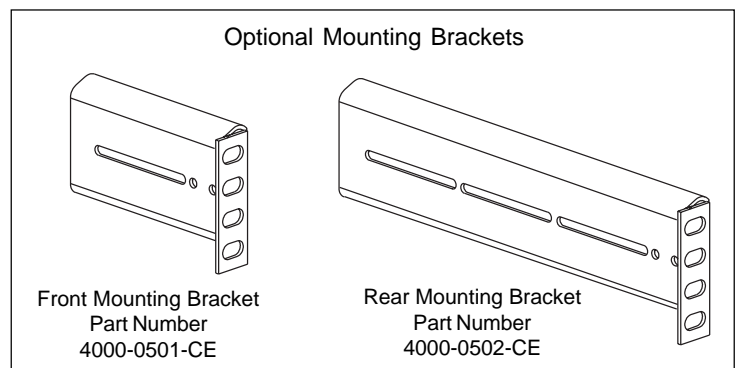

Specifications

Slide members and ball retainers: Cold rolled steel
Ball bearings: Carburized steel

Note: Specifications, materials, prices, terms, and delivery are subject to change without notice.

Accuride

ACCURIDE INTERNATIONAL INC.

12311 Shoemaker Avenue
Santa Fe Springs, CA 90670

TEL (562) 903-0200

FAX (562) 903-0208

www accuride.com

Manufacturing, Engineering, and Sales

United States • Germany • Japan • Mexico • United Kingdom