

PART NO.	DESCRIPTION
206-XUR/L	ASSEMBLY WITH STRIKER P/N 206-15
206-XR/L	ASSEMBLY WITHOUT STRIKER P/N 206-15

① NOTE:
RECOMMENDED INSTALL WITH
4 GRADE 8, 1/4 BOLTS

NO	CHANGE	ENG.NO.	DATE
	REVISED AND REDRAWN	EN 4575	2-5-93
1	ADDED: INSTALLATION NOTE, FMSS 206 STICKER	EN 5390	2-20-09

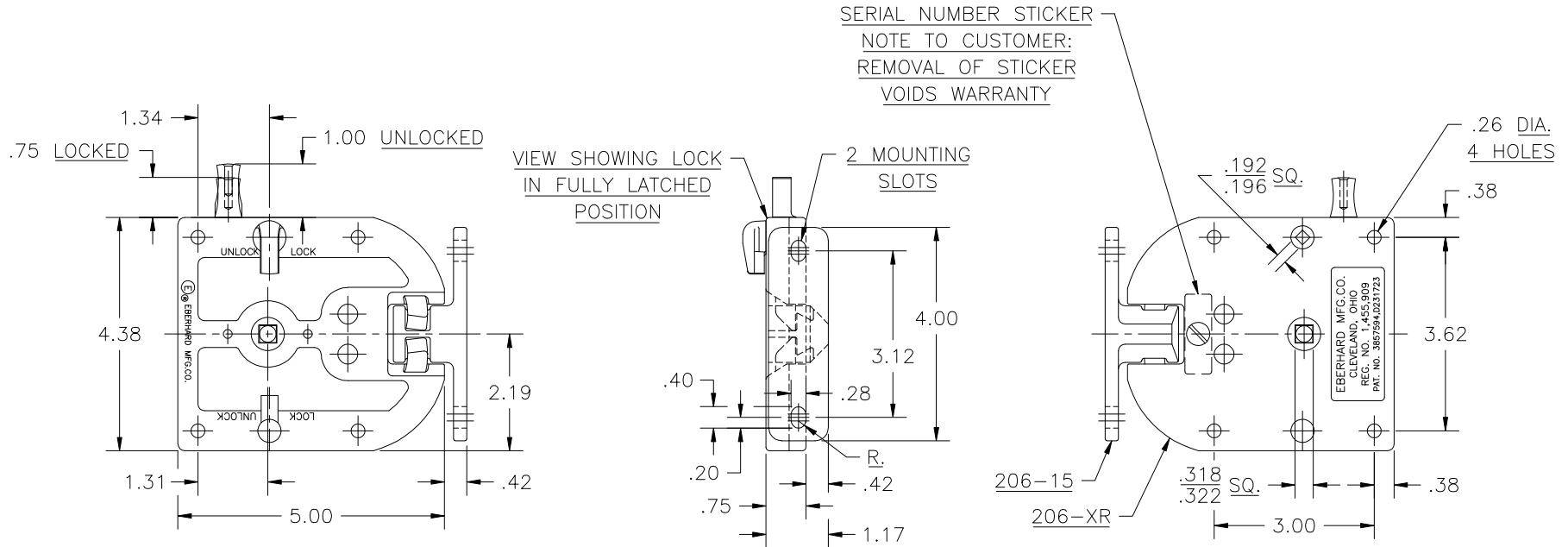

SERIAL NUMBER STICKER
NOTE TO CUSTOMER:
REMOVAL OF STICKER
VOIDS WARRANTY

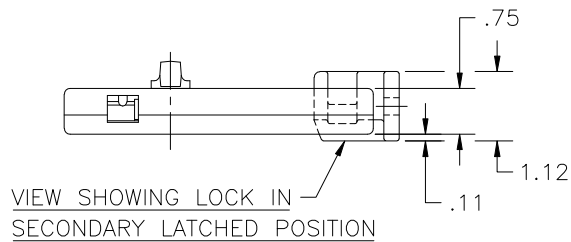

CUSTOMER PRINT
RIGHT HAND SHOWN
LEFT HAND OPPOSITE

EBERHARD MANUFACTURING CO. DIVISION OF THE EASTERN COMPANY CLEVELAND, OHIO 44136-6697	
NAME SLAM LOCK W/VERTICAL LOCKING BUTTON, INSIDE LOCKING KNOB & STRIKER	PART NUMBER 206-XUR/L

UNLESS OTHERWISE SPECIFIED TOLERANCES ARE AS FOLLOWS:	DATE 1-25-93
ANGLES: ±2'	DR. BY SAA
2 PLACE DEC.: ±.03	SCALE HALF
3 PLACE DEC.: ±.015	CHK. BY
ALL HOLES: ±.005	

SUPERSEDES DRAWING 206-XUR/L CHART DATED 10-3-90.