



# 64 Push-to-Close Latch

Pull-to-open · Paddle latch · Miniature

- Single hole installation
- Concealed mounting
- Plastic slide

## Material and Finish

Stainless steel passivated and brushed finish and glass reinforced nylon, black

## Performance Details

Max. working load:

90 N (20 lbf)

Operating temperature range:

-18°C (0°F) to 100°C (210°F)

Flammability rating: UL94-V0

## Installation Notes

Max. tightening torque on mounting screws: 0.9 N·m (8 in·lbf)

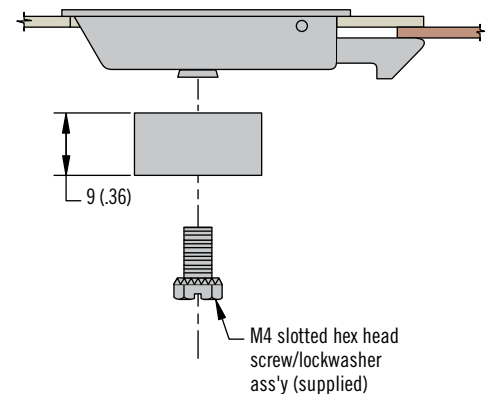
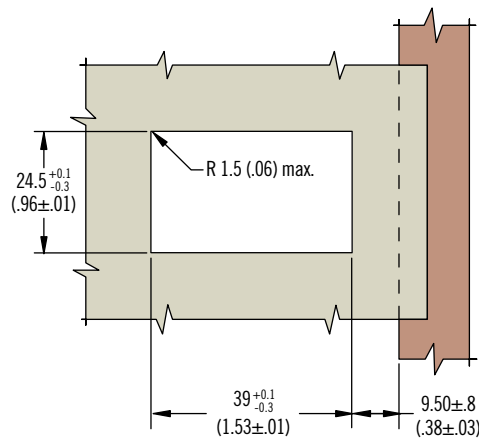
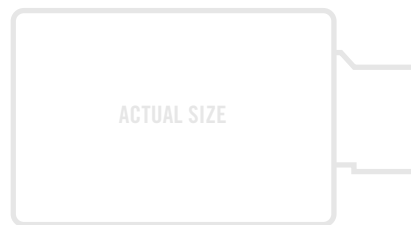
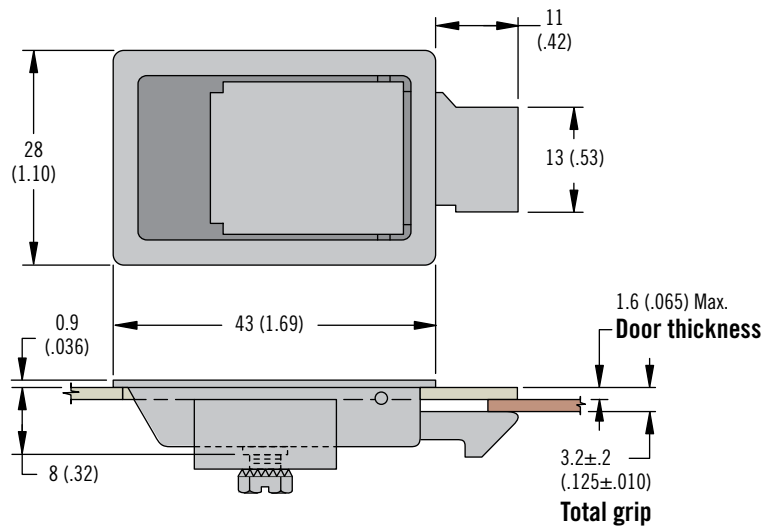

## Part Number

See table

## Part Number

64-01-10



[www.southco.com/64](http://www.southco.com/64)

Dimensions in millimeters (inch) unless otherwise stated

**southco**  
CONNECT · CREATE · INNOVATE

# 64 Push-to-Close Latch

Pull-to-open · Paddle latch · Small

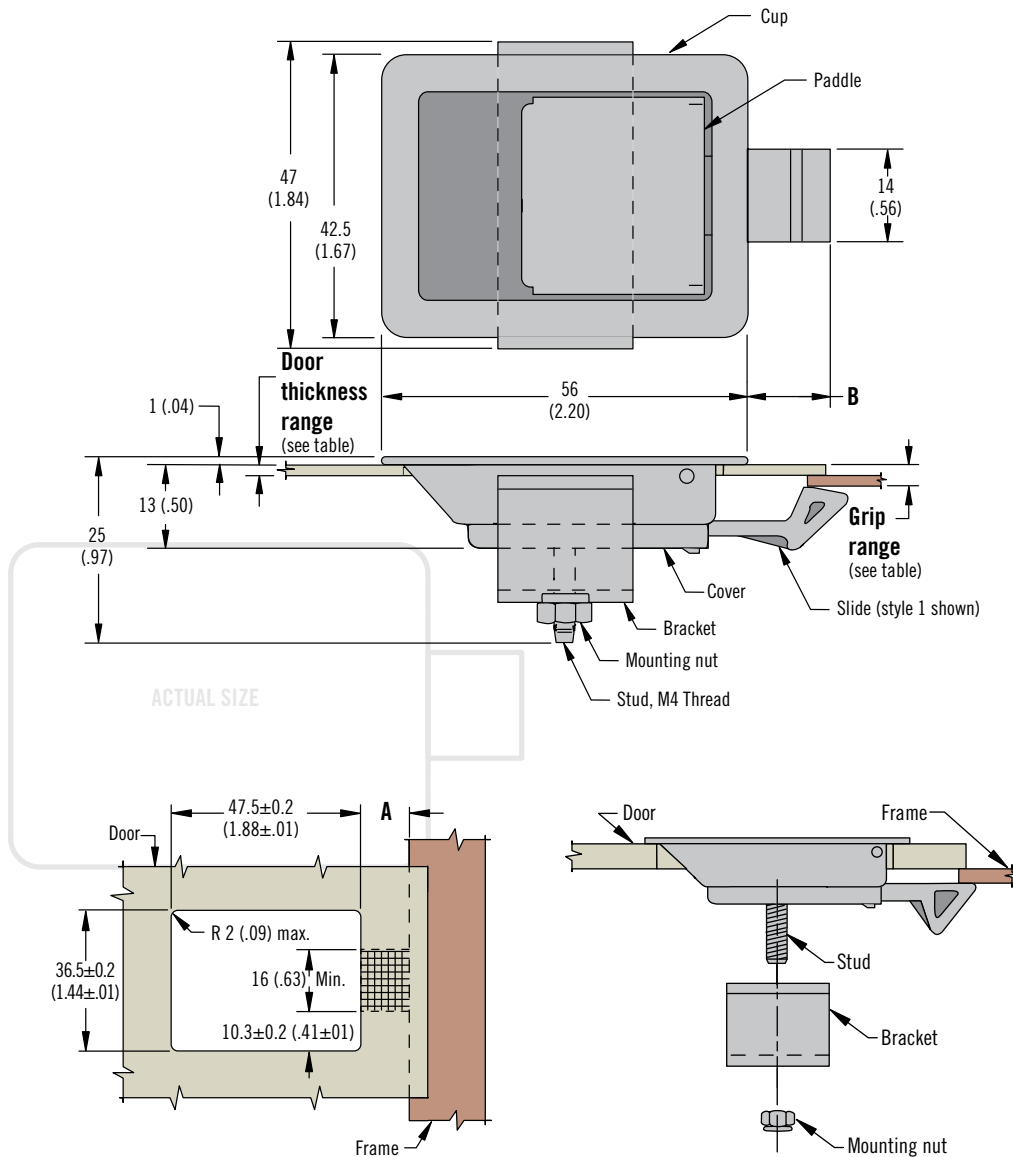

- Single hole installation
- Concealed mounting
- Plastic slide



### Material and Finish

Stainless steel passivated and brushed or black powder coated and glass reinforced nylon, natural

### Performance Details

Max. working load:

Style	Max. Static Load N (lbf)
1	130 (30)
2	110 (25)
3	90 (20)
4	70 (15)
5	55 (12)

Operating temperature range:  
-18°C (0°F) to 100°C (210°F)

Flammability rating: UL94-V0

### Installation Notes

Door thickness must not exceed T dimension (see table) in area through which slide will operate. It may be necessary to reduce thickness of door in area indicated by grid.

Slide styles:

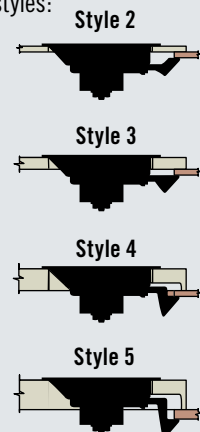

Grip Range		Slide Style	A		B	T (See Notes)	Part Number Brushed Finish			
Min.	Max.		Min.	Max.			Door Thickness Range			
							3.7 (.144) Max.	3.9 - 7.3 (.154 - .288)	11.1 - 14.6 (.437 - .576)	18.6 - 22 (.734 - .868)
1.2 (.05)	2 (.08)	1	10.4 (.41)	12.7 (.50)	12.4 (.49)	1.6 (.063)	64-10-111-50	~	~	~
2.8 (.11)	3.6 (.14)	2	11.9 (.47)	14.2 (.56)	14.2 (.56)	3.2 (.125)	64-10-113-50	64-10-133-50	~	~
6 (.23)	6.7 (.27)	3				6.4 (.250)	64-10-124-50	64-10-114-50	~	~
12.3 (.48)	13.1 (.52)	4				7.1 (.281)	64-10-125-50	64-10-135-50	64-10-115-50	64-10-115-50
18.6 (.73)	19.4 (.77)	5				7.1 (.281)	64-10-126-50	~	64-10-116-50	64-10-116-50

### Notes

For an assembly with black powder coated finish change last digit from 0 to 5 - Example: 64-10-111-55



# 64 Push-to-Close Latch

Pull-to-open · Paddle latch · Medium

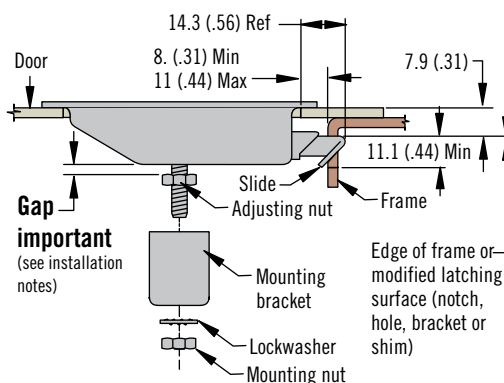
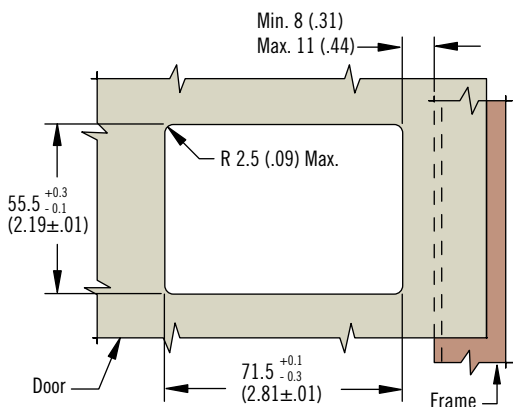
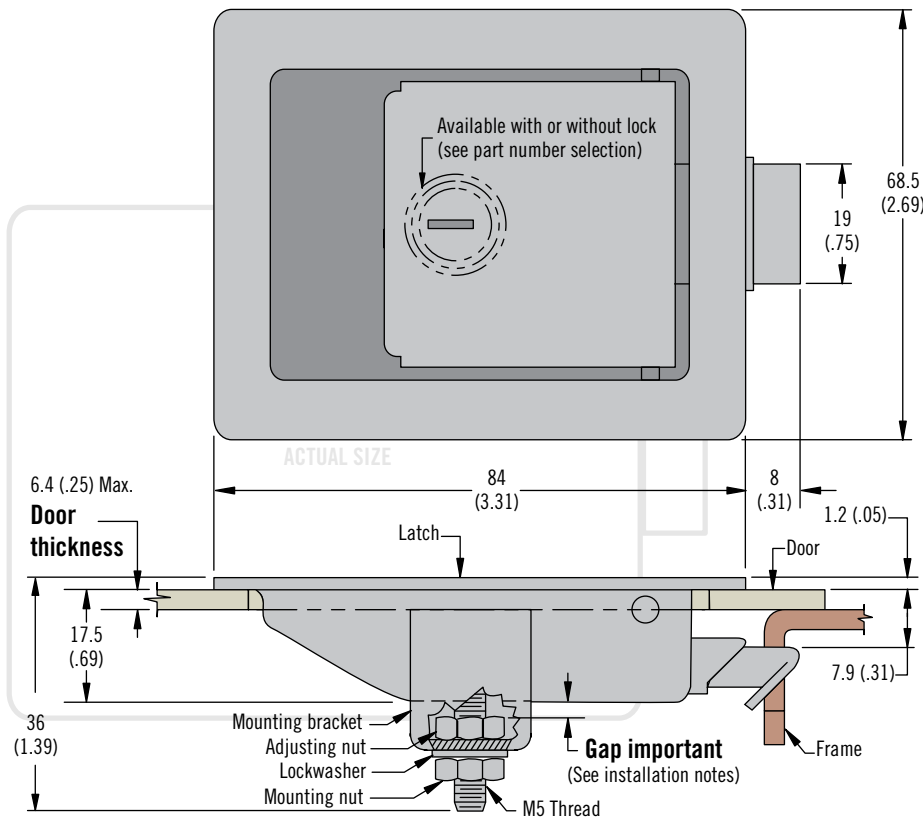

- Single hole installation
- Concealed mounting
- Metal slide

### Material and Finish

Stainless steel brushed, steel, zinc plated or steel, black powder coated or silver

### Performance Details

Max. working load:  
570 N (125 lbf)

### Installation Notes

Measure your door thickness and set adjusting nut so that GAP is equal to door thickness within plus 0.8 (.03), minus 0.0 (.00).

### Accessories

Flat key, keyed alike H257  
(2 keys per ring)  
Part number: 64-0-33578

### Part Number Selection

64 - 2 L - 1 M

#### L Lock style

- 1 Non-locking
- 2 Key-locking keyed alike H257 (2 keys supplied)

#### M Material

- 0 Stainless steel, brushed
- 1 Steel, black powder coated
- 3 Steel, zinc plated
- 5 Steel, powder coated silver



# 64 Push-to-Close Latch

Pull-to-open · Paddle latch · Large

- Single hole installation
- Concealed mounting
- Metal slide

### Material and Finish

Stainless steel, brushed, steel, zinc plated or steel, black powder coated

### Performance Details

Max. working load: 1110 N (250 lbf)

### Installation Notes

Measure your door thickness and set adjusting nut so that GAP is equal to door thickness within plus 0.8 (.03), minus 0.0 (.00)

### Accessories

Flat key, keyed alike CH751 (2 keys per ring)  
Part number: PK-10-01



Overmolded key, keyed alike CH751 (2 keys per ring)  
Part number: PK-10-01-05

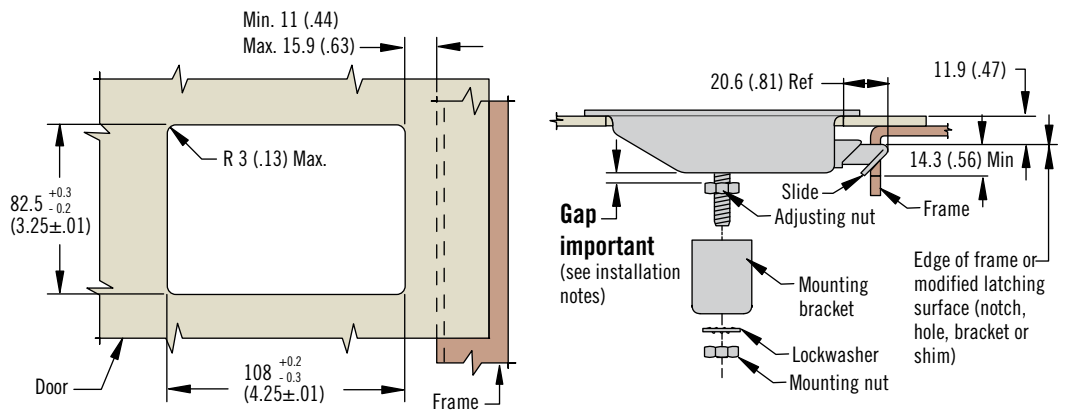
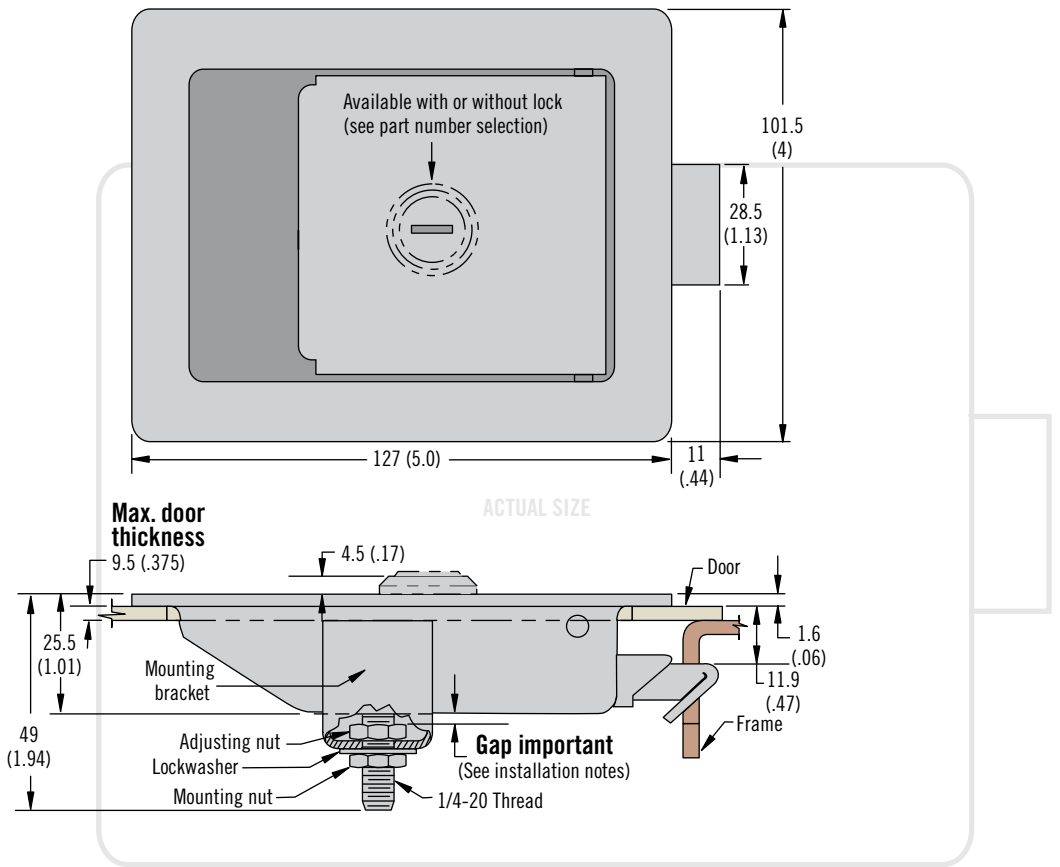

### Part Number Selection

**64 - 10 - 30** **L** - **M** **0**

**M** Material

- 4 Steel, zinc plated
- 5 Stainless steel brushed
- 9 Steel, black powder coated

- L** Lock style
- 1 Non-locking
  - 2 Key-locking keyed alike H257 (2 keys supplied)

# 64 Push-to-Close Latch

Pull-to-open · Paddle latch · Large

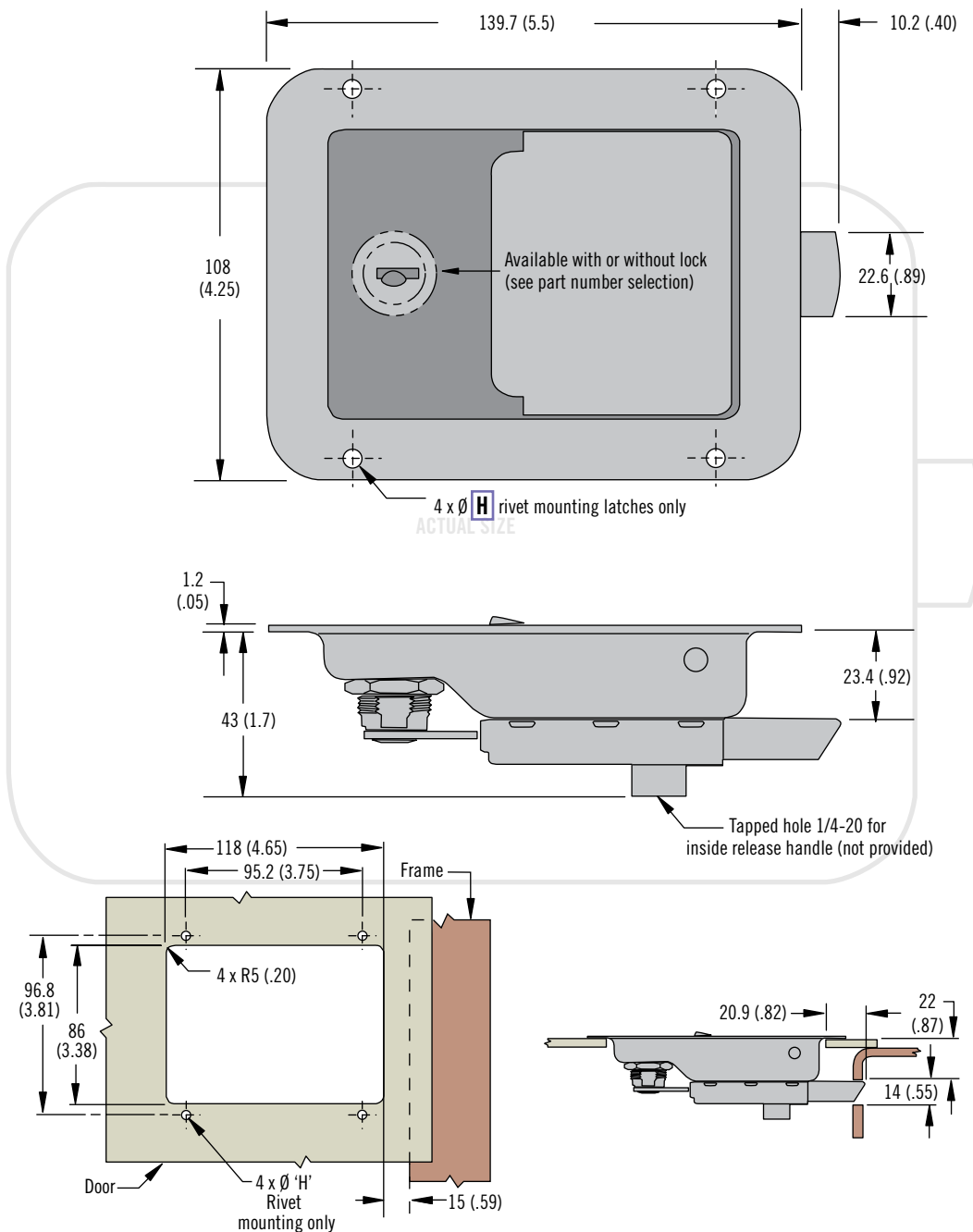

- Single hole installation
- Multiple mounting styles
- Inside actuation in locked or unlocked position

### Material and Finish

Stainless steel, polished, steel, zinc plated or steel, black powder coated  
 Slide bolt and lock assembly:  
 Zinc plated or powder coated

### Performance Details

Max. working load: 560 N (125 lbf)

### Accessories

Flat key, keyed alike CH751  
 (2 keys per ring)  
 Part number: PK-10-01



Overmolded key, keyed alike CH751  
 (2 keys per ring)  
 Part number: PK-10-01-05



### Part Number Selection

**64 - 50 - 4 L H - M**

**L Lock style**  
 0 Non-locking  
 1 Key-locking keyed alike CH751 (2 keys supplied)

**H Housing**  
 0 Weld  
 1 Rivet through hole 4.9 (.19)  
 2 Rivet through hole 5.2 (.20)

**M Material**  
 10 Steel, zinc plated  
 20 Stainless steel polished  
 50 Steel, black powder coated



# 64 Push-to-Close Actuator

Pull-to-open · Paddle handle actuator · Multi-point · Large

- For use with R4 rotary latches
- Multiple mounting styles

### Material and Finish

Stainless steel, polished, steel, zinc plated or black powder coated

### Accessories

Flat key, keyed alike CH751  
(2 keys per ring)  
Part number: PK-10-01



Overmolded key, keyed alike CH751  
(2 keys per ring)  
Part number: PK-10-01-05



### Notes

Contact Southco for recommended cable or rods

For applicable rotary latches see page 121

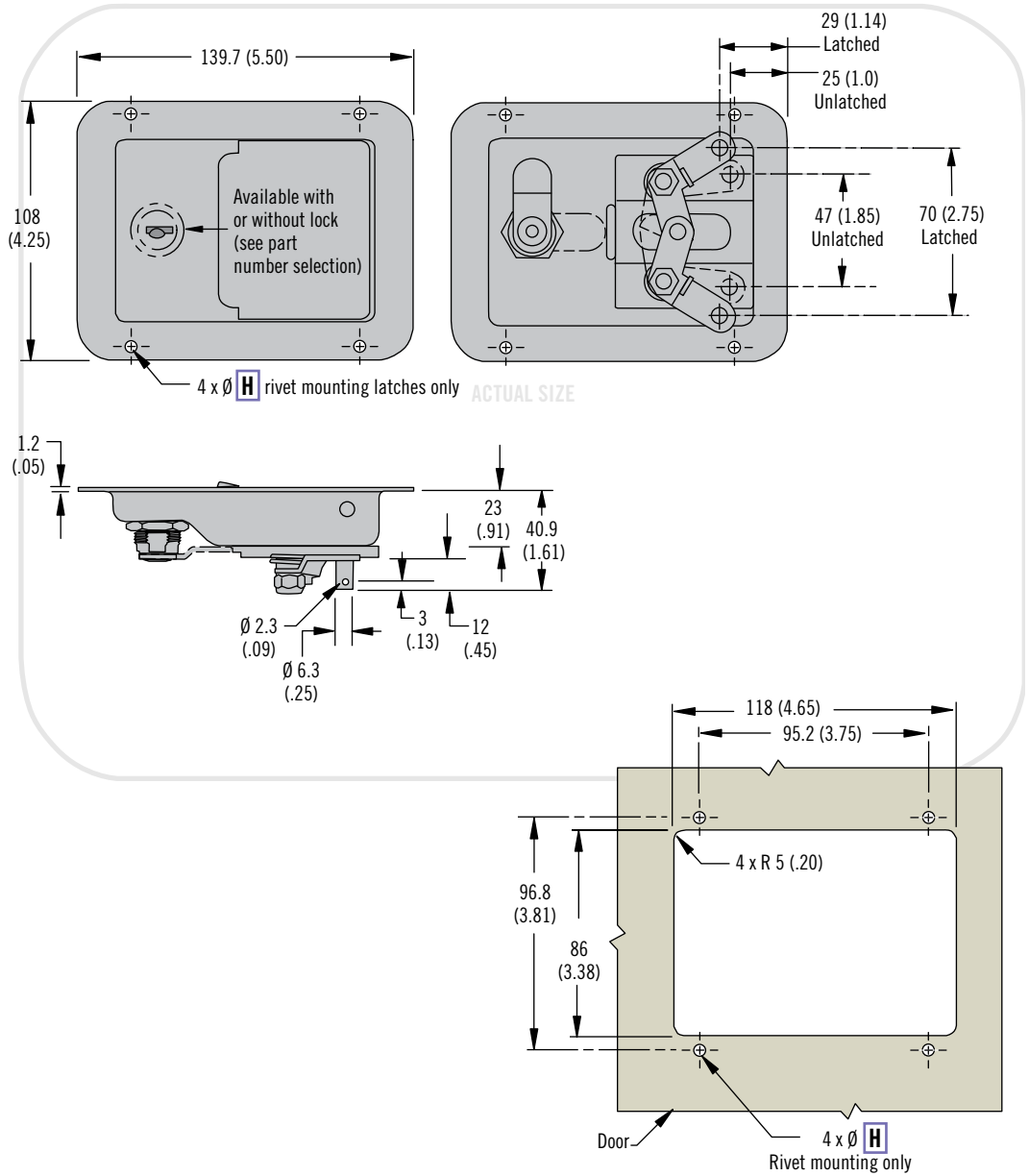

### Part Number Selection

<b>H</b> Housing	←	<b>M</b> Material
0 Weld		10 Steel, zinc plated
1 Rivet through hole 4.9 (.19)		20 Stainless steel, polished
2 Rivet through hole 5.2 (.20)		50 Steel, black powder coated

**64 - 40 - 4 L H - M**

<b>L</b> Lock style	←
0 Non-locking	
1 Key-locking keyed alike CH751 (2 keys supplied)	

Dimensions in millimeters (inch) unless otherwise stated

# 64 Push-to-Close Latch

Pull-to-open · Paddle latch · Heavy-duty pivot

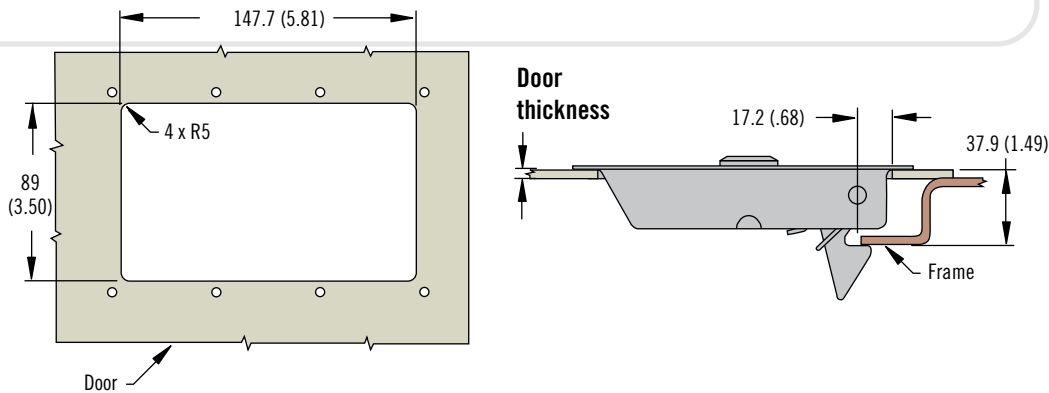
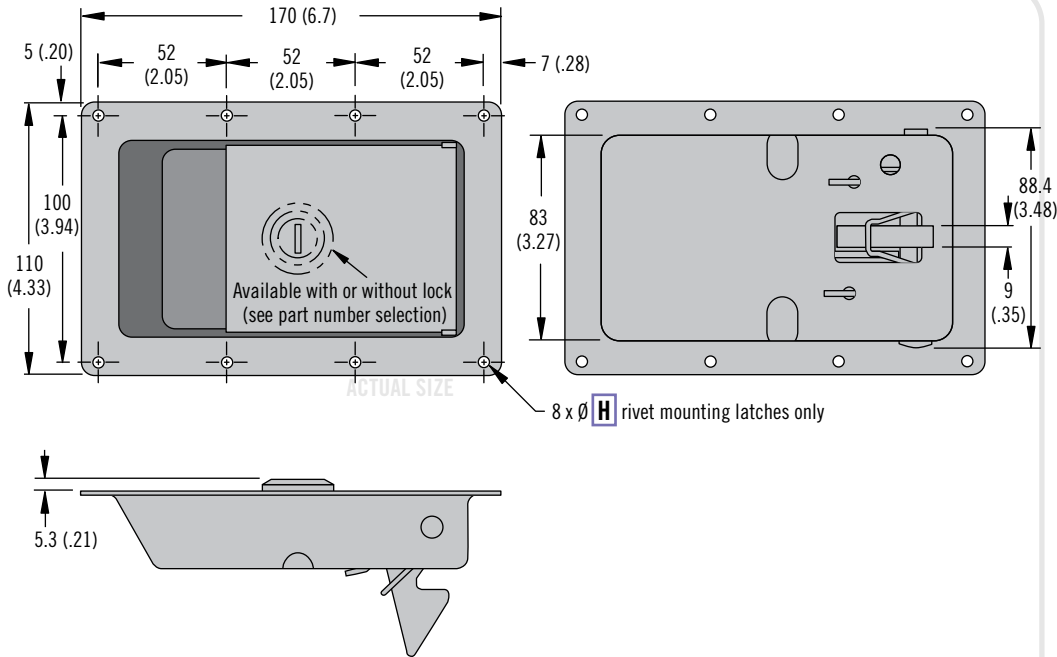

- Robust design resists binding from dirt and debris
- Multiple mounting styles

### Material and Finish

Steel, zinc plated or black powder coated

Slide bolt and lock assembly:

Zinc plated or powder coated

### Performance Details

Max. working load: 2700 N (607 lbf)

### Accessories

Flat key, keyed alike 14603

(2 keys per ring)

Part number: PK-10-01-14603



### Part Number Selection

**64 - 60 - 5 L H - M**

**L** Lock style  
 0 Non-locking  
 1 Key-locking keyed alike 14603 (2 keys supplied)

**H** Housing  
 0 Weld  
 1 Rivet through hole 4.9 (.19)  
 2 Rivet through hole 5.2 (.20)

**M** Material  
 10 Steel, zinc plated  
 50 Steel, black powder coated