



C2 Compression Latch

Lever latch

- Low profile when latched
- Easy grip adjustment
- Push button actuation
- Optional Sealing

Material and Finish

Zinc alloy, powder coated or chrome plated and steel, zinc plated

Performance Details

Maximum static load: 200 N (45 lbf)

Sealing Notes

For sealed option, NEMA 4 / IP65 sealing is achieved by using the supplied flange gasket.

Installation Notes

* For door thickness greater than 5 (.20) calculate screw length using the following formula:
Door thickness + 12 (.47)

Accessories

Rubber Bumper:
Part Number: C2-25-301-82
(reduces min. and max. grip by 1.6 (0.06))



Keys

See page 121

Part Number Selection

See table

Notes

For lock core selection and a complete overview of the *SOUTHCO*® Key-Choice System see page 190

C2 Non-Sealed

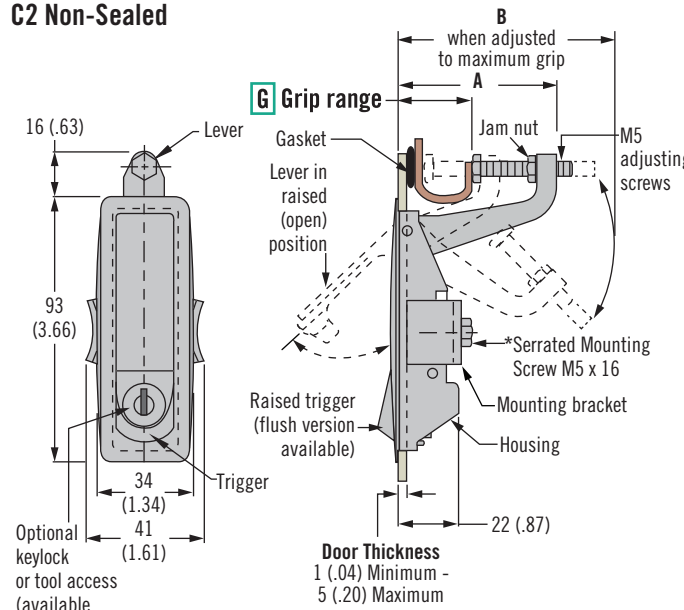

C2 Sealed

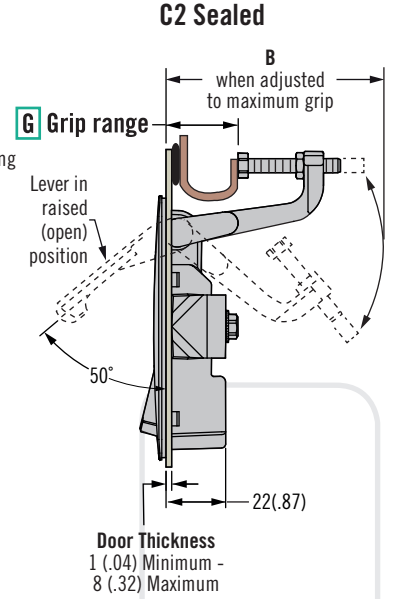

L Lock Styles

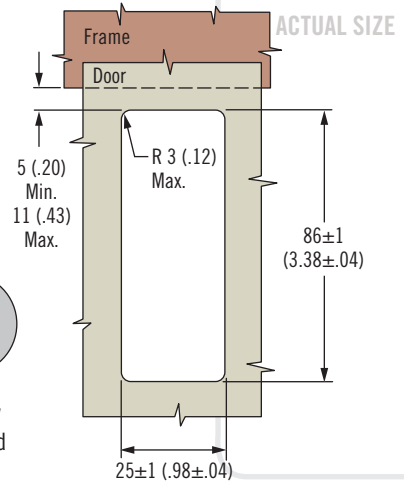
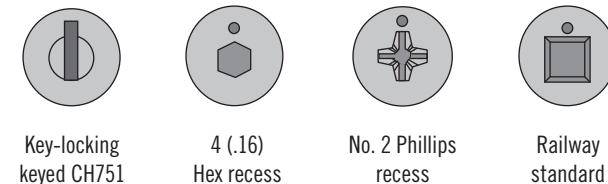

L Lock style

- 1 Non-locking raised trigger
- 2 Key-locking raised trigger keyed CH751 (two flat keys supplied)
- 3 Non-locking flush trigger
- 4 4 (.16) Hex recess raised trigger
- 10 No. 2 Phillips recess raised trigger
- 13 Locking without lock core raised trigger (see page 190 for lock core options)
- 14 Railway standard raised trigger

F Finish

- 1 Textured chrome
- 5 Black powder coated

P Packaging option

- 3 Layer packed (omit for individually packaged latches)

C2 - S G - L F - P

S Sealing Option

- 3 Non-sealed
- 4 Sealed

G Grip Range	A	B
2	1 - 24 (.04 - .95)	35 (1.38) 63 (2.48)
3	23 - 46 (.91 - 1.81)	57 (2.24) 84 (3.31)

C2 Compression Latch

Lever latch · Access indicator of latch access



Visual Indicator

Green – Unaccessed
Red – Accessed (Operated)

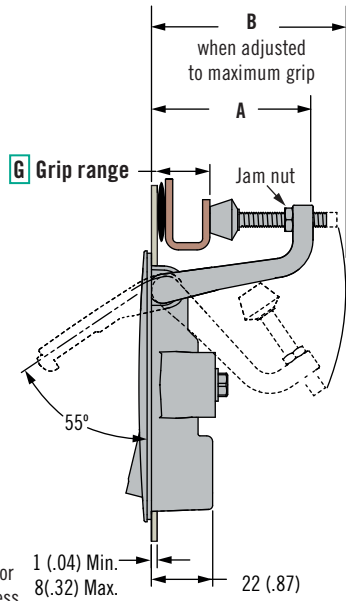
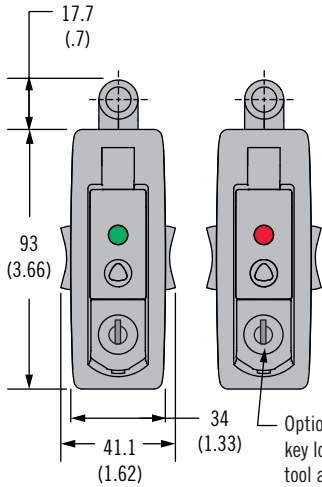

Panel Preparation

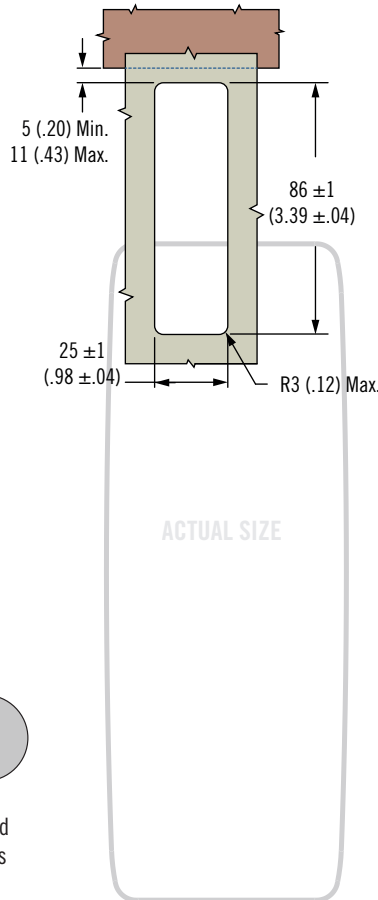

L Lock Styles



Key-locking keyed CH751 4 (.16) Hex recess No. 2 Phillips recess Railway standard Slotted recess

- Feature indicates that latch has been accessed
- Easy grip adjustment
- Push button actuation
- Integrated bumper screw

Material and Finish

Zinc alloy, powder coated or chrome plated and steel, zinc plated

Performance Details

Maximum static load: 200 N (45 lbf)

Sealing Notes

NEMA 4 and IP65 enabled using supplied gasket.

Installation Notes

* For door thickness greater than 5 (.20) calculate screw length using the following formula:
 Door thickness + 12 (.47)

Keys

See page 121

Indicator Reset Key

Part number: C2-26-301-05
 Required to reset red indicator back to green



Part Number Selection

See table

Notes

For lock core selection and a complete overview of the *SOUTHCO*® Key-Choice System see page 190

Make Safety Visible™
 by Southco

L Lock style

- 1 Non-locking raised trigger
- 2 Key-locking raised trigger keyed CH751 (two flat keys supplied)
- 3 Non-locking flush trigger
- 4 4 (.16) Hex recess raised trigger
- 10 No. 2 Phillips recess raised trigger
- 13 Locking without lock core raised trigger (see page 190 for lock core options)
- 14 Railway standard raised trigger
- 16 Slotted recess raised trigger

F Finish

- 1 Textured chrome
- 5 Black powder coated

P Packaging option

- 3 Layer packed (omit for individually packaged latches)

C2 - A4 G - L F - P

G Grip Range	A	B
2	1 - 18 (.04 - .71)	35 (1.38) 65 (2.56)
3	17 - 39 (.67 - 1.53)	57 (2.24) 85 (3.35)



C2 Compression Latch

Lever latch · Push to lock

- Low profile when latched
- Easy grip adjustment
- Push button actuation
- Integrated bumper

Material and Finish

Zinc alloy, powder coated or chrome plated and steel, zinc plated

Performance Details

Maximum static load: 200 N (45 lbf)

Installation Notes

* Serrated Mounting Screw M5 x 16. For door thickness greater than 5 (.20) calculate screw length using the following formula:
 Door thickness + 12 (.47)

Keys

See page 121

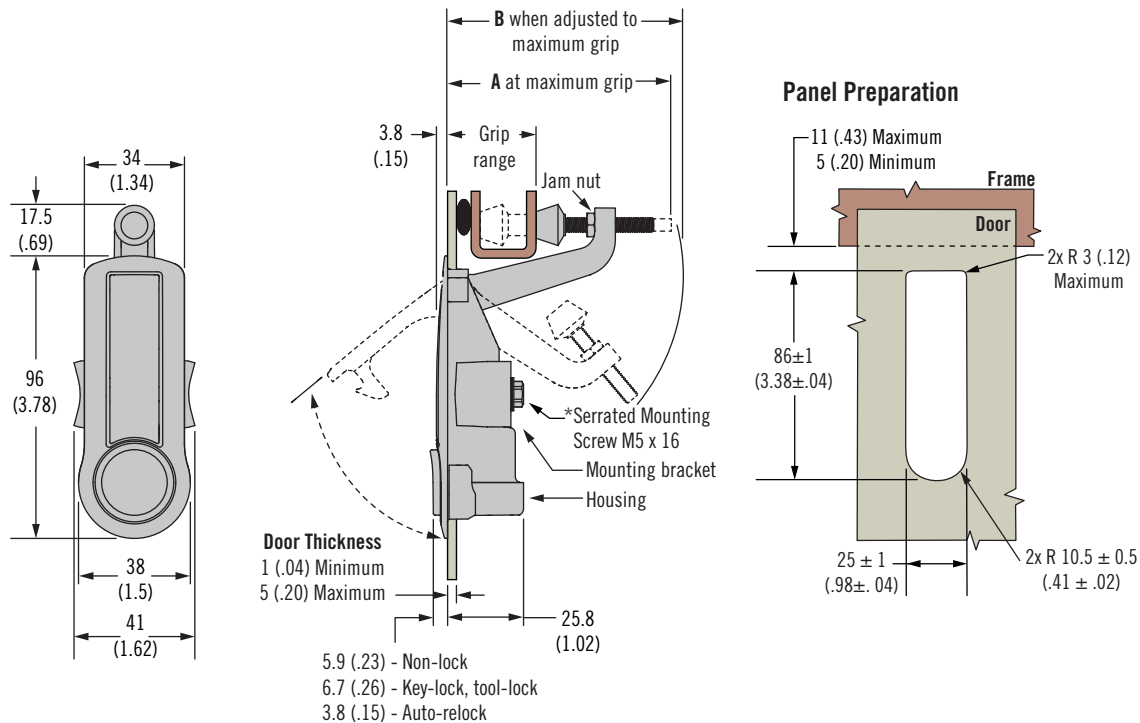

L Lock Styles



Part Number Selection

See table

Notes

For lock core selection and a complete overview of the *SOUTHCO*® Key-Choice System see page 190

L Lock style

- 1 Non-locking raised trigger
- 2 Key-locking raised trigger keyed CH751 (two flat keys supplied)
- 4 4 (.16) Hex recess raised trigger
- 10 No. 2 Phillips recess raised trigger
- 13 Locking without lock core raised trigger (see page 190 for lock core options)
- 14 Railway standard raised trigger
- 15 8 (.32) Hex recess raised trigger
- 16 Slotted recess raised trigger
- 22 Key-locking raised trigger keyed CH751 (two flat keys supplied); (key retained in unlocked position)
- 34 Auto relock: 4 (.16) Hex recess raised trigger
- 310 Auto relock: No. 2 Phillips recess flush trigger
- 314 Auto relock: Railway standard flush trigger
- 315 Auto relock: 8 (.32) Hex recess flush trigger
- 316 Auto relock: Slotted recess flush trigger

F Finish

- 1 Bright chrome
- 5 Black powder coated

P Packaging option

- 3 Layer packed (omit for individually packaged latches)

C2 - 5 G - L F - P

G Grip Range	A	B
2	1-18 (.04-.71)	58 (2.28) 63 (2.48)
3	18-40 (.71-1.57)	80 (3.15) 84 (3.31)