

- GB** Installation Guide
- D** Einbauanleitung
- F** Guide d'installation
- I** Guida all'installazione
- E** Guía de instalación
- PL** Instrukcja montażu

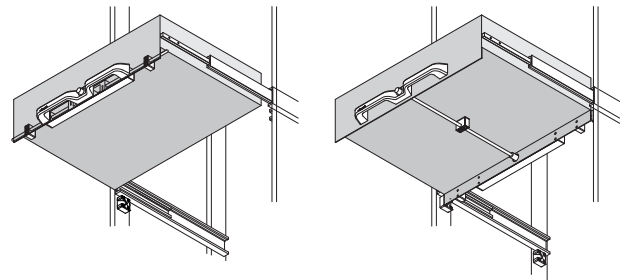

### DBHAND-2/DBHANL-2

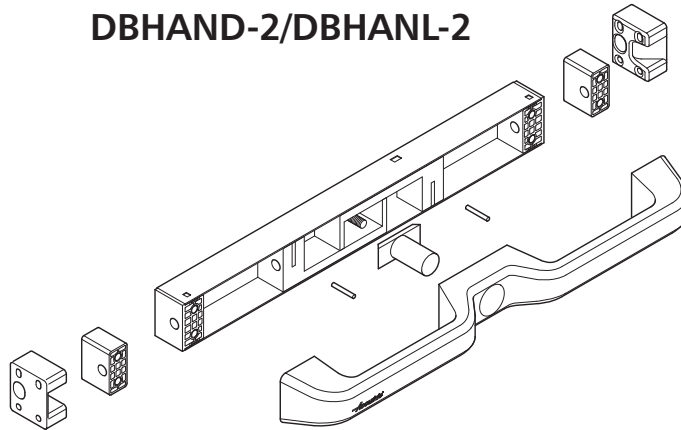

### DYHAN4-5

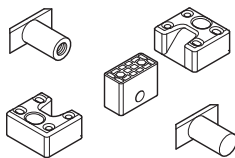

### DSHAN3-0xxx-2

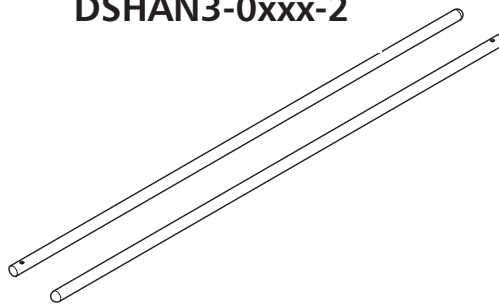

### Accuride International Ltd.

Liliput Road, Brackmills Industrial Estate, Northampton  
NN4 7AS, United Kingdom.

Tel: +44 (0) 1604 761111 Fax: +44 (0) 1604 767190

E-mail: [saleseurope@accuride.com](mailto:saleseurope@accuride.com)

[www.accuride-europe.com](http://www.accuride-europe.com)

### Accuride International GmbH

Werner-von-Siemens-Str. 16-18,  
D-65582 Diez/Lahn, Germany

Tel: + 49 (0) 6432 608-0

Fax: + 49 (0) 6432 608-320

- GB** If you require further assistance, please contact your distribution agent or supplier.  
Accuride reserve the right to alter specifications without notice.
- D** Bei Fragen wenden Sie sich bitte an Ihren Vertriebspartner.  
Technische Änderungen vorbehalten.
- F** Pour de plus amples renseignements, veuillez contacter votre distributeur.  
Accuride se réserve le droit de modifier les spécifications sans préavis.
- I** Necessitate di ulteriore assistenza, contattate il fornitore o il vostro agente.  
Accuride si riserva il diritto di apportare modifiche senza ulteriore comunicazione.
- E** Si necesita más ayuda, póngase en contacto con su agente de distribución o proveedor.  
Accuride se reserva el derecho de alterar las especificaciones sin aviso previo.
- PL** W przypadku dodatkowych pytań proszę zwrócić się do dostawcy.  
Accuride zastrzega sobie prawo do wprowadzania zmian technicznych bez wcześniejszej informacji.

DBHAND-2/DBHANL-2 + DSHAN3-0xxx-2

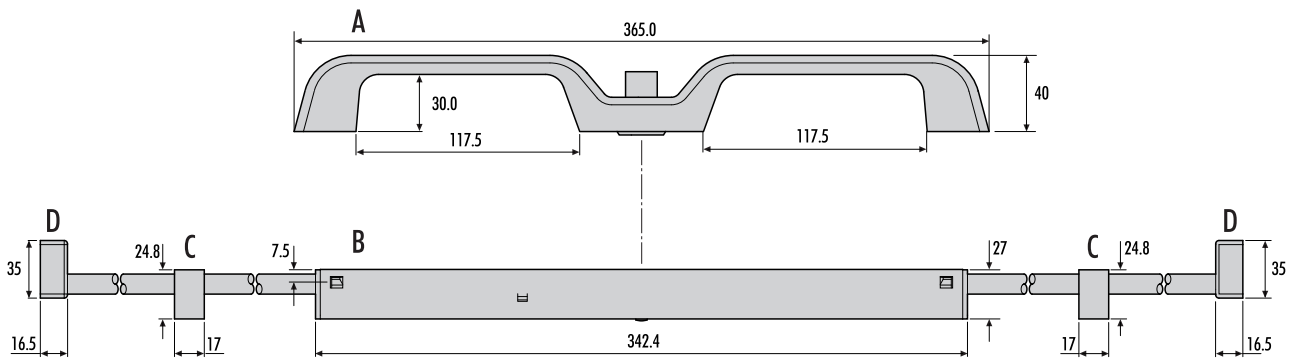
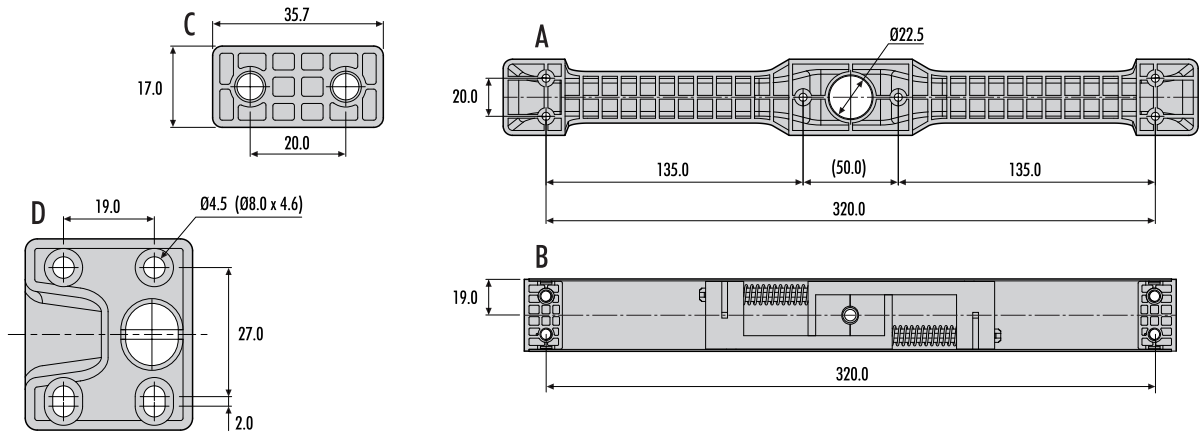

DBHAND-2/DBHANL-2 + DYHAN4-5 + DSHAN3-0xxx-2

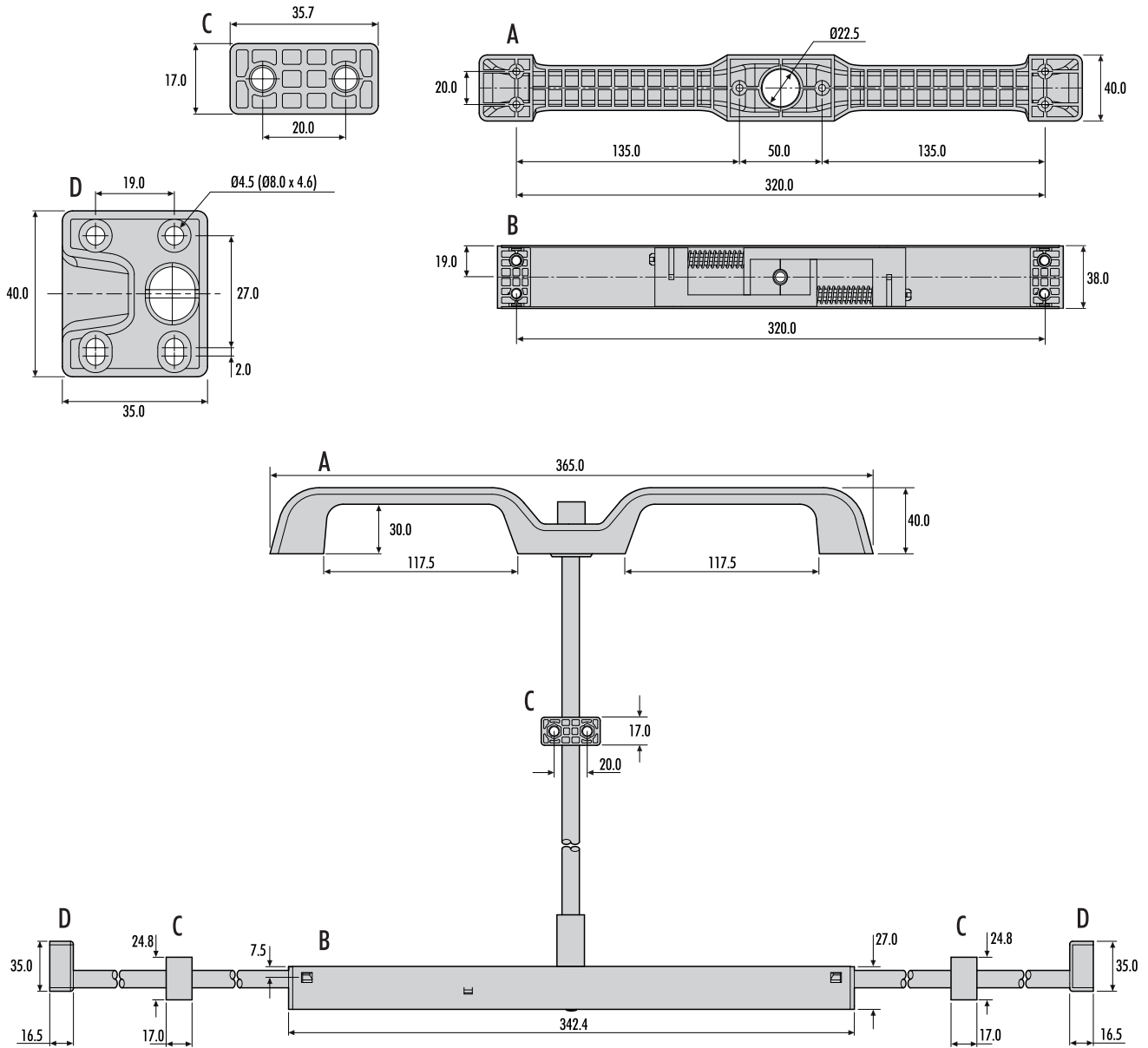

**GB** Lock-in and lock-out

**D** Einhalterung und Rastung

**F** Verrouillage en position fermée et ouverte

**I** Blocco in posizione di apertura e chiusura

**E** Dispositivo de bloqueo en posición

**PL** Blokady w pozycji wsuniętej i wysuniętej

**GB** Lock-out cannot be used on over-extension (100%+) slides.

**D** Verriegelung in geöffneten Position kann nicht für Überauszugs-Schienen (mehr als 100% Auszug) verwendet werden.

**F** Le verrouillage en position ouverte ne peut pas être utilisé avec des glissières à course de plus de 100%.

**I** Il blocco in posizione di apertura non può essere utilizzato per le guide con corsa superiore al 100% di estrazione.

**E** El bloqueo en posición abierta no se puede usar con guías de sobre-extracción (100%+).

**PL** Blokady w pozycji wysuniętej nie może być stosowana z prowadnicami o wysuwie ponadpełnym (100%+).

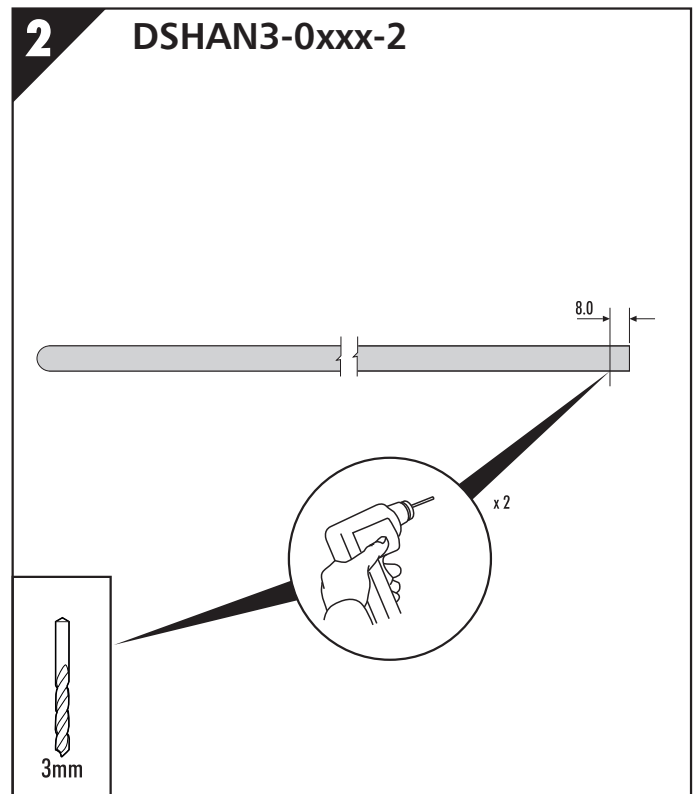
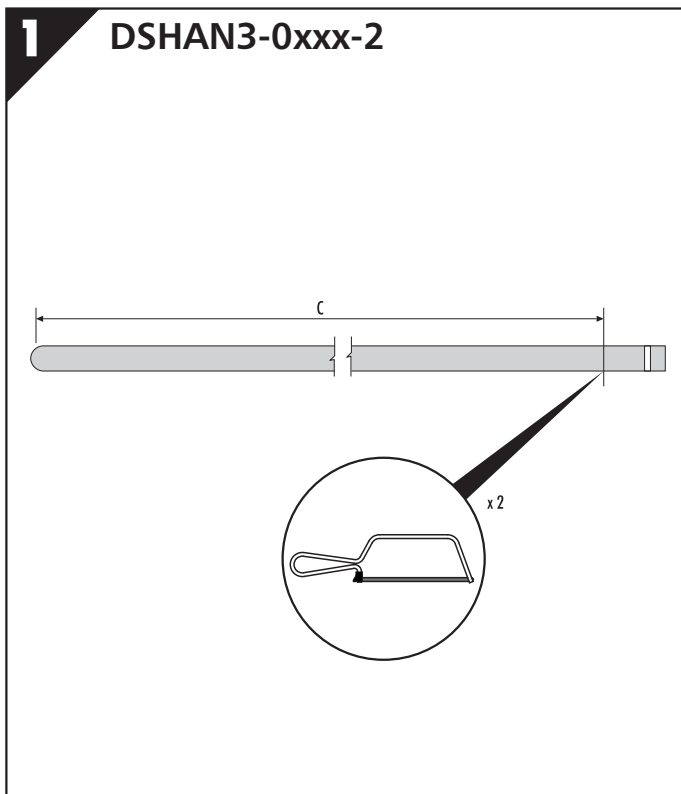
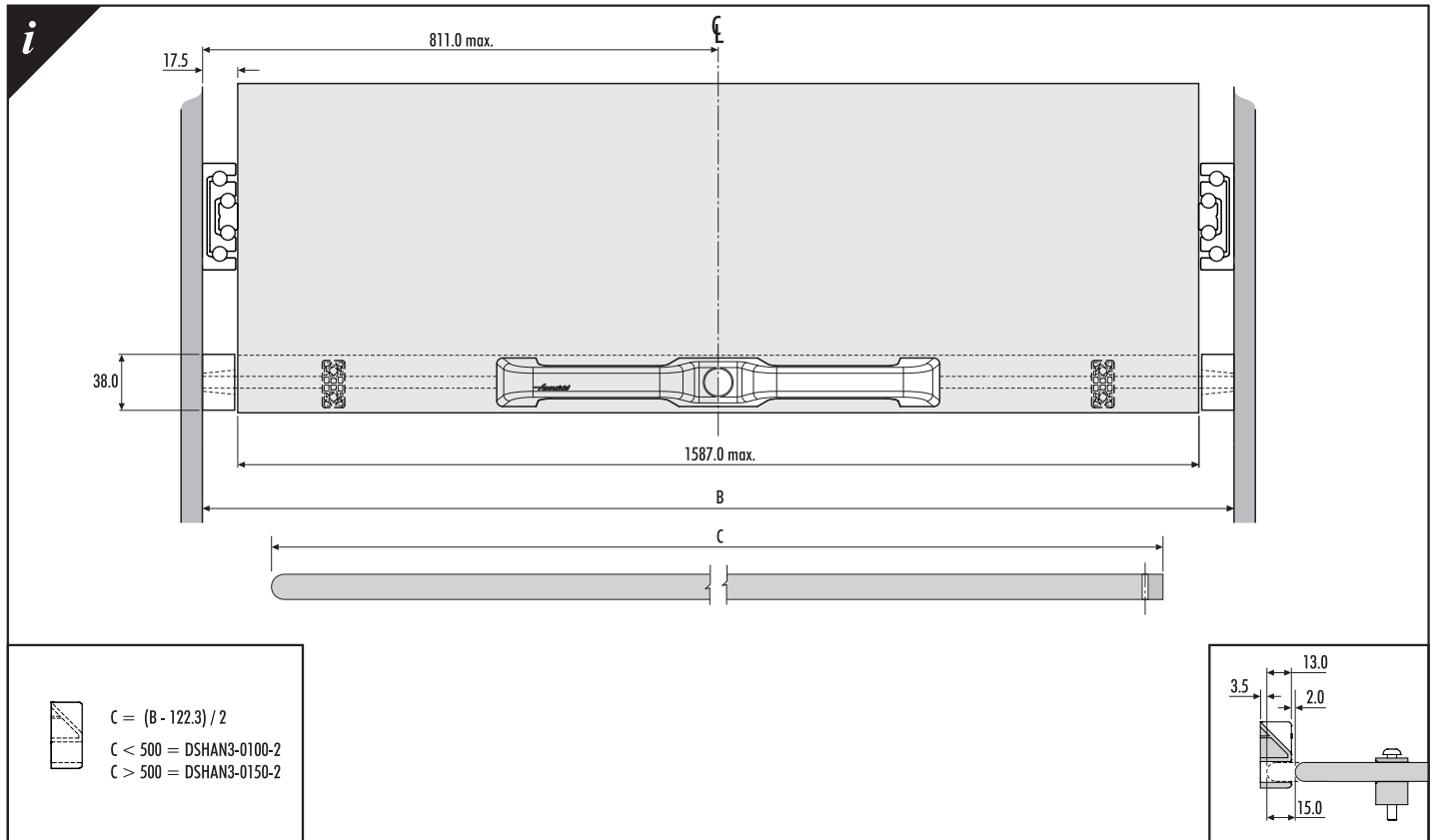

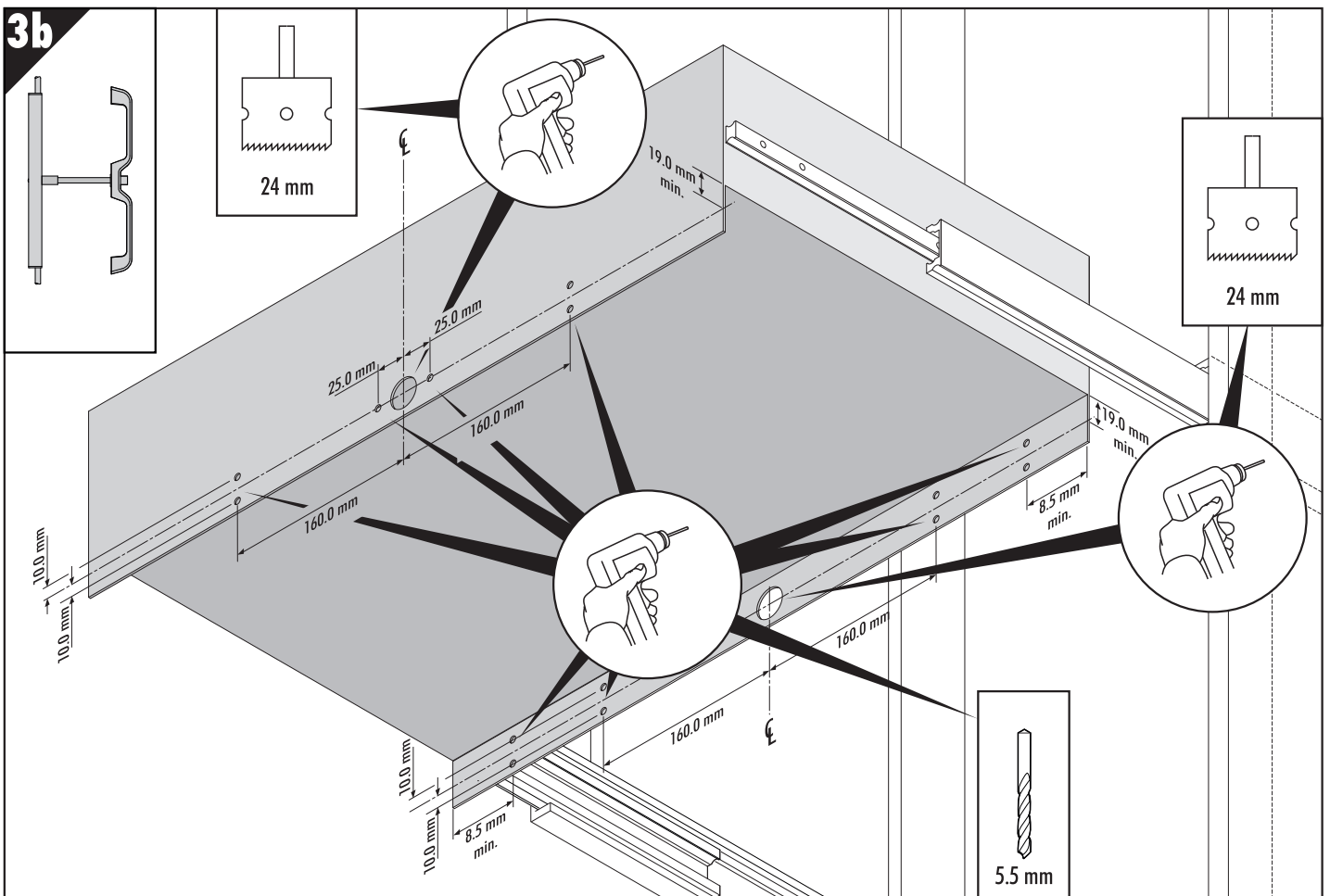
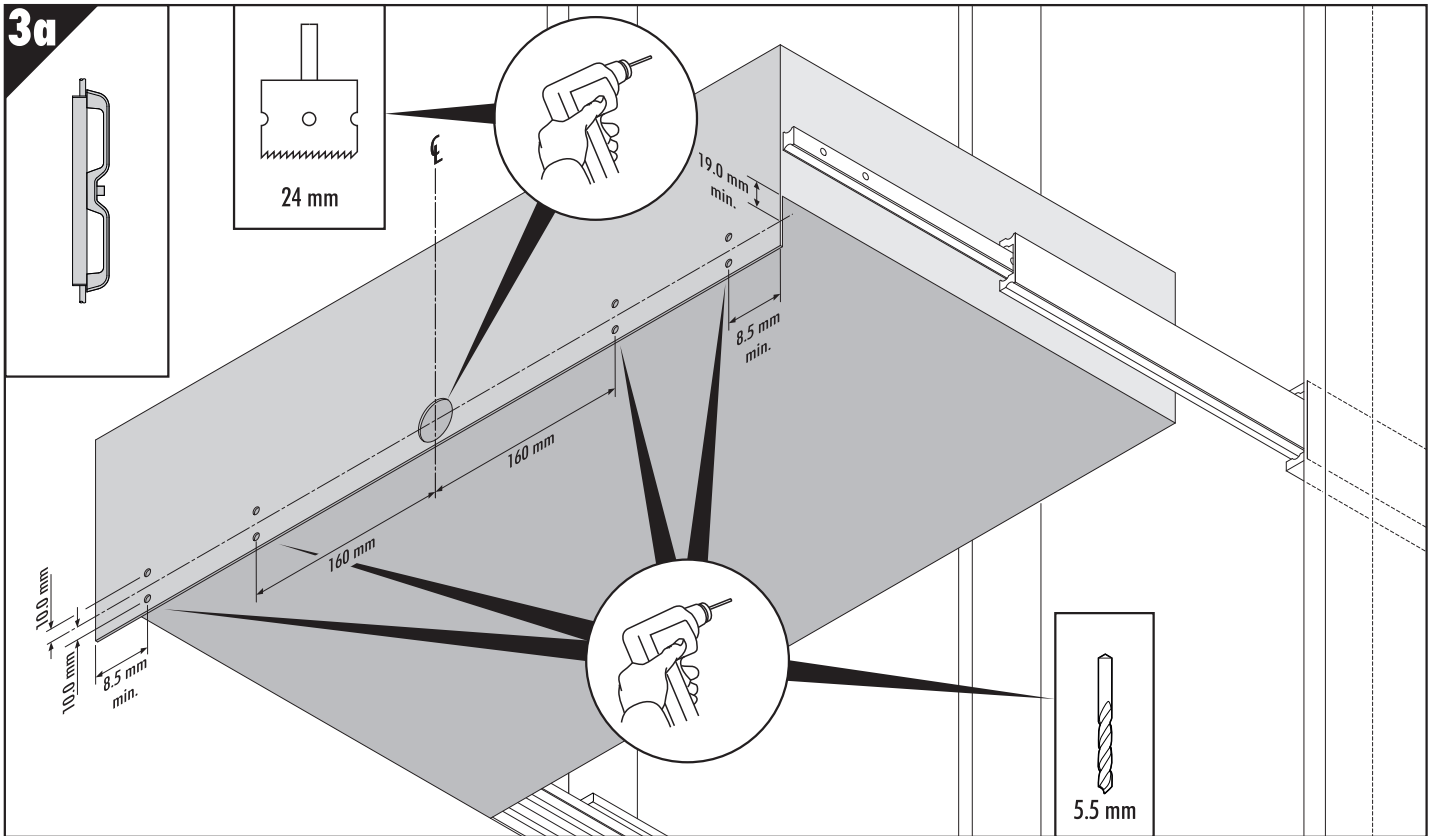

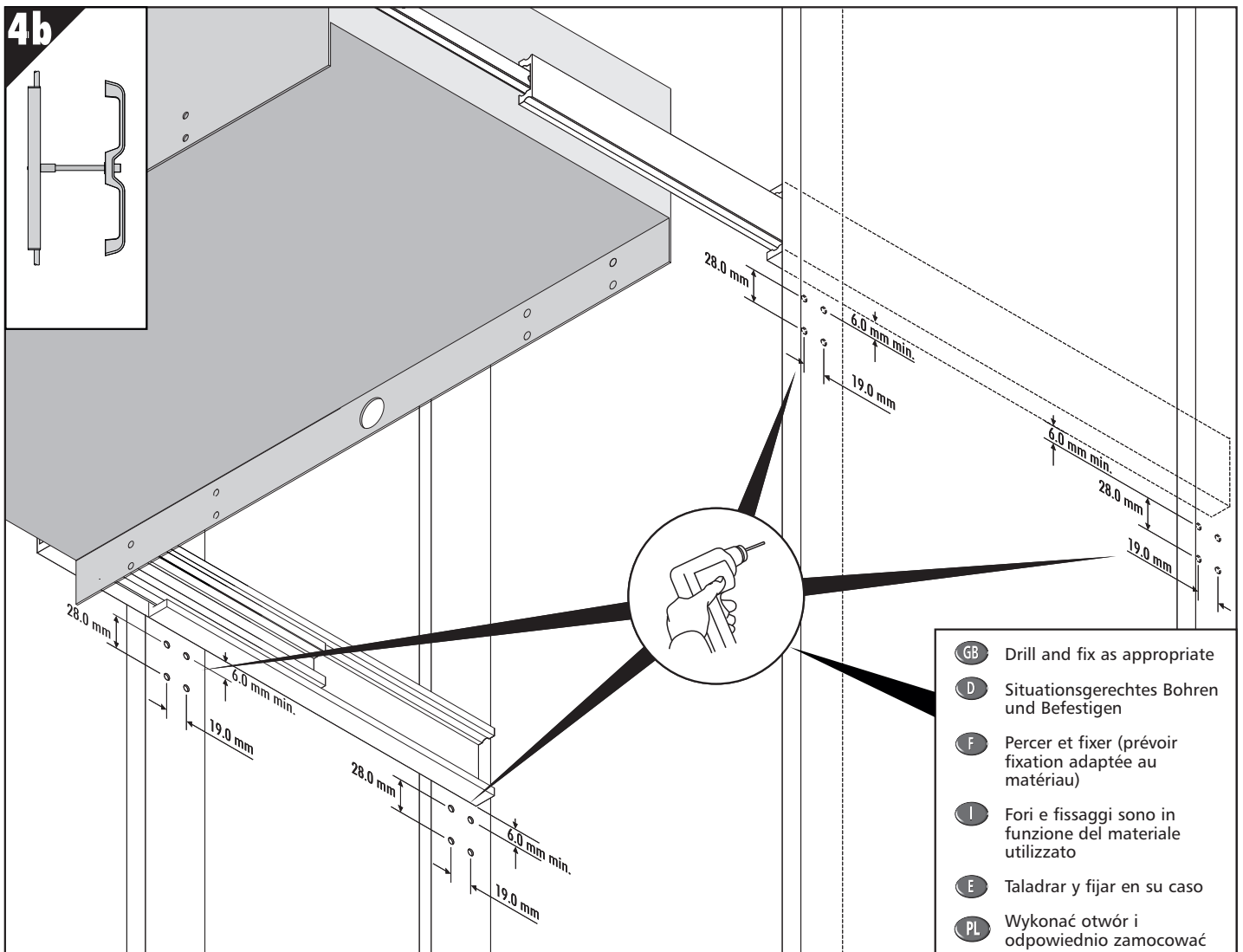
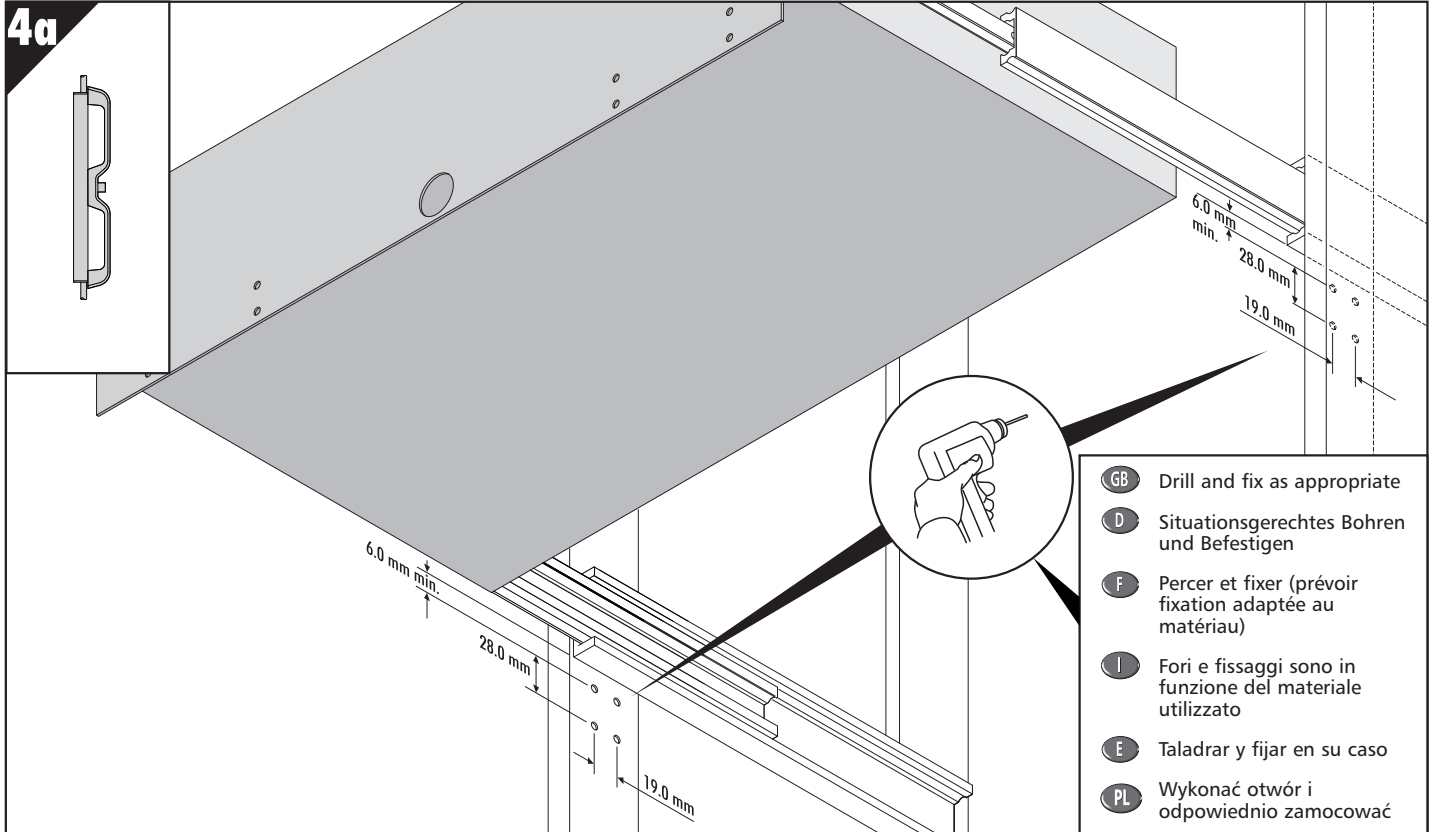

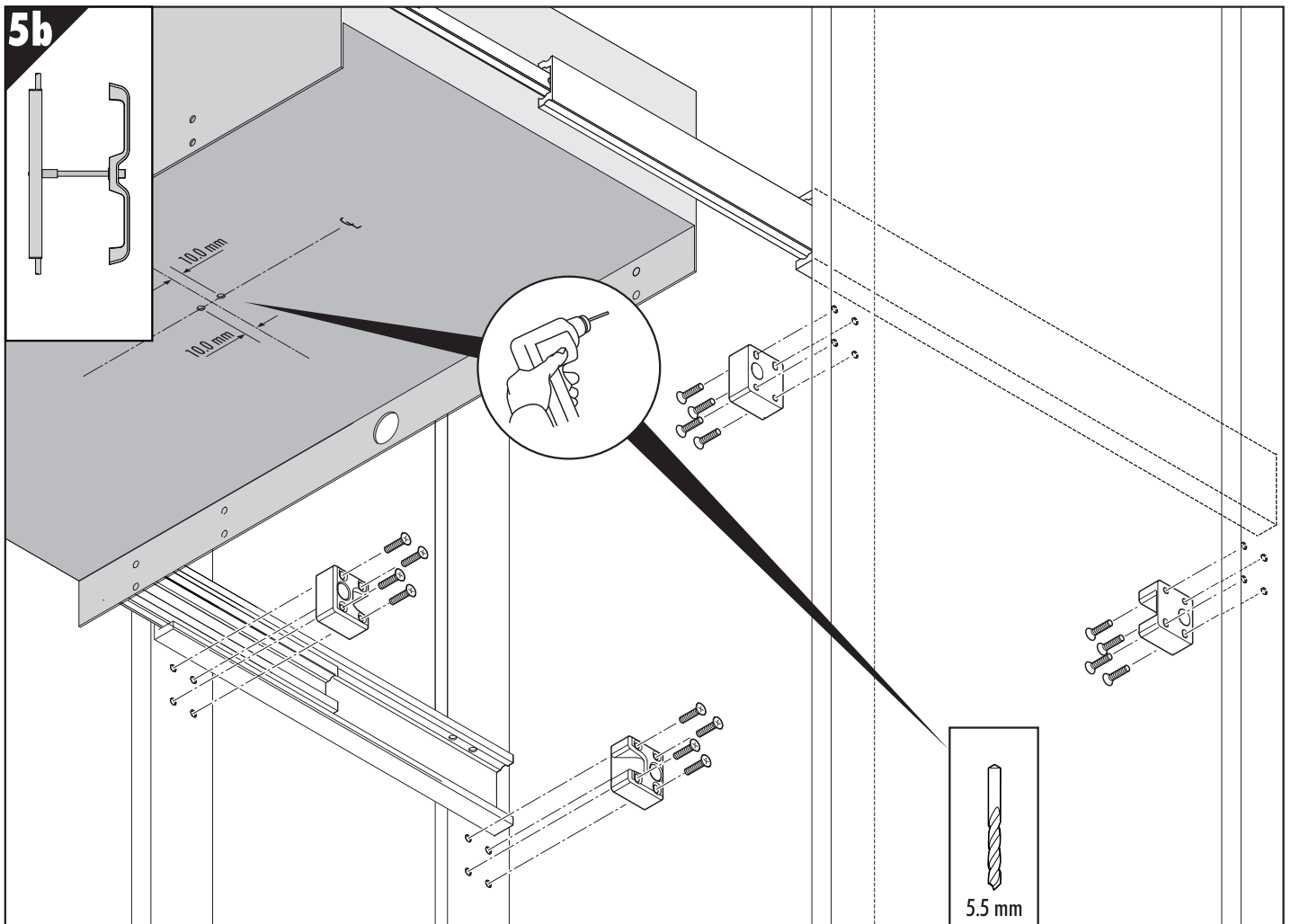
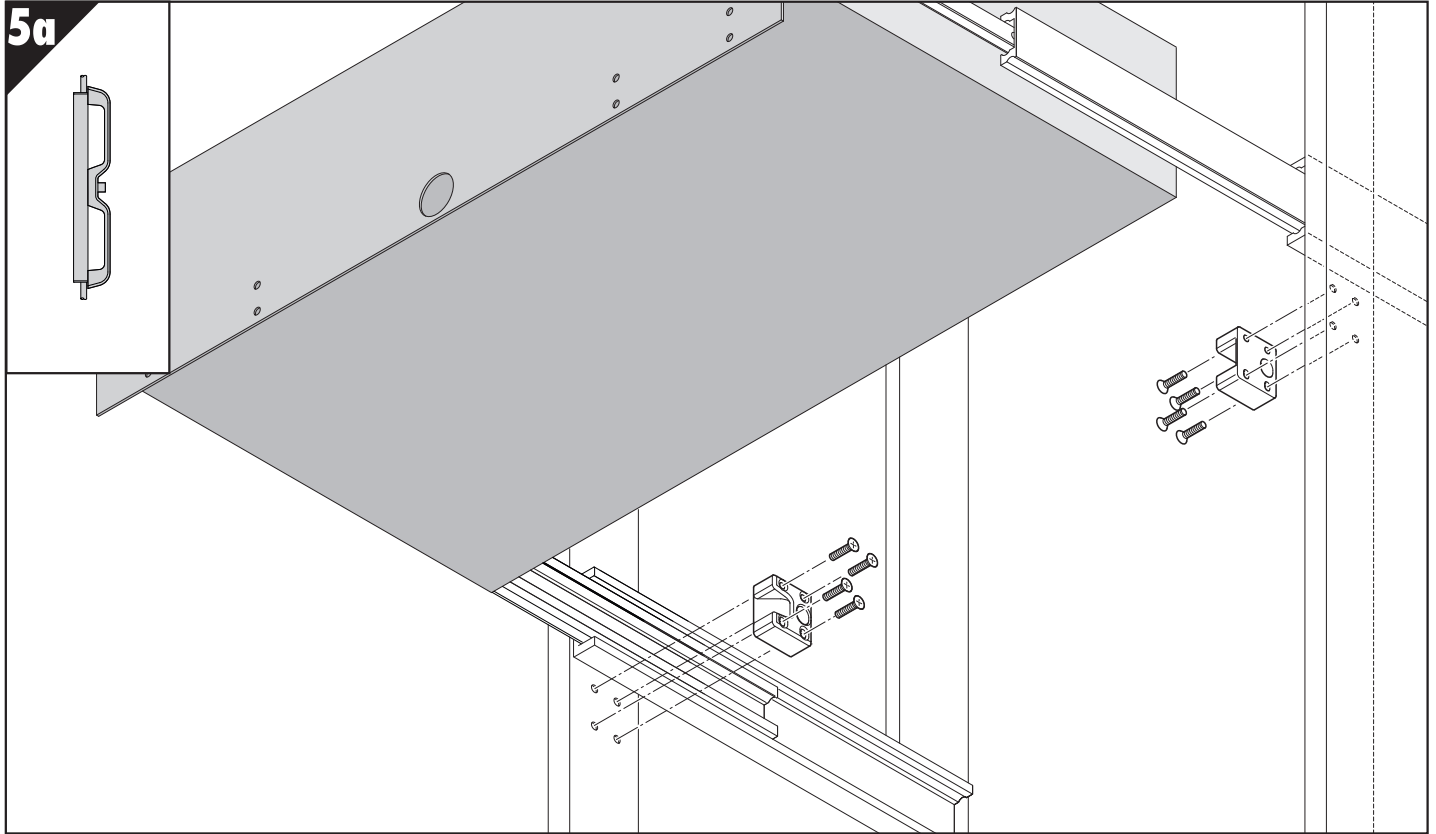

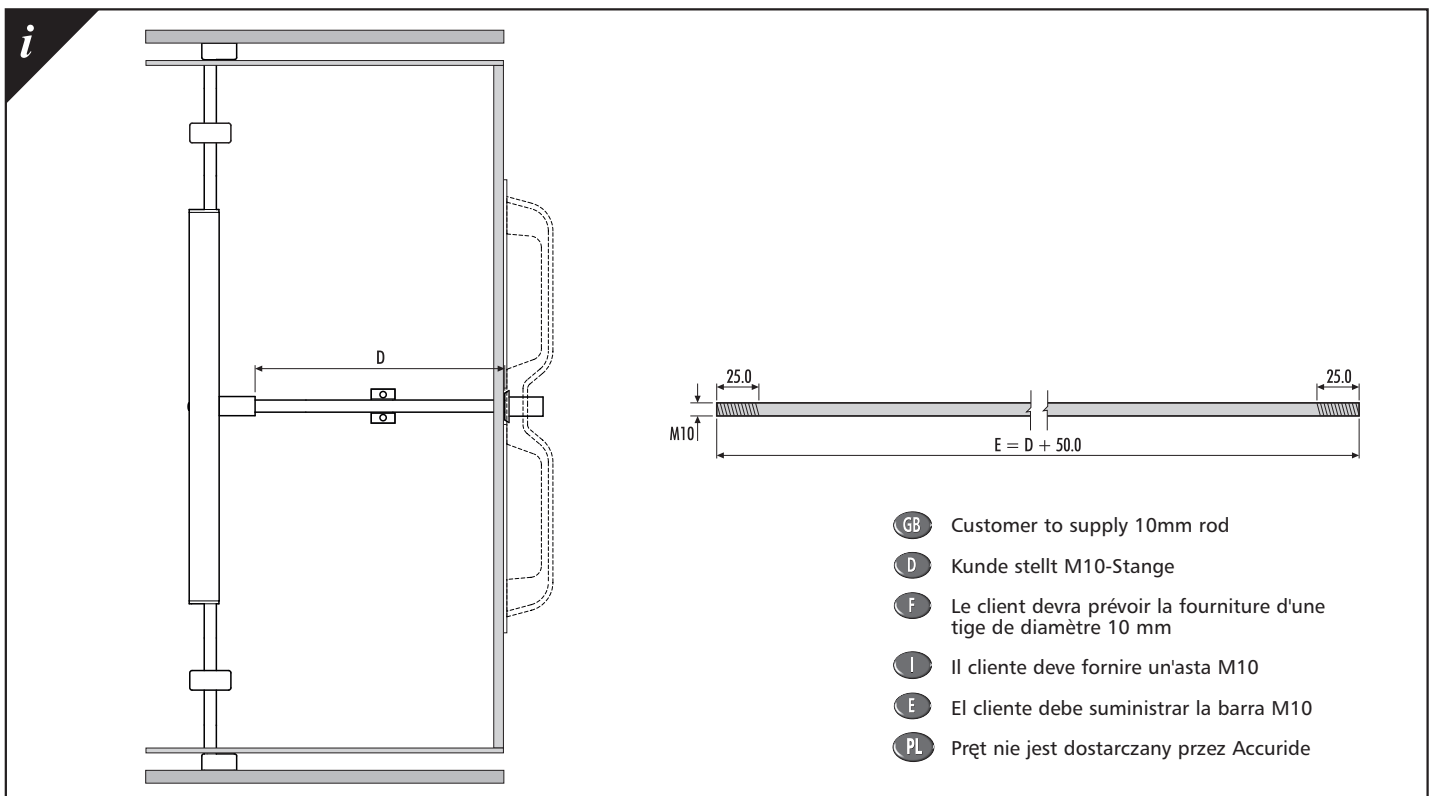
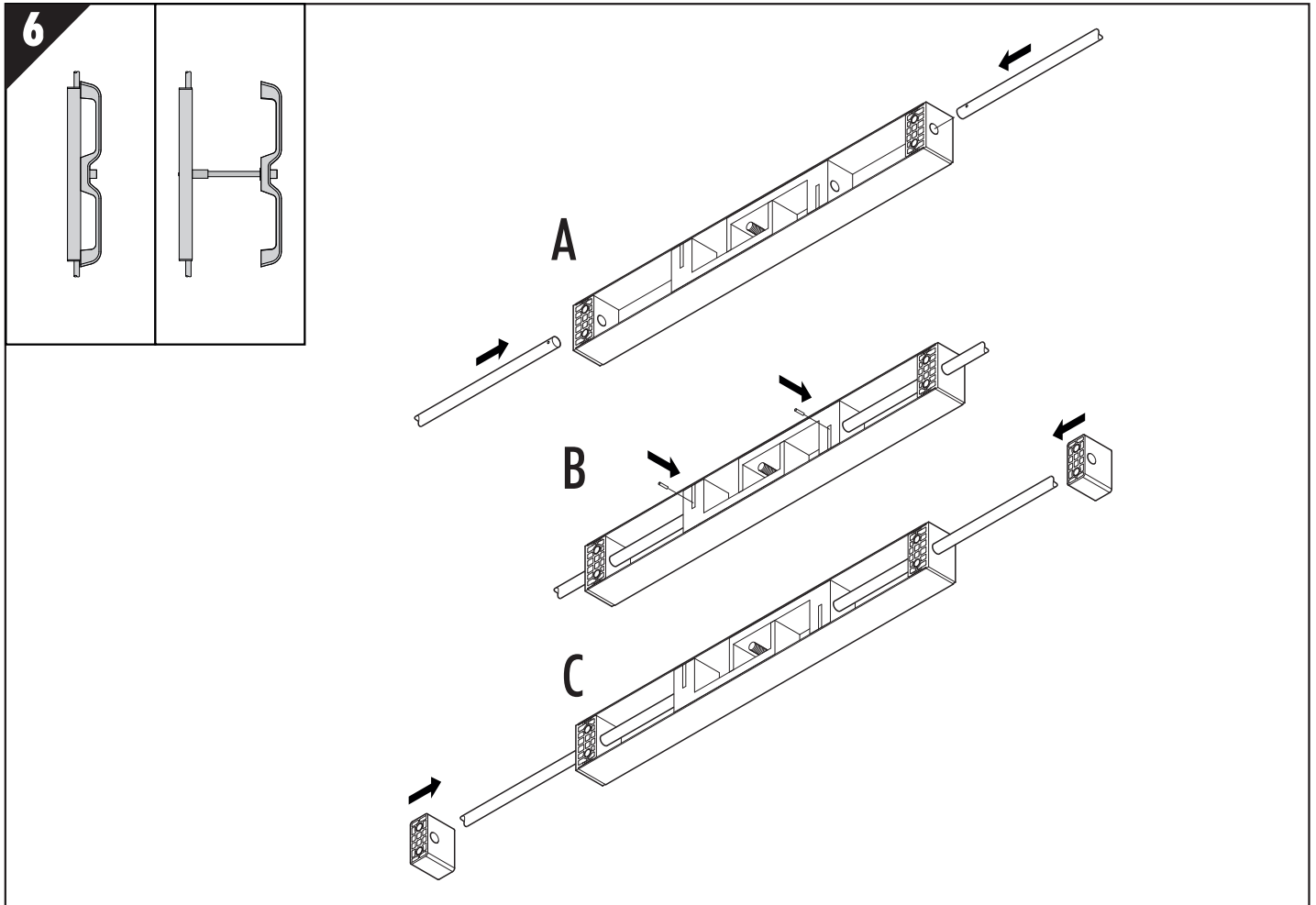





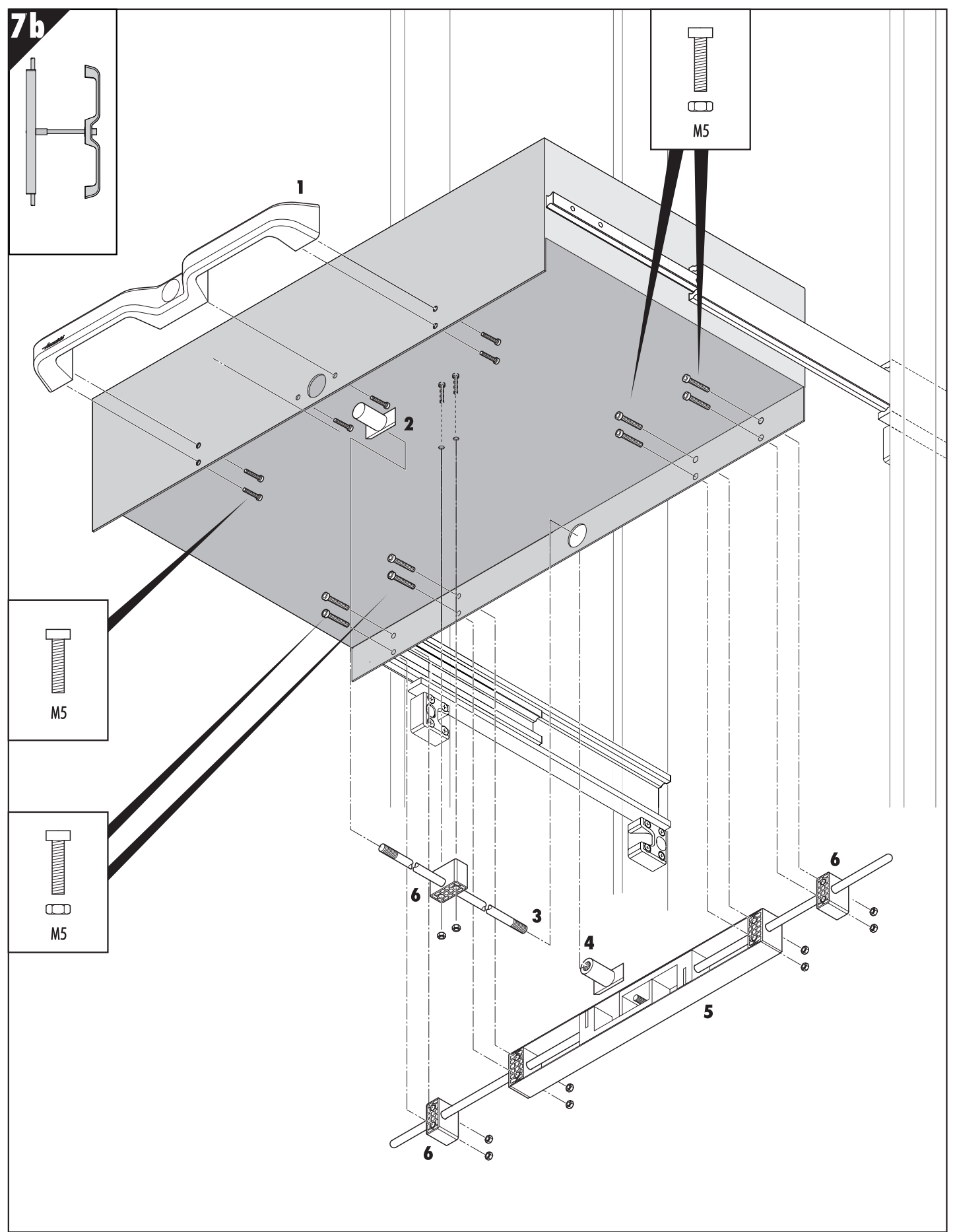

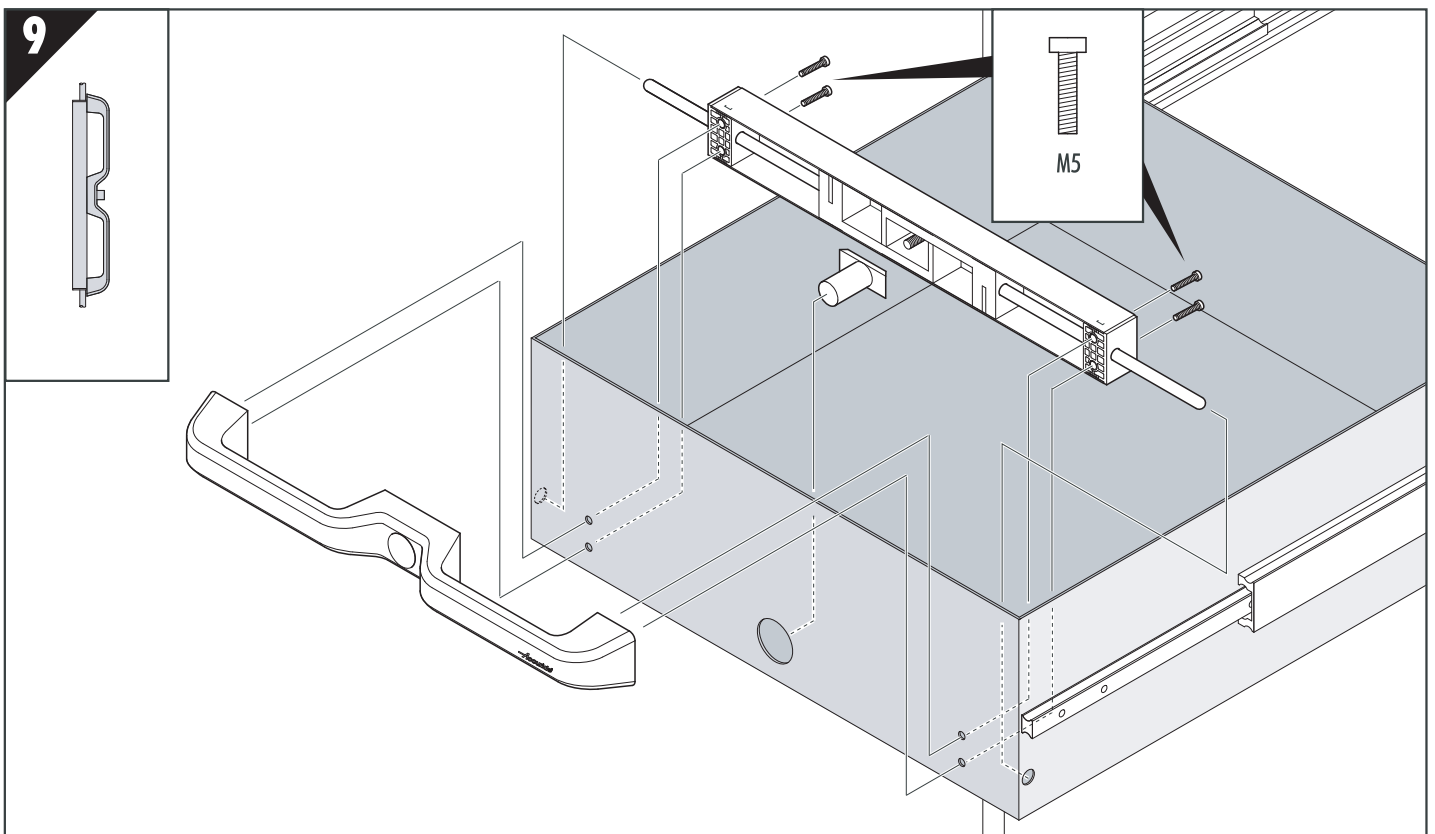
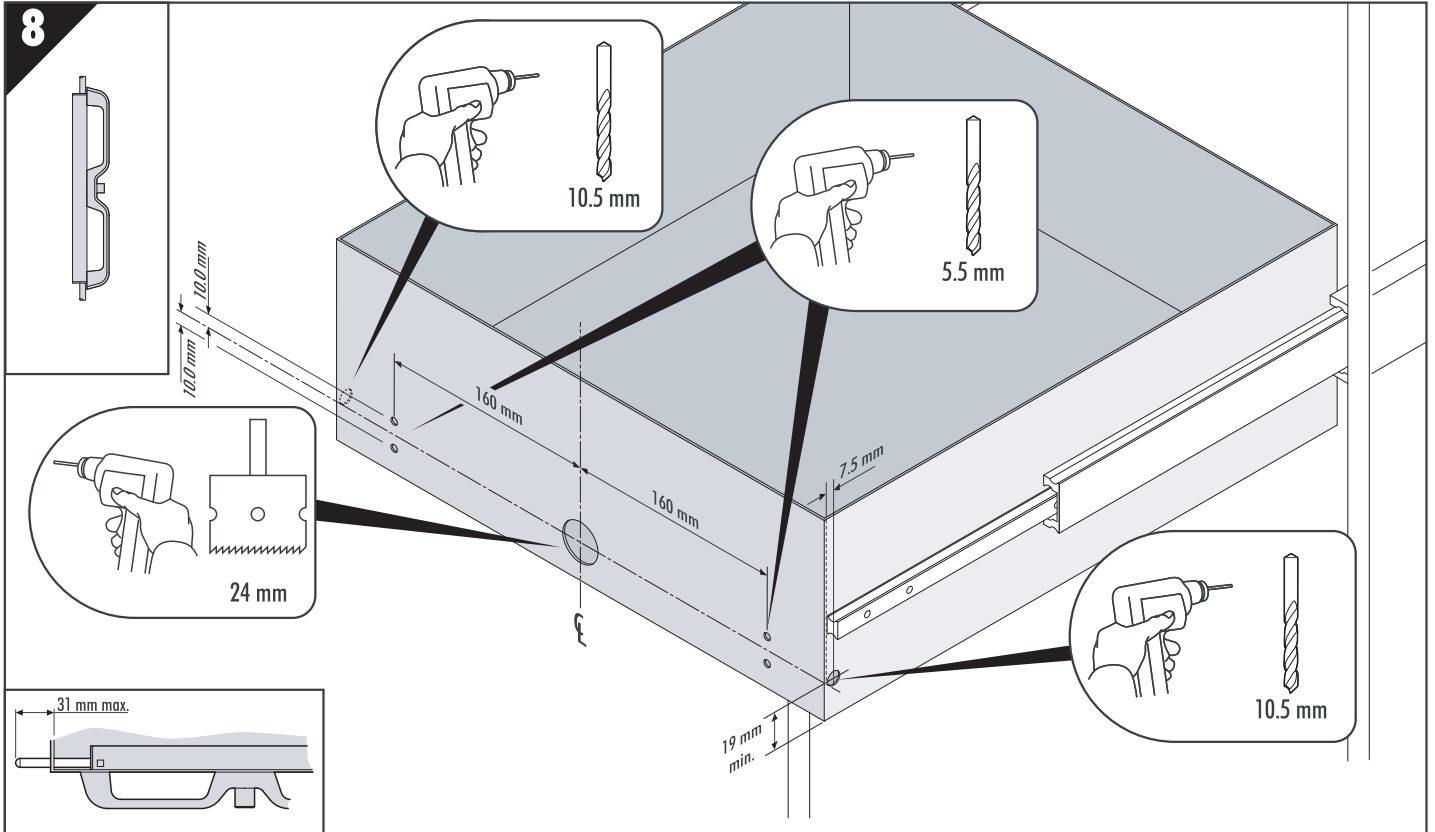
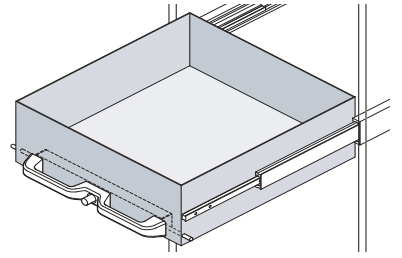

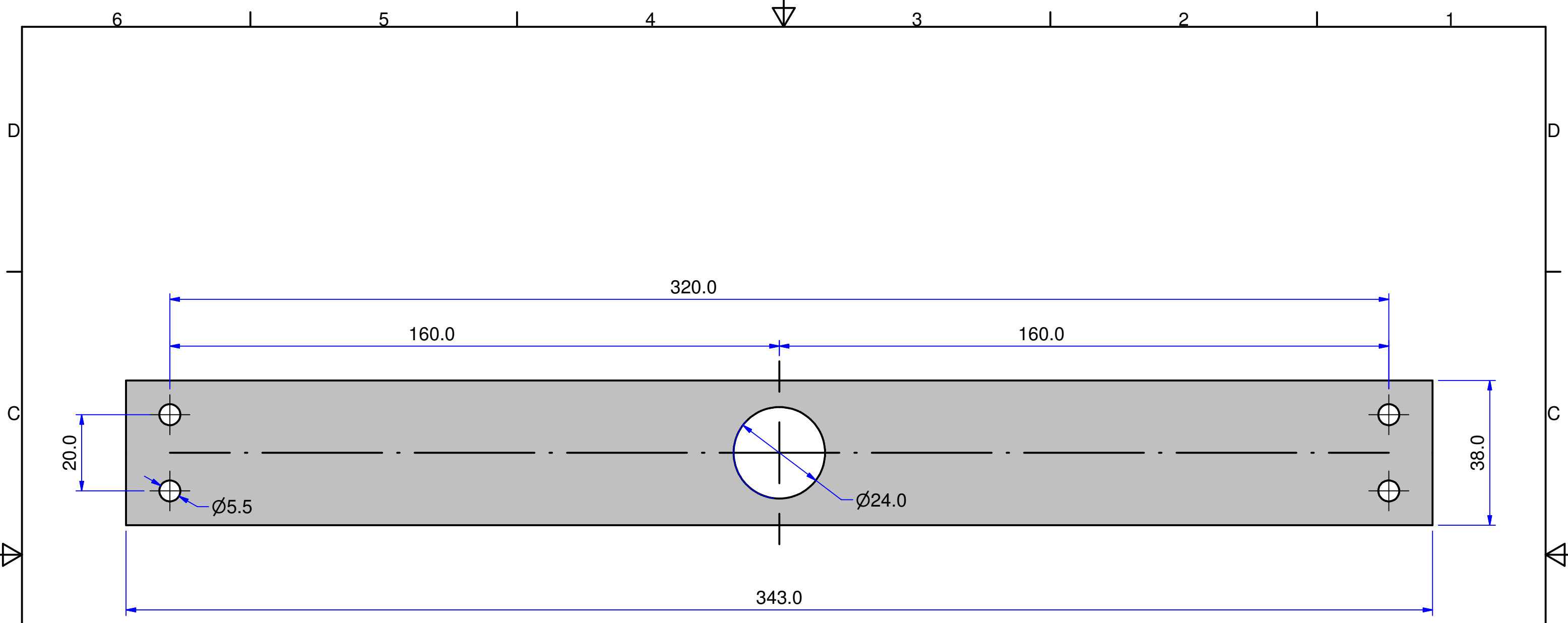

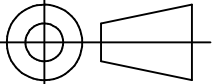

Hole drilling template for Accuride DBHAND handle

MATERIAL	PROJECT NUMBER	CUSTOMER		ALL DIMENSIONS ARE IN MILLIMETERS UOS ELECTRONIC DATA IS MASTER DO NOT SCALE	 3rd ANGLE PROJECTION	
	FINISH	DATE DRAWN	BY			CHECKED
OR AGREED EQUIVALENT	TOLERANCES (UOS)				TITLE	PAPER SIZE
	MASS	.X ± 0.2 .XX ± 0.10 ANGULAR ± 1° DIA. ± 0.1			LILIPUT ROAD - BRACKMILLS INDUSTRIAL ESTATE - NORTHAMPTON - NN4 7AS - UNITED KINGDOM - TEL. (+44)1604 761111 - FAX. (+44)1604 767190	
						PART NUMBER REVISION LEVEL SHEET 1 / 1