



# M3 Compression System

## Remote compression latch

- Consistent compression driven by rotational rod
- Adjustable grip
- Meets NEMA 4 / IP66 and EMI standards
- Can be driven by hand, tool or key-locking actuators

### Material and Finish

Zinc alloy and steel, zinc plated

### Performance Details

Max. static load:

890 N (200 lbf) per latch

Average ultimate load:

1335 N (300 lbf)

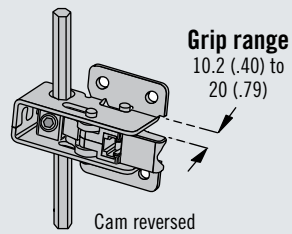
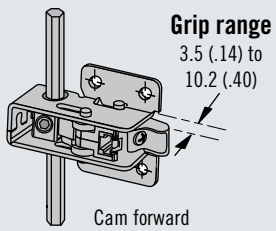

### Notes

Do not exceed 20 (.79) grip range with cam reversed

### Part Number

Remote compression latch and optional keeper only see table

The complete system consists of:  
Remote compression latch and / or optional keeper (see page 246)  
Actuator (see pages 247 - 250)  
Rods (see page 251)

Order each component separately

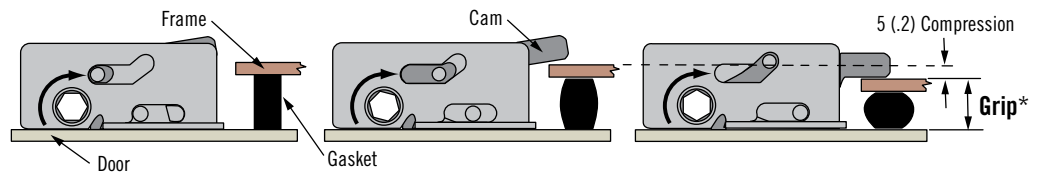
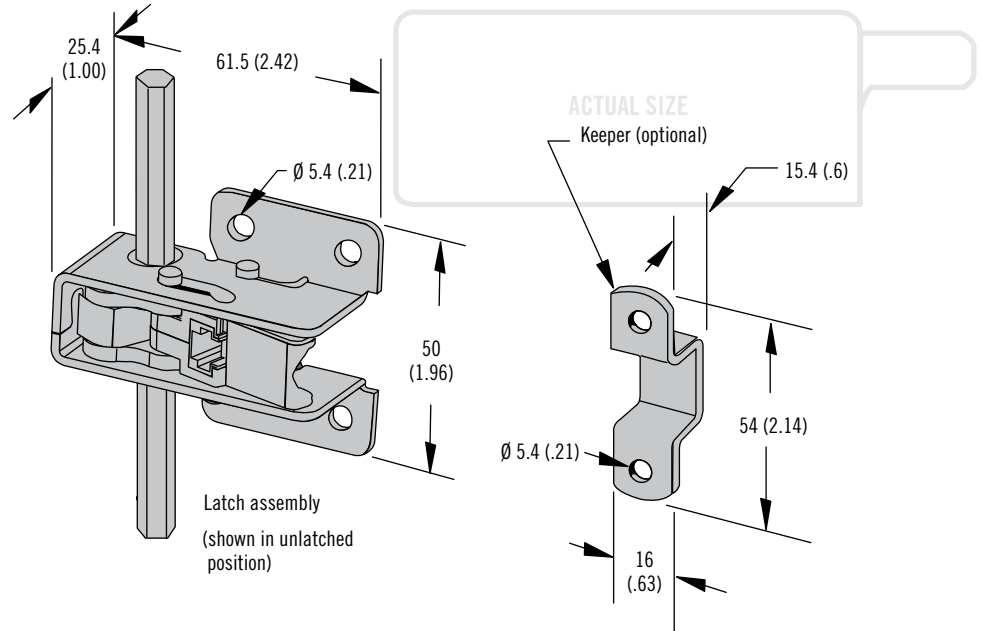

\* Measure your Grip from the latch mounting surface to the inside frame surface, with gasket compressed

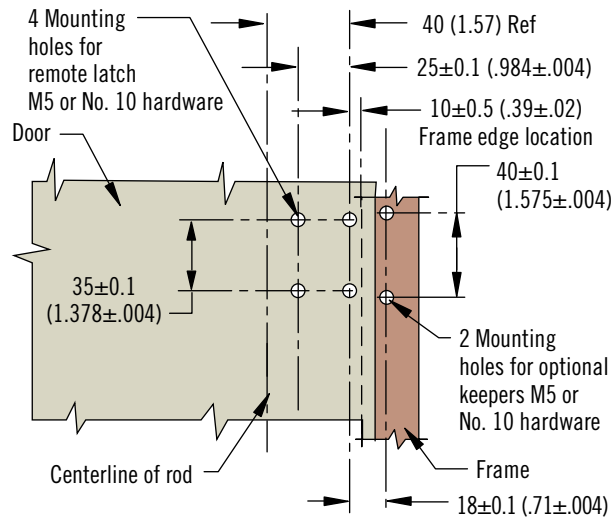

### Inside view

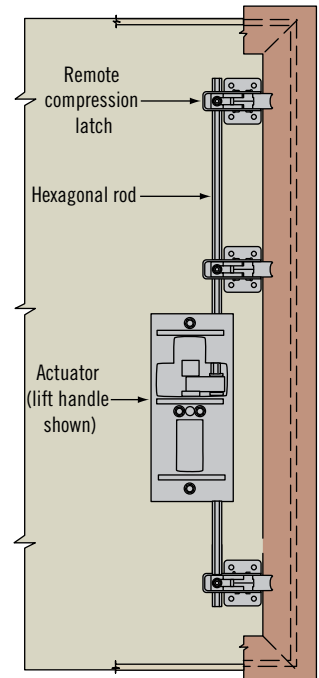

Part Number	
Remote compression latch	M3-50
Keeper (optional) use for grip ranges 15 - 30 (.59 - 1.18)	M3-51

Dimensions in millimeters (inch) unless otherwise stated

# M3 Compression System

## Actuators · Lift handle



### Lift Handle

Locking options

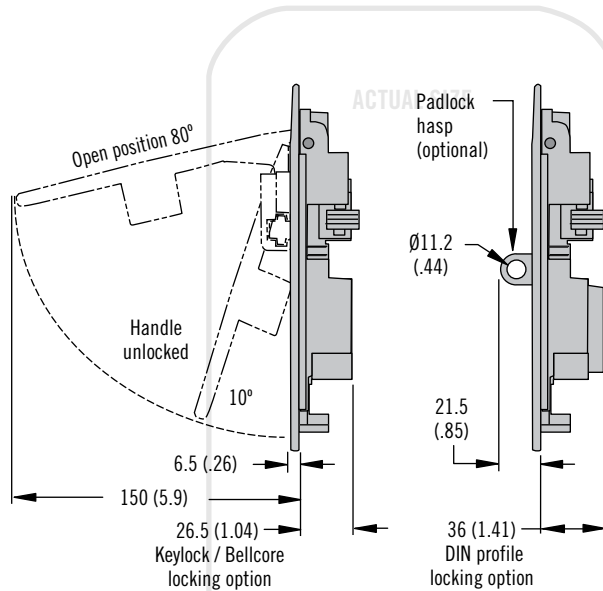
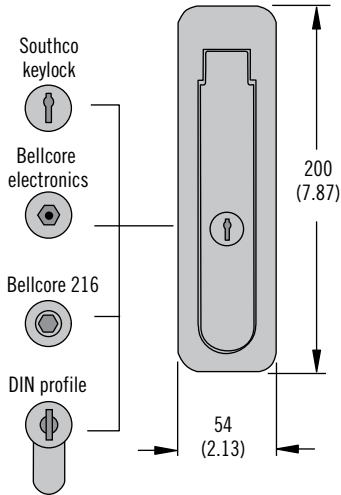

- Suitable for left and right side latching
- Meets NEMA 4/ IP66, GR487 and EMI standards
- Ejecting handle

### Material and Finish

Zinc alloy black powder coated and steel, zinc plated

### Sealing Notes

NEMA 4 / IP66 achieved using gasket supplied

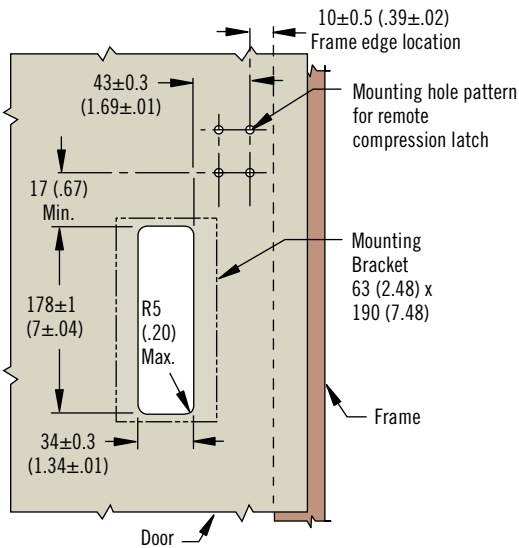

### Part Number Selection

Actuator only

The complete system consists of:  
 Remote compression latch and / or optional keeper (see page 246)  
 Actuator (see pages 247 - 250)  
 Rods (see page 251)  
 Order each component separately

**P** Padlock option  
 0 Non padlock  
 1 Padlockable

**D** Door thickness range  
 10 1.5 - 3 (.06 - .12)  
 11 3 - 4.5 (.12 - .18)  
 25 24 - 25.5 (.94 - 1.0)

**L** Lock style  
 10 Key-locking keyed alike CH751 (two keys supplied)  
 11 DIN profile supplied keyed alike 347876 (three keys supplied)  
 16 Bellcore 216  
 17 Bellcore electronics

**M3 - 40 - L P - D**



# M3 Compression System

## Actuators · Push-button handle

- Suitable for left and right side latching

### Material and Finish

Zinc alloy black powder coated and steel, zinc plated

### Sealing Notes

NEMA 4 / IP66 achieved using optional gaskets (ordered separately)

### Push-Button Handle

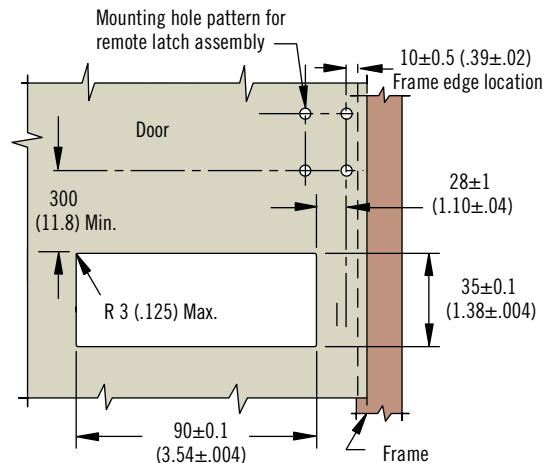
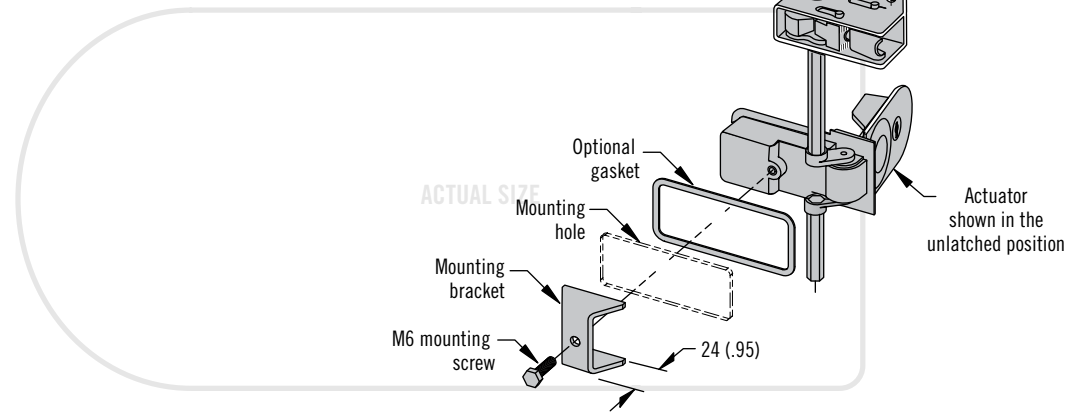
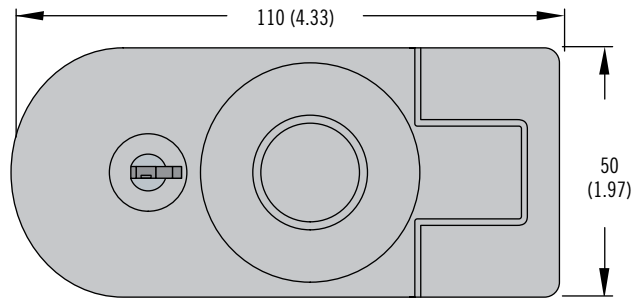

### Part Number

Actuator and sealing gasket only see table

The complete system consists of:  
Remote compression latch and / or optional keeper (see page 246)  
Actuator (see pages 247 - 250)  
Rods (see page 251)

Order each component separately

Actuator	Door Thickness Range	Part Number
Push-button handle	0 - 5 (0 - .20)	M3-90
	5 - 10 (.20 - .39)	M3-92
Push-button handle with key-lock	0 - 5 (0 - .20)	M3-91
	5 - 10 (.20 - .39)	M3-93

### Sealing Gasket Part Number

C5-82



[www.southco.com/M3](http://www.southco.com/M3)

Dimensions in millimeters (inch) unless otherwise stated

**southco**  
CONNECT · CREATE · INNOVATE

# M3 Compression System

## Actuators · Paddle handle



### Paddle Handle

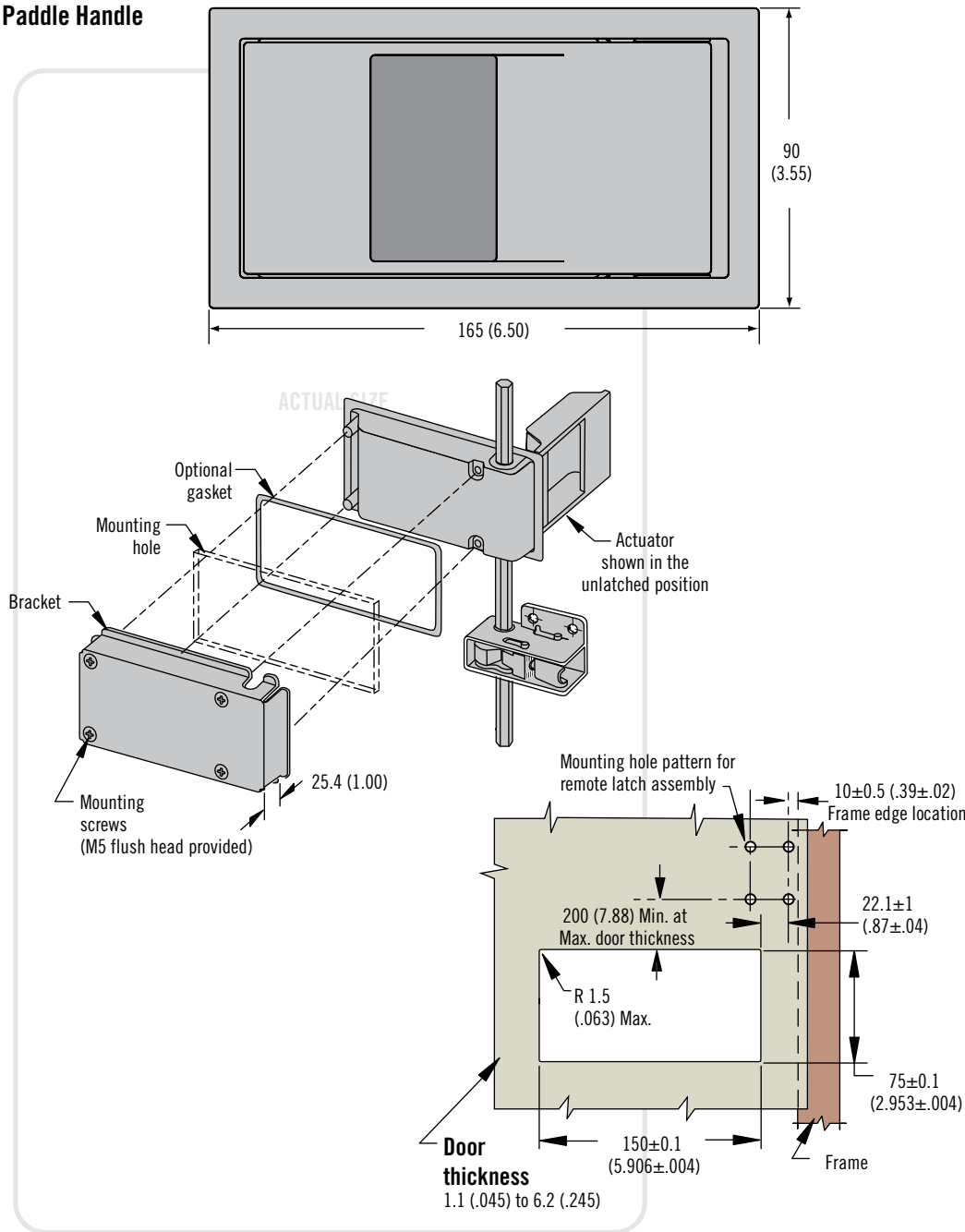

- Suitable for left and right side latching

### Material and Finish

Zinc alloy black powder coated and steel, zinc plated

### Sealing Notes

NEMA 4 / IP66 achieved using gasket supplied



Actuator	Part Number
Paddle (includes bracket and screws)	M3-10
Paddle with key-lock (includes bracket and screws)	M3-17

Gasket Type	Part Number
Environmental	M3-12
EMC	M3-13

### Part Number

Actuator and gaskets only see table

The complete system consists of:  
 Remote compression latch and / or optional keeper (see page 246)  
 Actuator (see pages 247 - 250)  
 Rods (see page 251)

Order each component separately





# M3 Compression System

Actuators · Door edge lever · Concealed

- Simple actuator for top or bottom of door

### Material and Finish

Door edge lever: Zinc alloy black powder coated and steel, zinc plated  
 Adaptor: Zinc alloy, chemical protective film  
 Concealed: Zinc alloy, chemical protective film

### Notes

Concealed: Operated by 8mm hex wrench (not supplied)

### Door Edge Lever

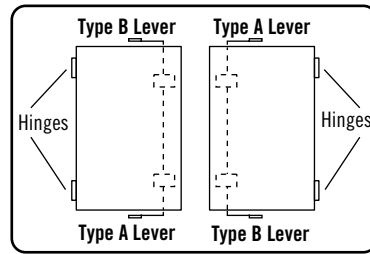
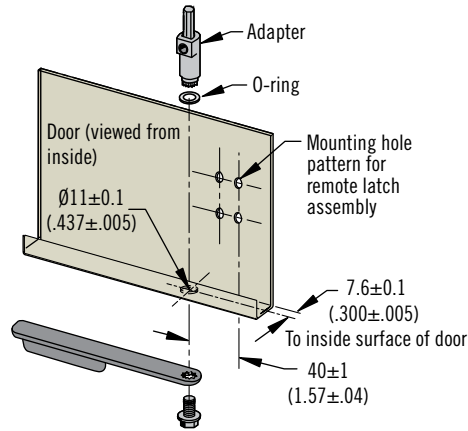
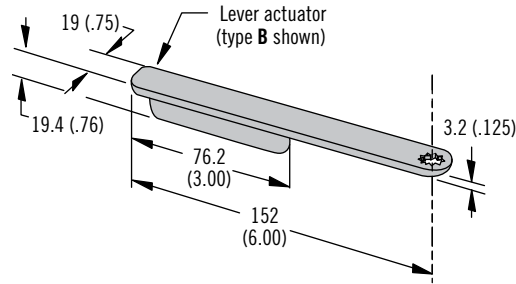

### Concealed

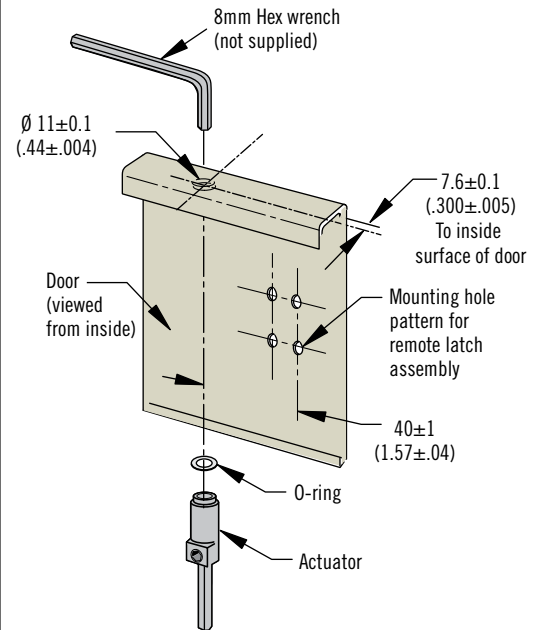
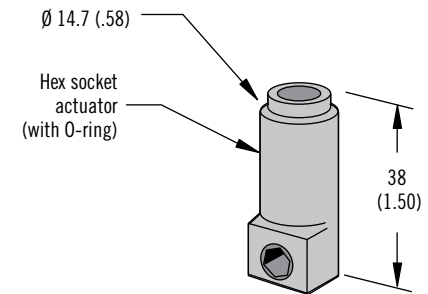

### Part Number

Actuator only see table

The complete system consists of:  
 Remote compression latch and / or optional keeper (see page 246)  
 Actuator (see pages 247 - 250)  
 Rods (see page 251)

Order each component separately

Actuator	Type	Part Number
Lever (includes adapter and O-ring)	A	M3-31
	B	M3-32

Actuator	Part Number
Hex socket with O-ring seal	M3-30

Dimensions in millimeters (inch) unless otherwise stated

# M3 Compression System

## Rods and Calculator



### Hexagonal Rod

Hex Rod Length		Part Number
Hex rods (length measured in centimeters)	125 cm	M3-125
	155 cm	M3-155
	185 cm	M3-185

### Material and Finish

Stainless steel, natural

### Notes

If you choose to use your own rods, they should have no more than 1 degree of twist in any meter length

### Part Number

Rod only see table

The complete system consists of:  
Remote compression latch and / or optional keeper (see page 246)  
Actuator (see pages 247 - 250)  
Rods (see page 251)

Order each component separately

To Determine Rod Length Per Actuator		
For Lift and Paddle Handle	For Push-Button Handle	For Door Edge Lever and 8 mm Hex Socket
<ul style="list-style-type: none"> <li>Use center to center distance between farthest remote latches</li> <li>Add 2 cm</li> </ul>	<ul style="list-style-type: none"> <li>2 rods are required</li> <li>Use the distance from centerline of actuator to centerline of farthest latch assembly</li> <li>Top and bottom rods may be different length</li> </ul>	<ul style="list-style-type: none"> <li>Use the distance between the door edge and the centerline of the farthest latch</li> </ul>

### Calculation Notes

Once you have completed the calculation please order the following parts:

- 1 x Actuator
- 1 or 2 rods to correct length
- Number of compression latches determined from calculation

### Calculator

To determine the minimum number of remote compression latches you require along the door edge:

$$N = \frac{L \times R}{470}$$

N = Number of compression latches along door edge (rounded to the nearest whole number)  
 L = Total length of gasketing material in millimeters  
 R = Gasket compression rate in N / mm

**Example:**  $\frac{5200 \text{ mm} \times 0.3 \text{ N / mm}}{470} = 3.28 = 3 \text{ latches}$

Remote compression latches should be evenly spaced along edge of door