



V7 Draw Latch

Over-center · Large · Stainless steel

- Sleek, smooth low profile design
- Locking and non-locking
- Robust, riveted, tamper-resistant construction

Material and Finish

316 Grade stainless steel
electropolished

Performance Details

Max. working load: 1200 N (270 lbf)

Installation Notes

Install assembly with six M3 (No. 4) flat head screws (not supplied)

Keys

Overmolded key S008 (pair)
Part number: M1-525-39-S008

Latch

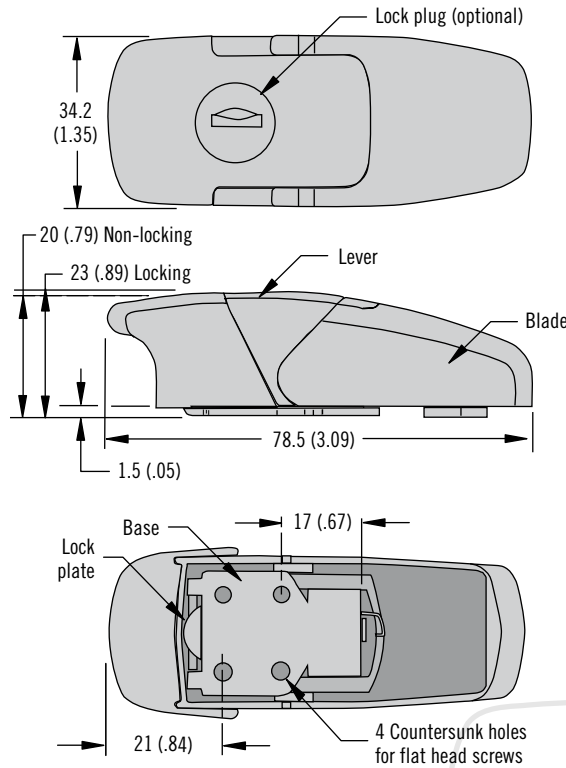

Keeper

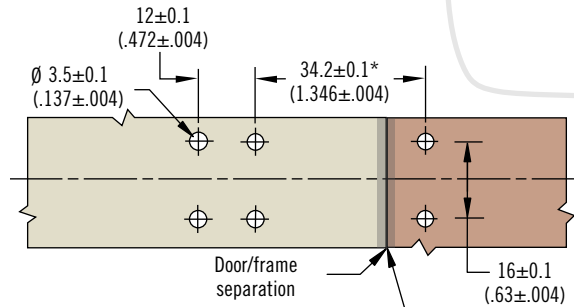
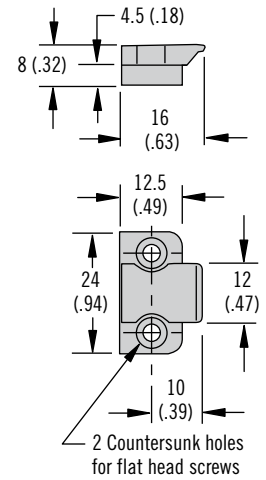

*Gasket recommended to accommodate panel variations

ACTUAL SIZE

Part Number

See table

Assembly complete with keeper

| Description | Part Number |
|--|--------------|
| Non-locking | V7-20-101-24 |
| Locking keyed alike S008 (2 keys supplied) | V7-20-111-24 |

V7 Draw Latch

Over-center · Large and small · Zinc alloy



Latch Large

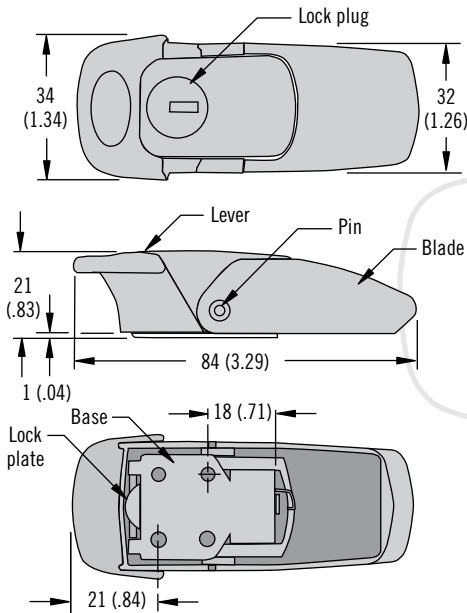

Keeper

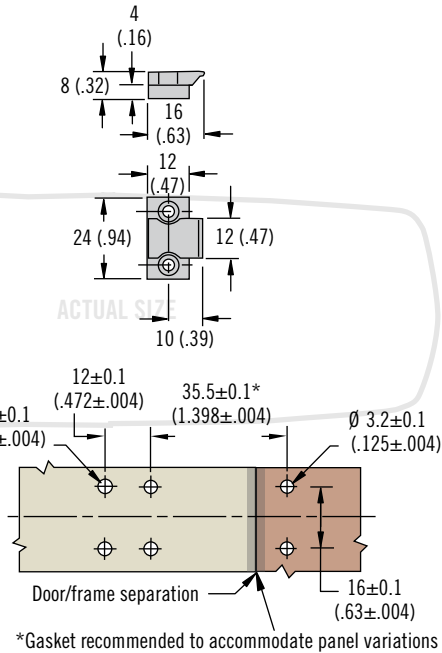

Latch Small

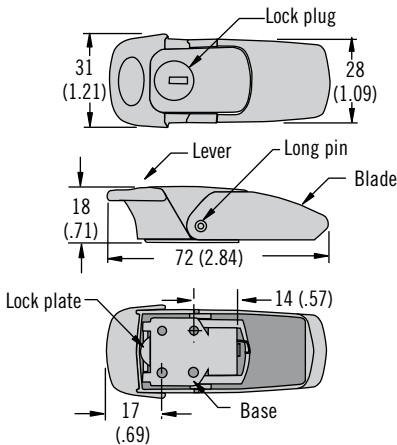

Keeper

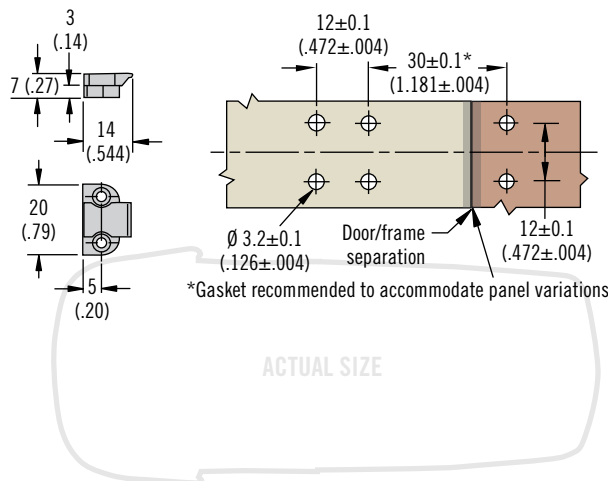

- Sleek, smooth low profile design
- Locking and non-locking
- Robust, riveted, tamper-resistant construction

Material and Finish

Zinc alloy, chrome plated or powder coated and stainless steel

Performance Details

Max. working load:
1200 N (270 lbf)

Installation Notes

Install assembly with six M3 (No. 4) flat head screws (not supplied)

Keys

Key S010 (pair)
Part number: V7-KEYS

B Base type

- 10 Small
- 20 Large

F Finish

- 10 Bright chrome plated
- 20 Satin chrome plated
- 50 Black powder coated

V7 - B - 1 L - F

L Lock style

- 01 Large non-locking
- 05 Small non-locking
- 11 Large locking keyed alike S010 (2 keys supplied)
- 15 Small locking keyed alike S010 (2 keys supplied)

Part Number Selection

Assembly complete with keeper