

# LIFT-O-MAT®

## Brackets for gas springs and dampers Winkelbleche für Gasfedern und Dämpfer

Part No. / Bestell-Nr. **8262WE**  
 $F_{max}^* = 1000 \text{ N}$

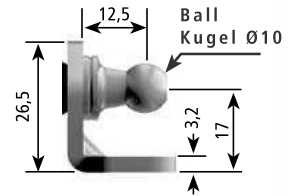
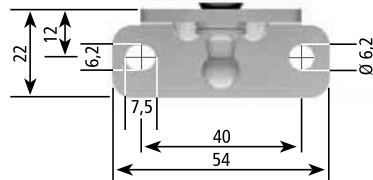

Part No. / Bestell-Nr. **8267WG**  
 $F_{max}^* = 700 \text{ N}$

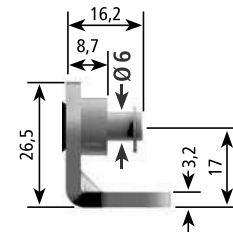
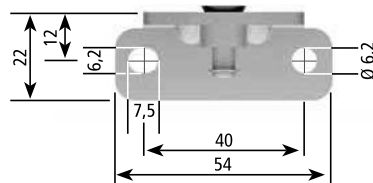

Part No. / Bestell-Nr. **8261WJ**  
 $F_{max}^* = 1000 \text{ N}$

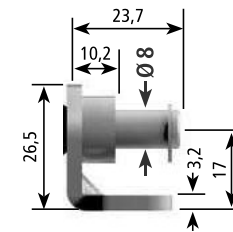
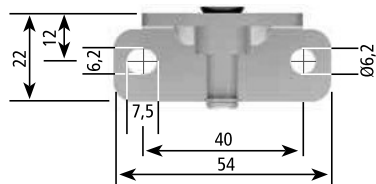

Part No. / Bestell-Nr. **8268WB**  
 $F_{max}^* = 700 \text{ N}$

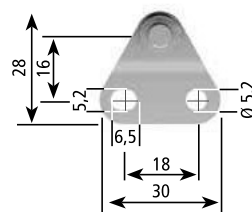

$F_{max}^*$  = Maximum allowable force at 20°C in compressed position. Material: steel, zinc-plated.  
 $F_{max}^*$  = Maximale zulässige Belastung bei 20°C in eingeschobener Position. Material: Stahl, verzinkt.

Part No. / Bestell-Nr. **8264WV**

F<sub>max</sub>\* = 1000 N

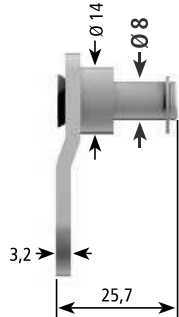
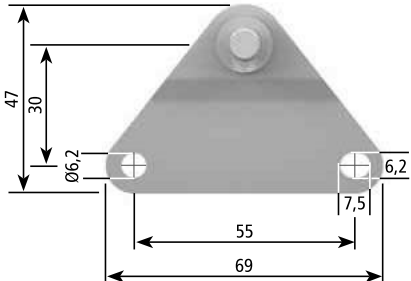
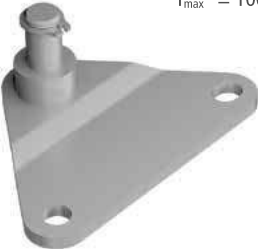

Part No. / Bestell-Nr. **8265WQ**

F<sub>max</sub>\* = 1000 N

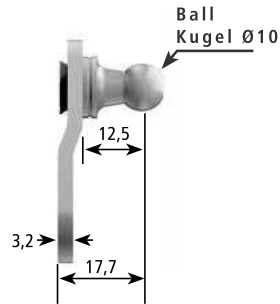
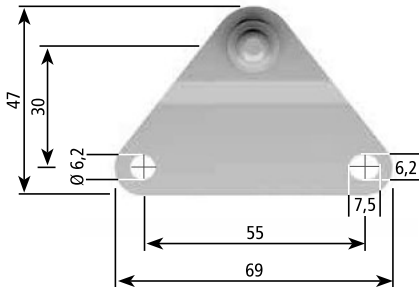

Part No. / Bestell-Nr. **023189**

F<sub>max</sub>\* = 700 N

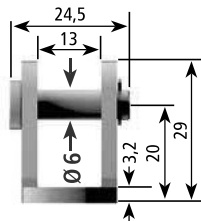
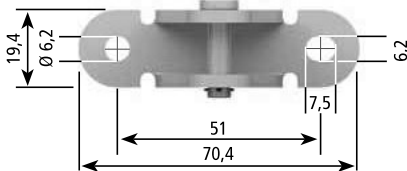
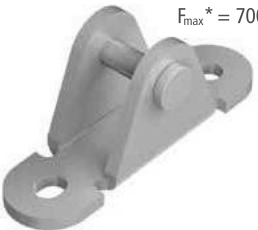

Part No. / Bestell-Nr. **023083**

F<sub>max</sub>\* = 1600 N

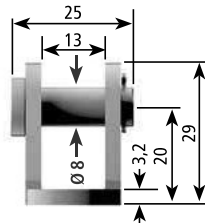
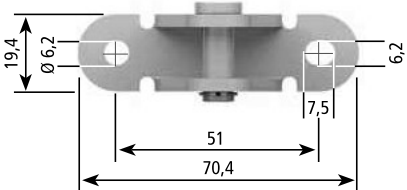

We reserve the right to make modifications. Dimensions in mm. Änderungen vorbehalten. Maßangaben in mm.

# LIFT-O-MAT®

## Brackets for gas springs and dampers Winkelbleche für Gasfedern und Dämpfer

Part No. / Bestell-Nr. **9222SJ**  
F<sub>max</sub>\* = 500 N

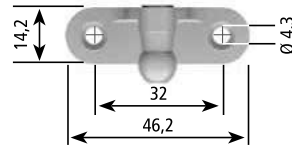

Part No. / Bestell-Nr. **7592TM**  
F<sub>max</sub>\* = 350 N

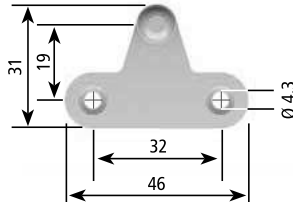

Part No. / Bestell-Nr. **6284UG**  
F<sub>max</sub>\* = 500 N

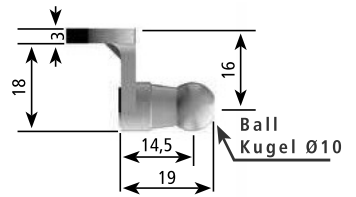
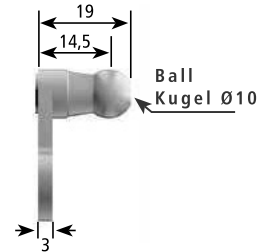
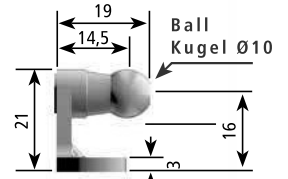
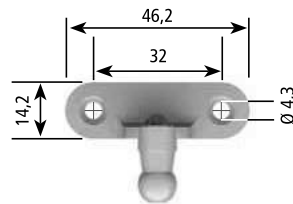

## Ball stud / Kugelzapfen

**4565BD**

Clear passivated / Klar passiviert

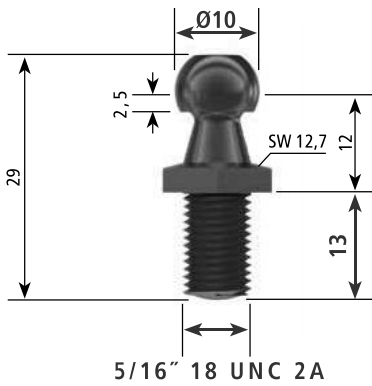

**4486MD**

Black passivated / Schwarz passiviert

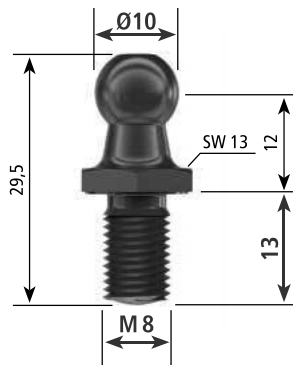

**177583**

Black passivated / Schwarz passiviert

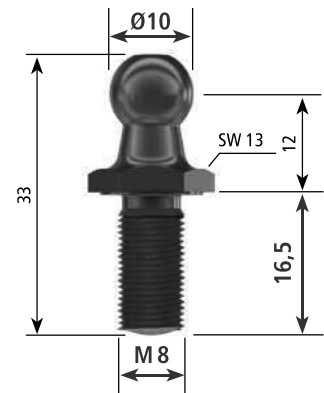

**8442LT**

Black passivated / Schwarz passiviert



**072796**

Black passivated / Schwarz passiviert

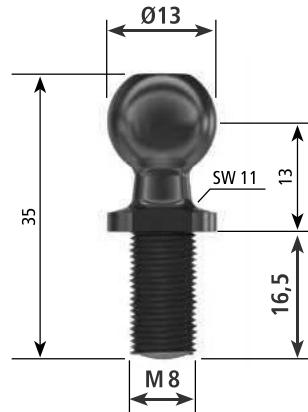

**2054QF**

Clear passivated / Klar passiviert

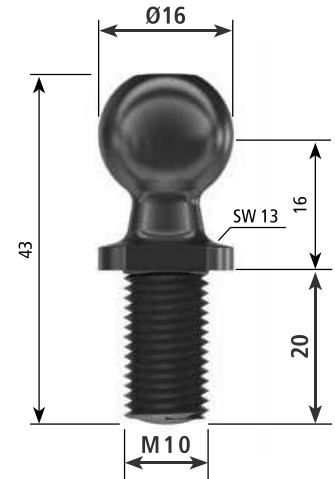

We reserve the right to make modifications. Dimensions in mm.  
Änderungen vorbehalten. Maßangaben in mm.