

## Horizontal Hold Down Action Clamp H - 235 Series

### FEATURES:

- Base: Flanged or straight
- Arm Type: Adjustable Arm
- Bar Opens: 85°
- Handle Opens: 60°



Model No.H-235-U

Model No.	Arm Type	Base Type
H-235-U	Adjustable Arm	Flanged
H-235-UB	Adjustable Arm	Straight

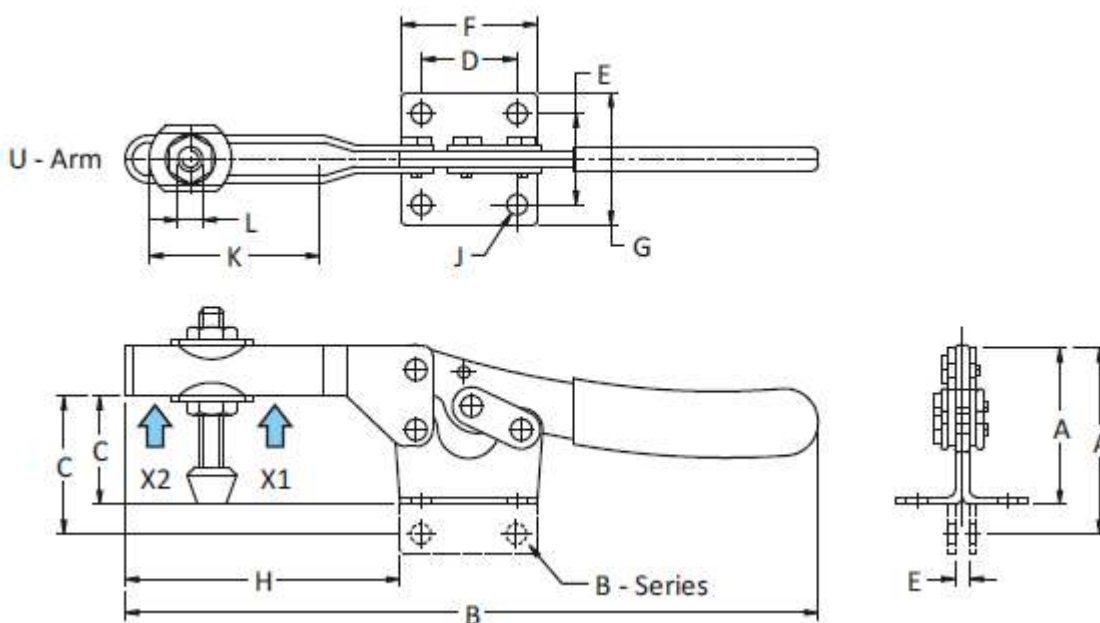

Model No.	Holding Capacity		Weight Kgs	Handle Moves	Bar Opens	Dimensions										
	X2	X1				A	B	C	D	E	F	G	H	J	K	L
H-235-U	1.30 kN	3.40 kN	0.560	60°	85°	68.0	290.0	45.0	41.4	41.4	57.2	57.2	113.0	8.5	70.0	M10 Bolt
H-235-UB	1.30 kN	3.40 kN	0.560	60°	85°	81.0	290.0	61.0	41.4	8.0	57.2	-	113.0	8.5	70.0	M10 Bolt