

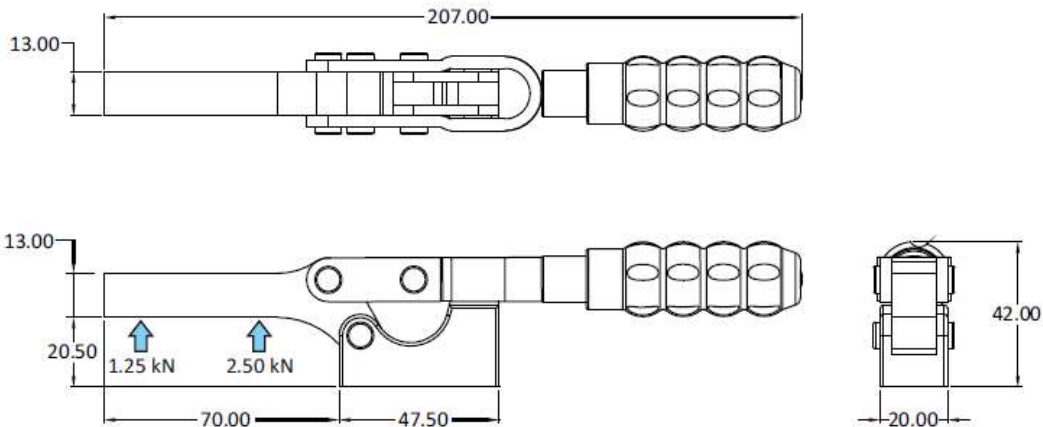

Horizontal Hold Down Action Clamps H - 5305 Series

Model No: H - 5305 - B/SB - HV

- Weight: 0.370 KG
- Handle Moves: 69°
- Bar Opens: 90°



Model No: H - 5305 - SB - HV

- Weight: 0.490 KG
- Handle Moves: 69°
- Bar Opens: 90°

