

Accuride®

MODEL 0363

Two-Way Travel Slide
Full Extension
Up to 100 lb. [45 kg.] Load Capacity**

Applications: Kitchen islands, pass-through shelves, and medical carts. Use Model 0363 wherever full access is needed from both sides of the installation. **This product is covered by U.S. and various foreign patents issued and/or pending.**

0363

QUICK REFERENCE

Full Extension Two-Way Travel
Lengths: 12"-24" & 28"
Load Rating: Up to 100 lbs [45 kg.]
Height: 1.43" [36.4]
Side Space: .85" [21.6]

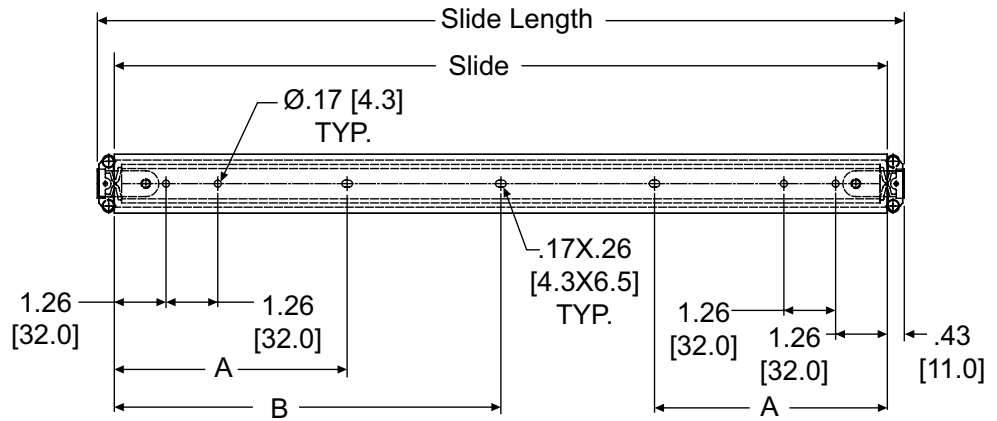
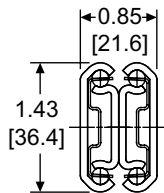
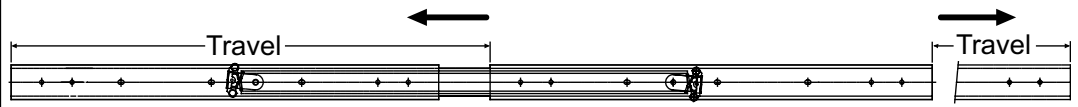
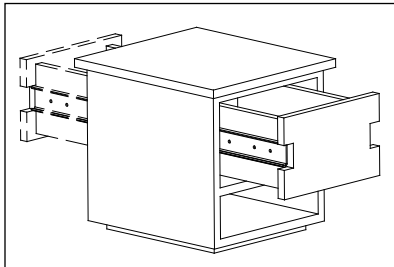

INCHES
[mm]

- Finish** Bright electro-zinc (C) (RoHS Compliant)
- Length** 12" - 24" & 28" [300 mm - 600 mm & 700 mm]
- Height** 1.43" [36.4 mm]
- Travel** Two-way travel, full extension
- Load** 100 lbs.** [45 kg] per pair
- Also** Center detent, non disconnect
- Hardware** Not included

Part Number	Slide Length	Slide	Travel	Travel X 2	A	B	Slide Weight	Load Rating
C0363-12	11.81 [300]	10.94 [278]	13.07 [332]	26.14 [664]	-	5.47 [139]	3.4 [1.54]	77 [35]
C0363-14	13.78 [350]	12.91 [328]	15.12 [384]	30.24 [768]	5.67 [144]	-	4.0 [1.81]	88 [40]
C0363-16	15.75 [400]	14.88 [378]	17.00 [432]	34.00 [864]	5.67 [144]	-	4.6 [2.08]	88 [40]
C0363-18	17.72 [450]	16.85 [428]	19.05 [484]	38.11 [968]	5.67 [144]	-	5.2 [2.35]	100 [45]
C0363-20	19.69 [500]	18.82 [478]	21.00 [532]	42.00 [1064]	5.67 [144]	-	5.8 [2.63]	100 [45]
C0363-22	21.65 [550]	20.78 [528]	22.99 [584]	45.98 [1168]	5.67 [144]	-	6.4 [2.89]	100 [45]
C0363-24	23.62 [600]	22.76 [578]	25.00 [632]	50.00 [1264]	5.67 [144]	-	6.9 [3.14]	100 [45]
C0363-28	27.55 [700]	26.69 [678]	29.00 [732]	58.00 [1464]	6.93 [176]	13.35 [339]	8.1 [3.70]	88 [40]

** Load rating based on 80,000 cycles.

Mounting Instructions

NOTE: The centerline for the cabinet member holes should be a minimum of .95" [24 mm] from the bottom of the cabinet opening (figure 1).

1. Pre-drill the holes for the cabinet member (figure 3). Install the slide outer members (larger member) to the cabinet using #8 pan head screws (figure 4). Make sure slides are parallel.
2. Pre-drill holes for drawer member (figure 5). Install drawer member using #8 screws (not included). Do not tighten screws at this time. Cycle drawer at least twice in both directions to allow drawer to self adjust. Tighten all screws (See figure 5 and 5a). There should be no sign of stiffness or binding.

NOTE: If drawer fronts are required, they must be notched to clear the stationary member of the slide. See figure 2.

For maximum load capacity use all mounting holes (figure 5b).

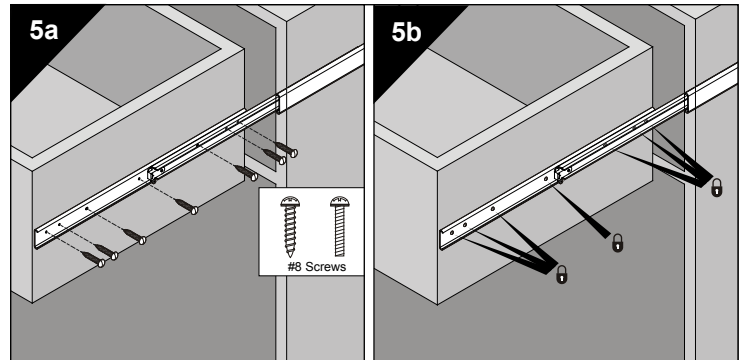
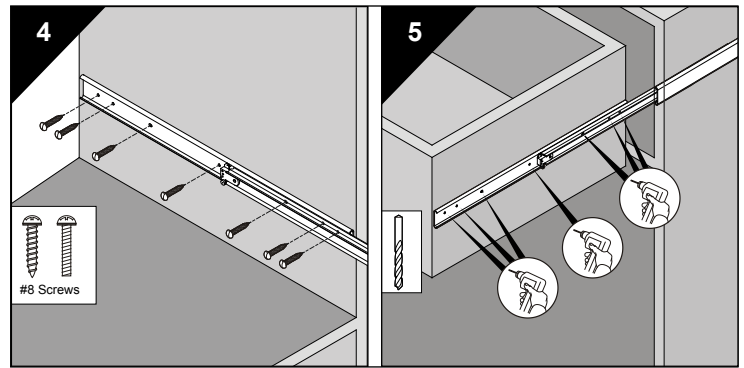
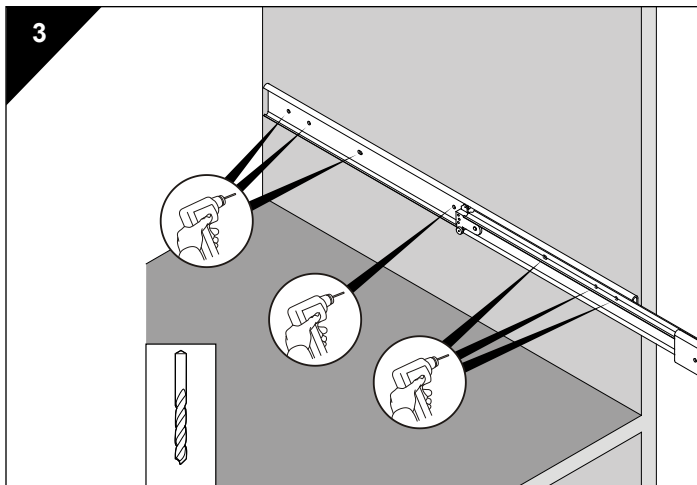
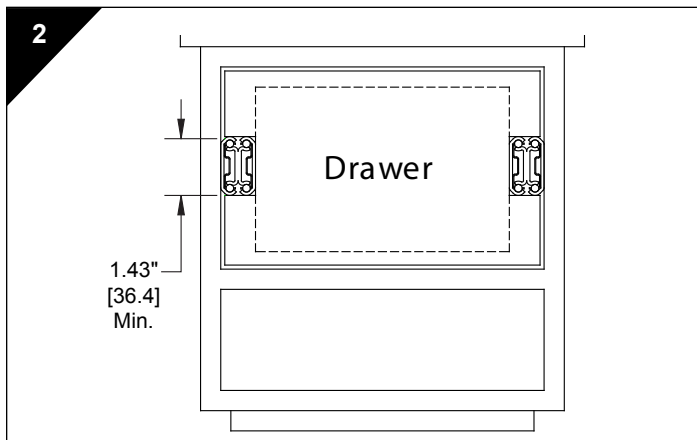
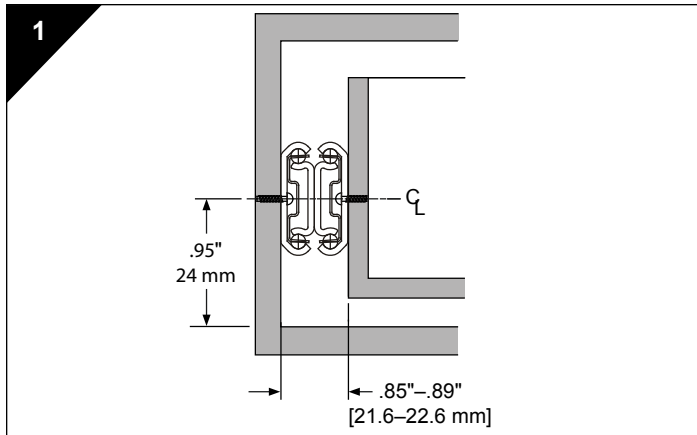

Slide Ordering Instructions

Complete your order for Accuride Model 0363 Two-Way Travel drawer slide by specifying the following:

Total Required Slides _____ 20 Each C 0363 -12
 Slide Finish _____
 Slide Model _____
 Slide Length _____

Packaging

Bulk Pack: Box quantities varies by length.
 Hardware not included.

Specifications

Slide members and ball retainers: Cold rolled steel

Ball bearings: Carburized steel

RoHS Compliant

NOTE: Specifications, materials, prices, terms, and delivery are subject to change without notice.

Accuride

ACCURIDE INTERNATIONAL INC.

12311 Shoemaker Avenue
 Santa Fe Springs, CA 90670

TEL (562) 903-0200

FAX (562) 903-0208

www.accuride.com

Manufacturing, Engineering, and Sales

United States • Germany • Japan • Mexico • United Kingdom • China

Copyright © 2018 Accuride International Inc. 3700-9531(1220)-MK137-R1-0318

For the most current technical information visit www.accuride.com