

## Steel-Smith Spring Loaded Latch Clamps

PAH - CT - 0120

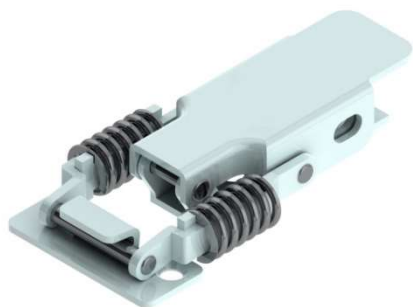

Also Available  
in Stainless Steel

PAH - CS - 0120 - SS

PAH - CS - 0130 - SS

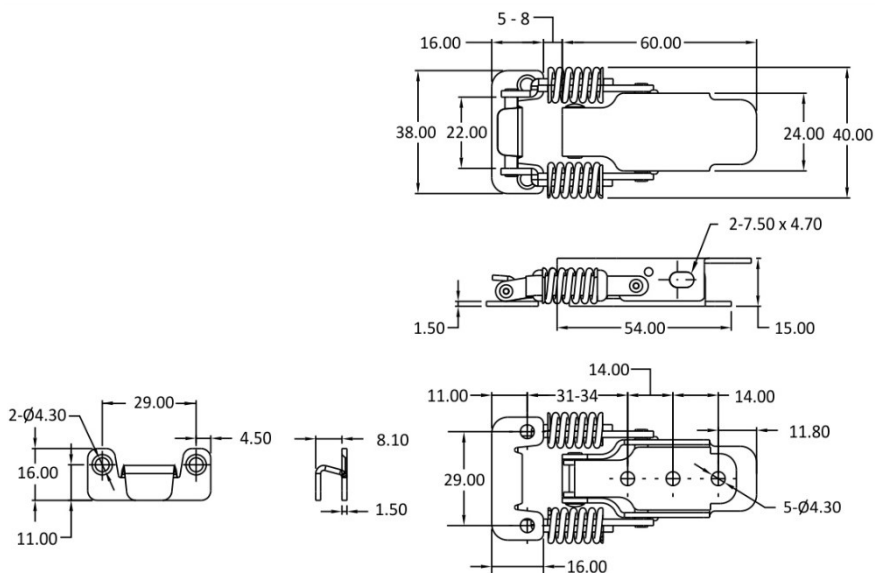

Model No.	Holding Capacity	Weight Kgs	Dimensions																	
			L1	L2	L3	L4	L5	L6	W1	W2	W3	W4	H	T	P1	P2	P3	P4	D	A x B
PAH - CT - 0120	0.50 kN	0.070	60	16	5-8	54	11.8	11	24	38	40	22	15	1.5	31-34	14	14	29	4.3	7.5 x 4.7
PAH - CT - 0130	0.50 kN	0.140	80	19	6-9	68.5	18.5	13	32	50	50	28	18	2.0	38-41	18	18	38	5.3	10 x 6.5

PAH - CT - 0130

