

Steel-Smith Latch Clamps – Heavy Duty PAH-30 Series – Rounded Hasp

Model No: PAH-30-602

Holding Capacity - 4.40 kN

Weight - 0.070 kgs

In Stainless Steel: PAH-30-602-SS

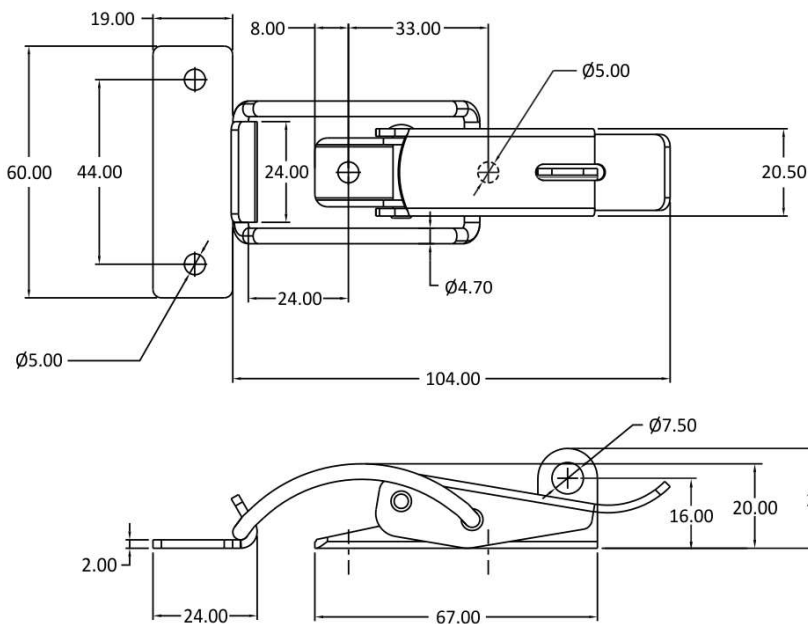
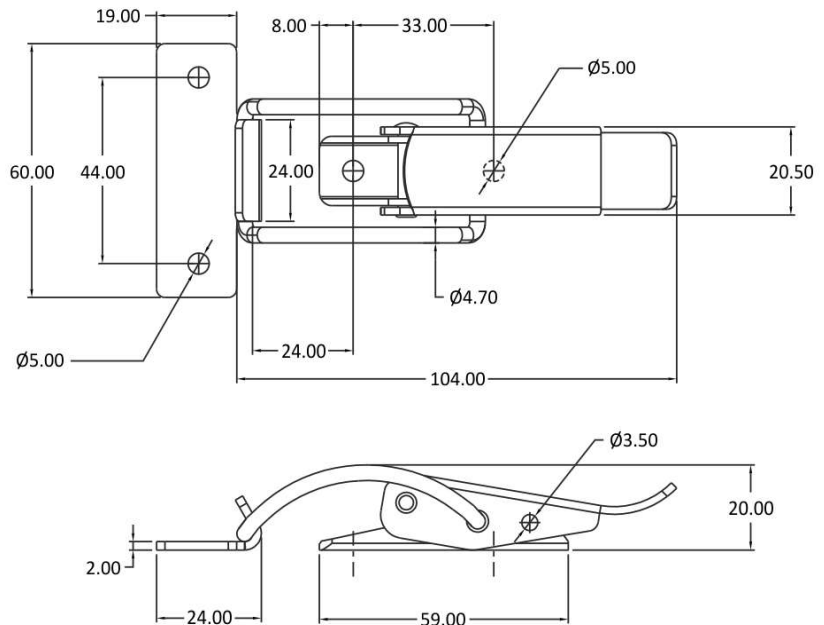

Model No: PAH-30-670

Holding Capacity - 4.40 kN

Weight - 0.078 kgs

In Stainless Steel: PAH-30-670-SS



www.conceptlatch.com.au

sales@conceptlatch.com.au

03 9388 2551



Concept Latch Lock & Hinge

Model No: PAH-30-625

Holding Capacity - 4.40 kN

Weight - 0.065 kgs

In Stainless Steel: PAH-30-625-SS

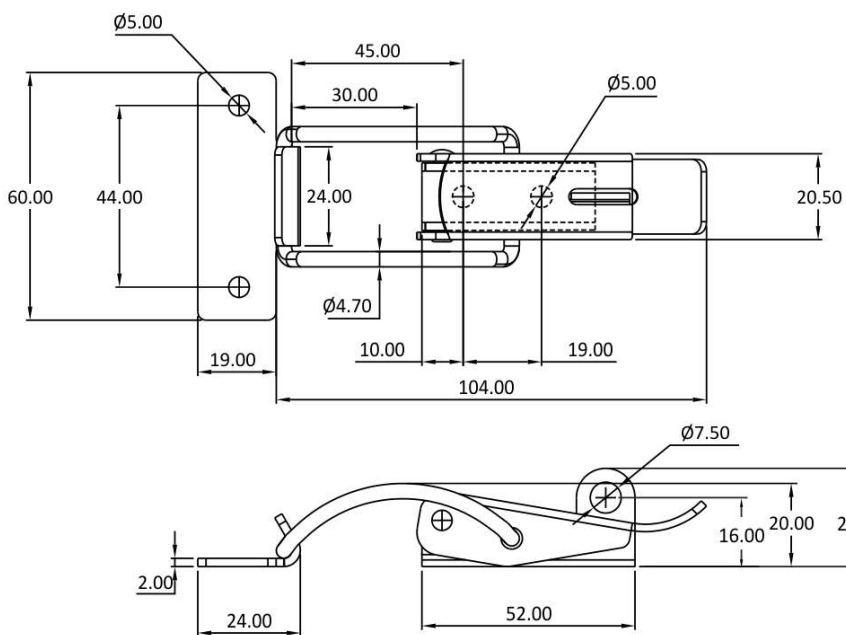
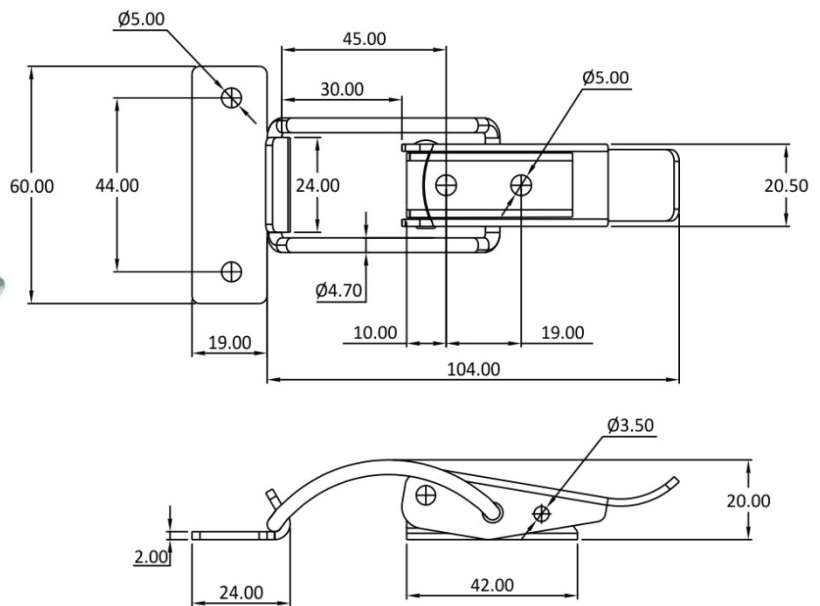

Model No: PAH-30-675

Holding Capacity - 4.40 kN

Weight - 0.070 kgs

In Stainless Steel:

PAH-30-675-SS

www.conceptlatch.com.au

sales@conceptlatch.com.au

03 9388 2551