

Steel-Smith Latch Clamps - Mini

Model No: PAH-CT-10103

Holding Capacity: 0.25 kN

Weight: 0.024 kgs

In Stainless Steel: PAH-CS-10103-SS

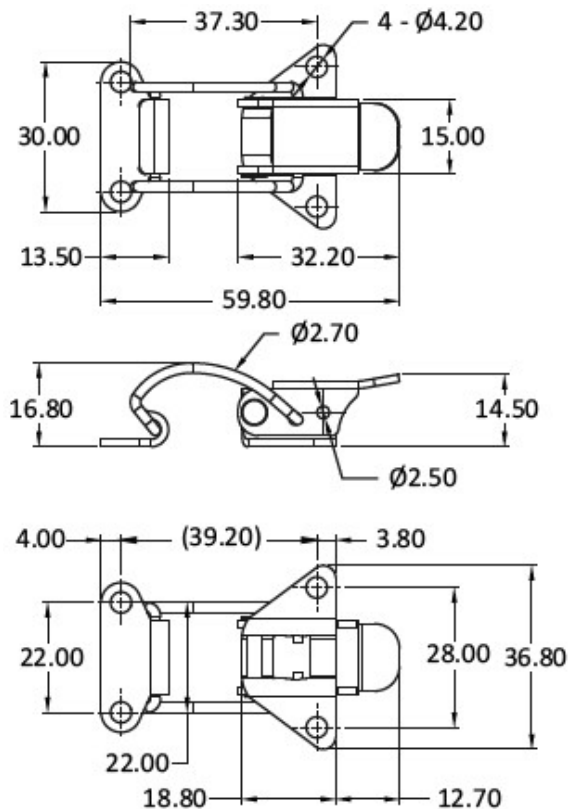
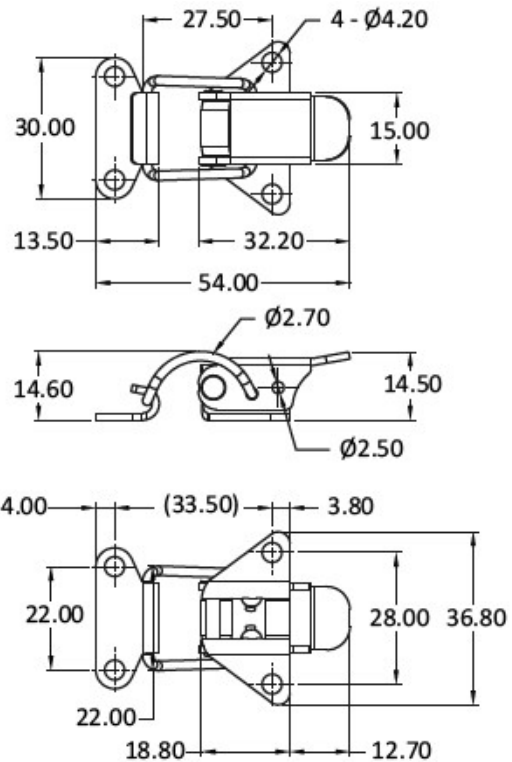

Model No: PAH-CT-10104

Holding Capacity: 0.25 kN

Weight: 0.026 kgs

In Stainless Steel: PAH-CS-10104-SS



Model No: PAH-CT-10105

Holding Capacity: 0.25 kN

Weight: 0.028 kgs

In Stainless Steel: PAH-CS-10105-SS

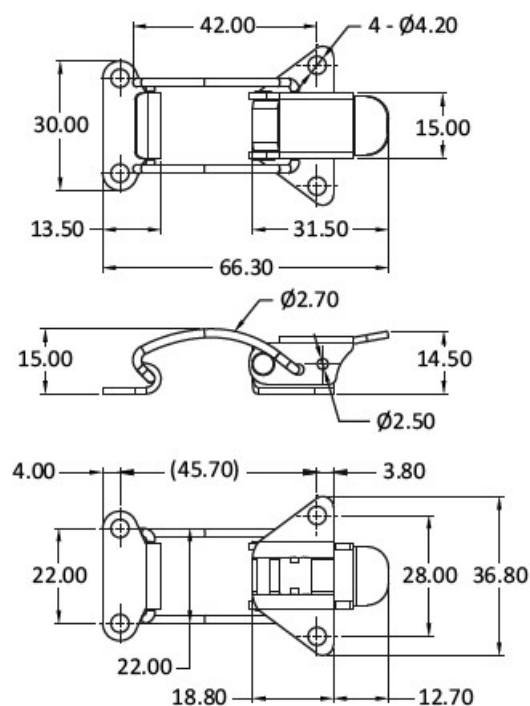

Model No: PAH-CT-1113

Holding Capacity: 0.20 kN

Weight: 0.025 kgs

In Stainless Steel: PAH-CS-1113-SS

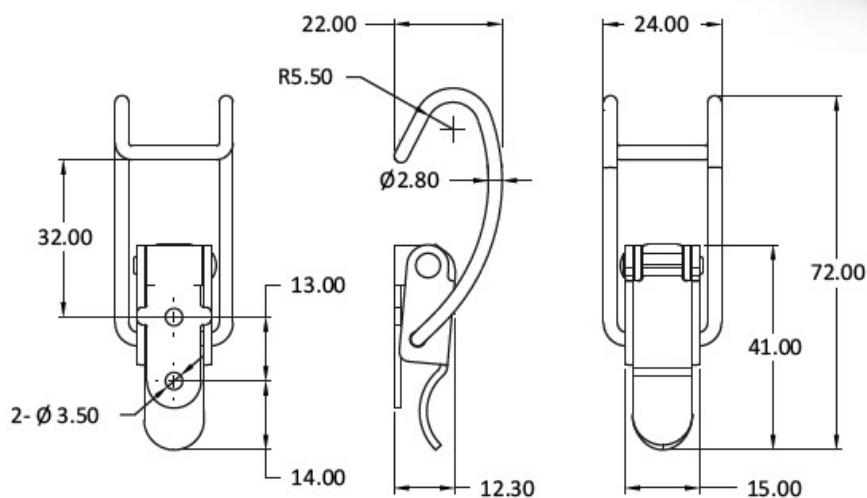

www.conceptlatch.com.au

sales@conceptlatch.com.au

03 9388 2551

Keepers Both Suitable for Model Numbers:

PAH-0313

PAH -4813

PAH - CT-10103

PAH - CT-10104

PAH - CT-10105

Model No: FH-02-531

Weight - 0.002 kgs

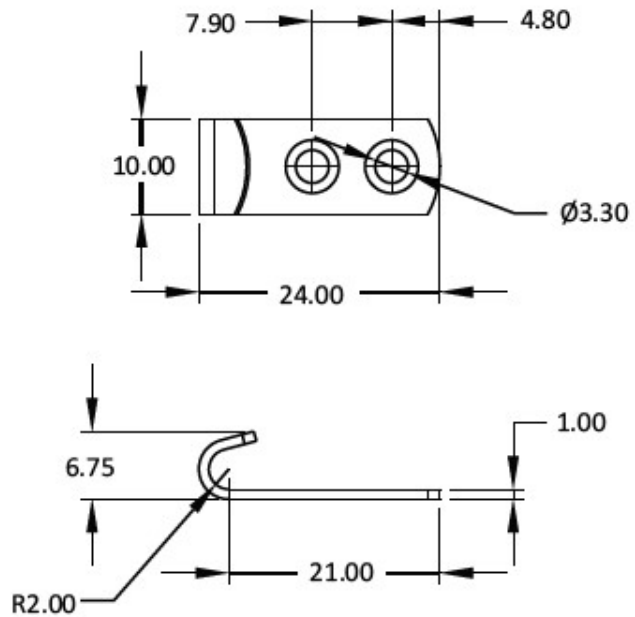

Model No: FH-03-613

Weight - 0.030 kgs

