

Steel-Smith Latch Clamps PAH- 60 & 70 Series – Hook Latch

Model No: PAH-60-2600

Holding Capacity: 2.90 kN

Weight: 0.150 kgs

In Stainless Steel: PAH-60-2600-SS

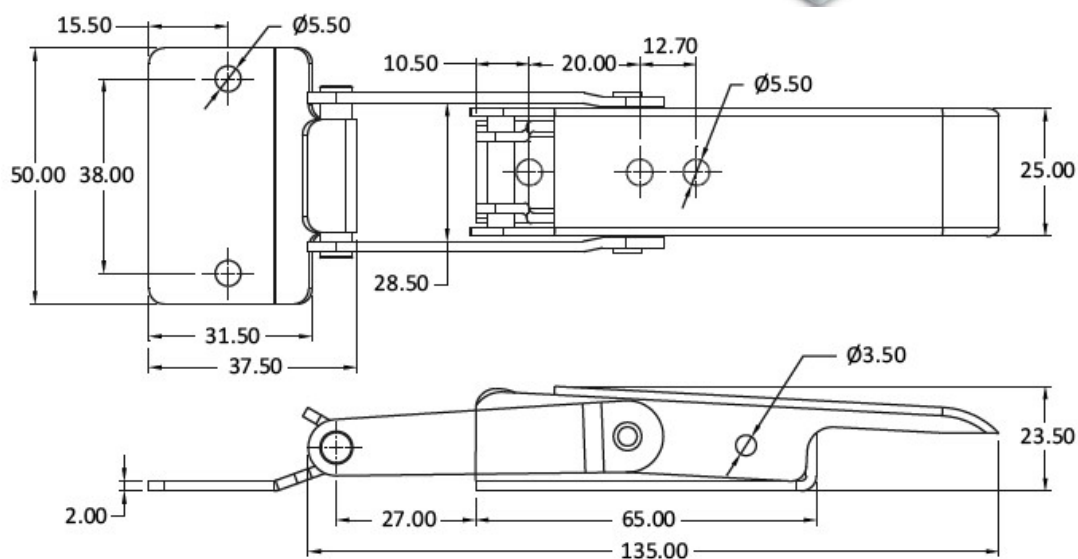
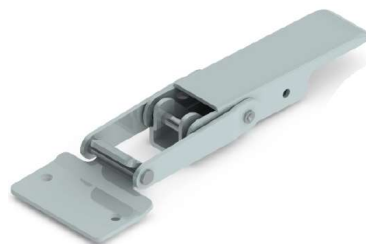

Model No: PAH-70-2600

Holding Capacity: 1.50 kN

Weight: 0.170 kgs

In Stainless Steel: PAH-70-2600-SS

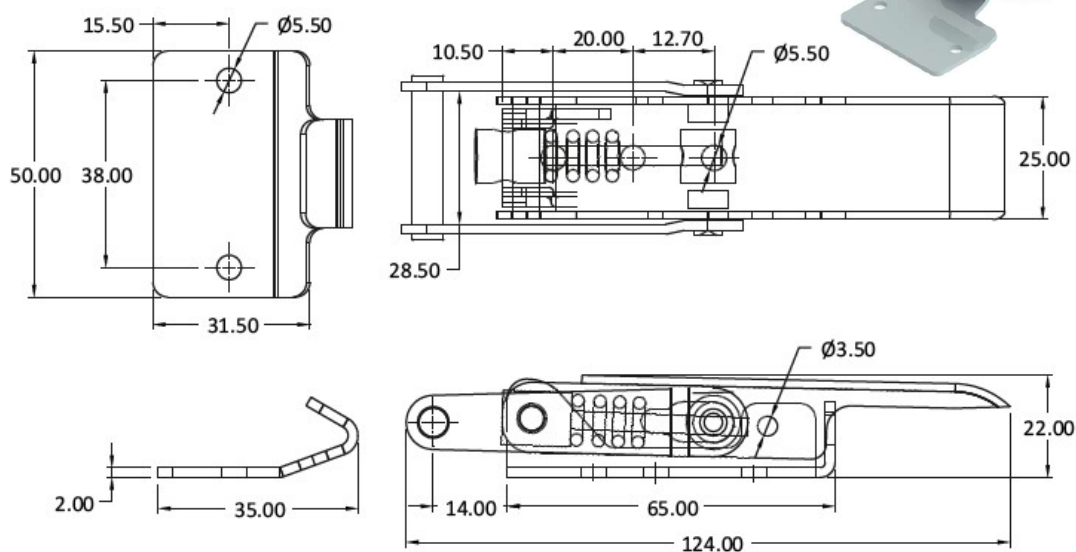

www.conceptlatch.com.au

sales@conceptlatch.com.au

03 9388 2551



Concept Latch Lock & Hinge

Model No: PAH-70-2573

Holding Capacity: 7.40 kN

Weight: 0.150 kgs

In Stainless Steel:

PAH-70-2573-SS

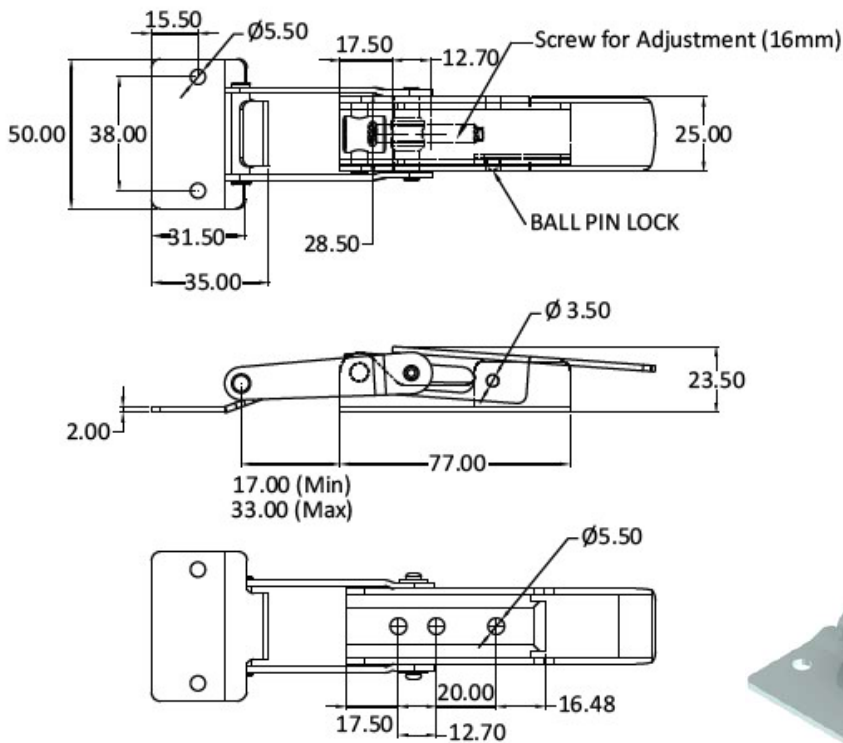
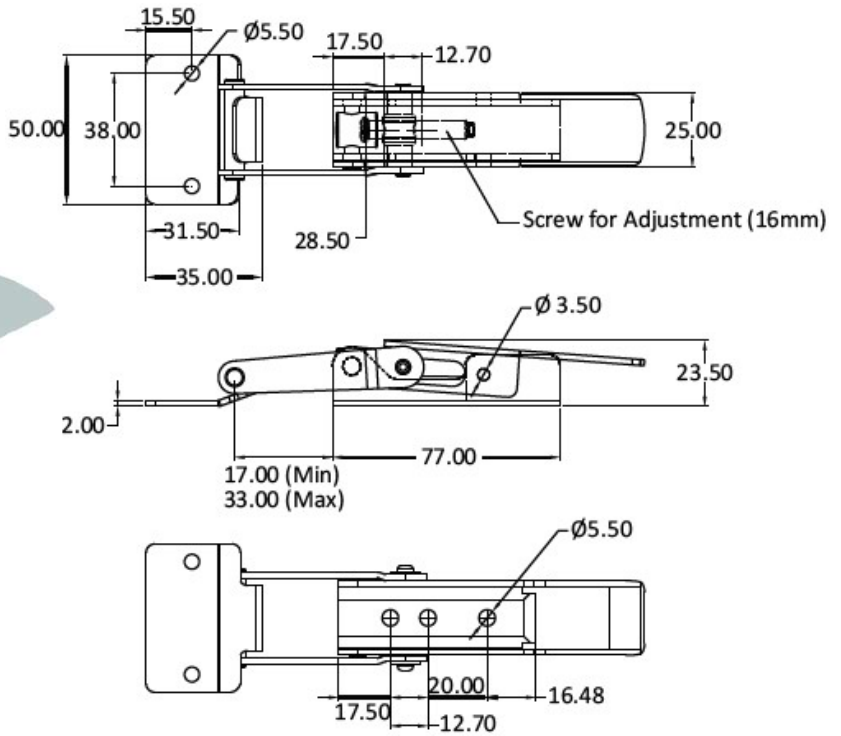

Model No:

PAH-61-200-BATRIG

Holding Capacity: 7.40 kN

Weight: 0.150 kgs

In Stainless Steel:

PAH-61-200-BATRIG-SS



www.conceptlatch.com.au

sales@conceptlatch.com.au

03 9388 2551