

## Steel-Smith Latch Clamps - Small

**Model No: PAH-CT-0313**

Holding Capacity: 0.10 kN

Weight: 0.017 kgs

In Stainless Steel: PAH-CS-0313-SS

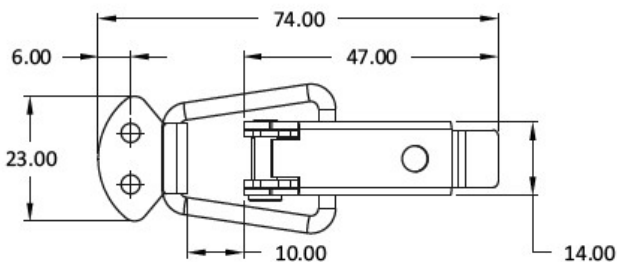
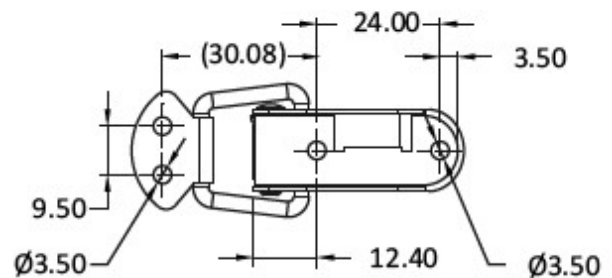
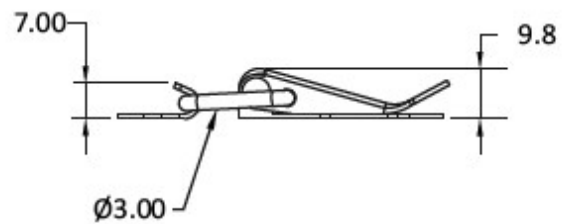
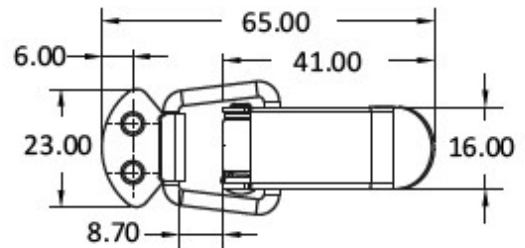

**Model No: PAH - 4813**

Holding Capacity: 0.50 kN

Weight: 0.030 kgs

In Stainless Steel: PAH-4813-SS

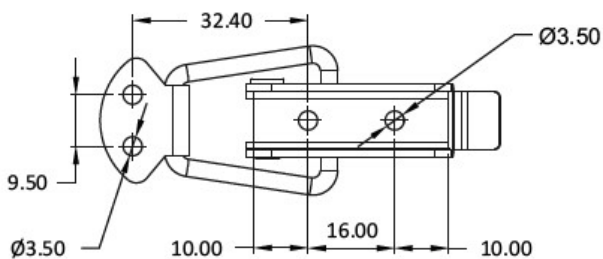
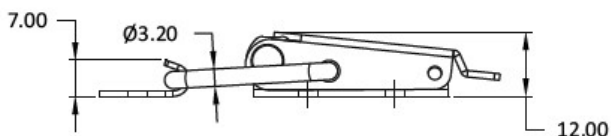

[www.conceptlatch.com.au](http://www.conceptlatch.com.au)

[sales@conceptlatch.com.au](mailto:sales@conceptlatch.com.au)

03 9388 2551

**Keepers Both Suitable for Model Numbers:**

PAH-0313

PAH -4813

PAH - CT-10103

PAH - CT-10104

PAH - CT-10105

**Model No: FH-02-531**

Weight - 0.002 kgs

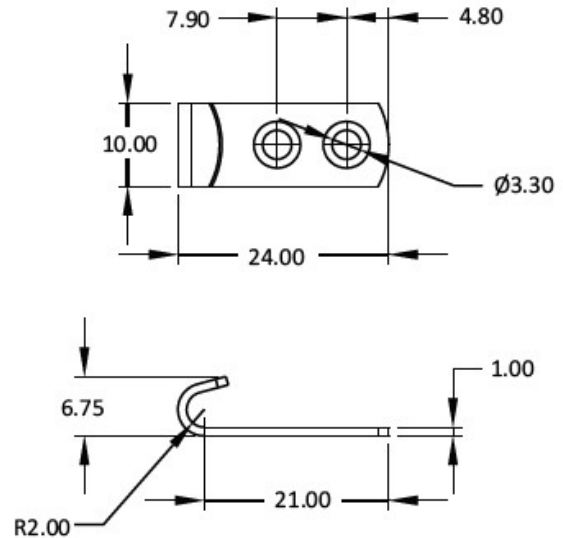

**Model No: FH-03-613**

Weight - 0.030 kgs

