

Red actuators employ a unique spring detent feature. The spring detent holds the intended lazy action latch in its designated position. This feature is the principle used with many P.O.P. Locks products.

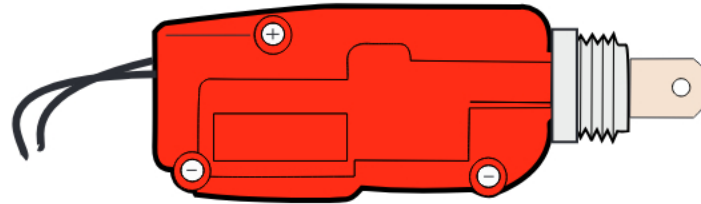

Side View

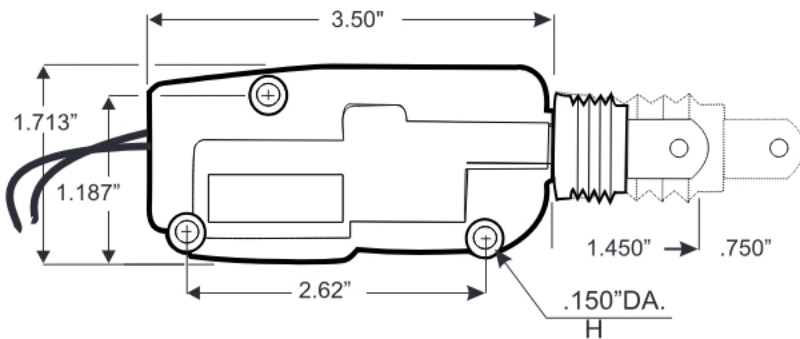

End View

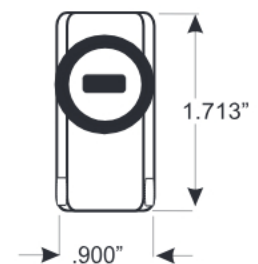

Flat Act™ actuators share critical dimensions allowing crossover components i.e.; bases, covers and connecting linkages to be interchanged.

Nominal Voltage, 12 Volt  
Current with blocked rotor, 3 amp

1) Operational Force

VOLTAGE	TEMPERATURE	FORCE
13v+	20oC	30N
13v+	70oC	25N
13v+	25oC	30N

2) Operational Test Tolerance for test result -10%, +30%

1 Cycle  
Test  
Load = 1 opening and one closing movement  
= 180,000 cycles  
= 20N  
Test cycle power on 0.5 seconds power off 15.0 seconds.

Motor to be cooled by fan at 50 Celsius.

# TECHNICAL SPECIFICATION

## FLAT ACT™ ACTUATORS

### 3) TEMPERATURE AND MOISTURE TEST

1 CYCLE=6 HOURS AT 80oC DRY HEAT

6 HOURS AT 50oC 98% HUMIDITY

6 HOURS AT -25oC

TRANSFER BETWEEN TEMPERATURES WITHIN THREE MINUTES REPEAT FOR 10 CYCLES (TOTAL 180 HOURS)

AT THE END OF THE TEST THERE SHOULD BE NO DEFORMATION OF PARTS OR BREAKAGE.

THE ACTUATOR SHOULD FUNCTION AS STANDARD.

### 4) SALT SPRAY TEST

PLACE DEVICE IN SALT FOR CHAMBER FOR 96 HOURS.

DEVICE SHOULD THEN FUNCTION AS STANDARD.

### 5) PROTECTION AGAINST EXCESSIVE VOLTAGES

THE ACTUATOR MUST WITHSTAND A SPIKE INPUT 24 VOLTS.

### 6) ELECTROMAGNETIC COMPATIBILITY

THE ACTUATOR MUST CONFORM TO THE REQUIREMENTS PRINTED IN GENERAL MOTORS SPECIFICATIONS Qt12 6521

### 7) RADIO INTERFERENCE

THE ACTUATOR MUST NOT AFFECT RADIO RECEPTION OR RADIO TELEPHONE TRANSMISSION. THE REQUIREMENTS ARE PRINTED IN GENERAL MOTORS QT 12 537 DOCUMENT.

# TECHNICAL SPECIFICATION FLAT ACT™ ACTUATORS

- 8) **ELECTRICAL INSULATION**  
THERE SHOULD BE AN INSULATION RESISTANCE HIGHER THAN 10M WITH APPLIED VOLTAGE OF 500V cc BETWEEN ONE TERMINAL AND MASS.
- 9) **IMPERMEABILITY TO WATER**  
THE ACTUATOR MUST BE WATERTIGHT TO THE REQUIREMENTS OF D.I.N. 40 050. THE TEST SHOULD BE CARRIED OUT WITH THE ACTUATOR IN ITS FITTED POSITION.
- 10) **CABLE SECURITY**  
ALL FITTED CABLES SHOULD NOT PULL OUT UNDER A LOAD OF 50N.
- 11) **VIBRATION TEST**  
5-60Hz FOR TWO HOURS AT 23oC  
AMPLITUDE 0.5MM  
CYCLE TIME ONE MINUTE  
VIBRATION DIRECTION VERTICAL TO MOUNTING
- 12) **CASING MATERIAL CHEMICAL RESISTANCE**  
THE TESTS TO BE MADE TO THE MAIN OUTER CASING OF THE ACTUATOR BY THE 'SPOT' METHOD. THE MATERIAL SHALL SHOW NO SIGNS OF DETERIORATION TO:  
PETROLEUM  
GREASE  
HYDRAULIC FLUID