



# E5 Cam Latch

Stainless steel · Tool operated · Fixed grip

- Single hole install
- Latched / unlatched indicator
- EN 45545-3 E60 Compliant

### Material and Finish

Stainless steel, 304 or 316 grade

### Performance Details

Maximum static load:

304 Stainless steel 550 N (124 lbf)

316 Stainless steel 670 N (150 lbf)

### Sealing Notes

NEMA 4 / IP65 achieved using gasket supplied

### Installation Notes

Mounting nut:

Maximum tightening torque:

20 N·m (177 in·lbf)

Screw Maximum tightening torque

10 N·m (90 in·lbf)

### Keys and Accessories

See page 120 and 169-175

### Part Number Selection

See table

Order latch and cam separately

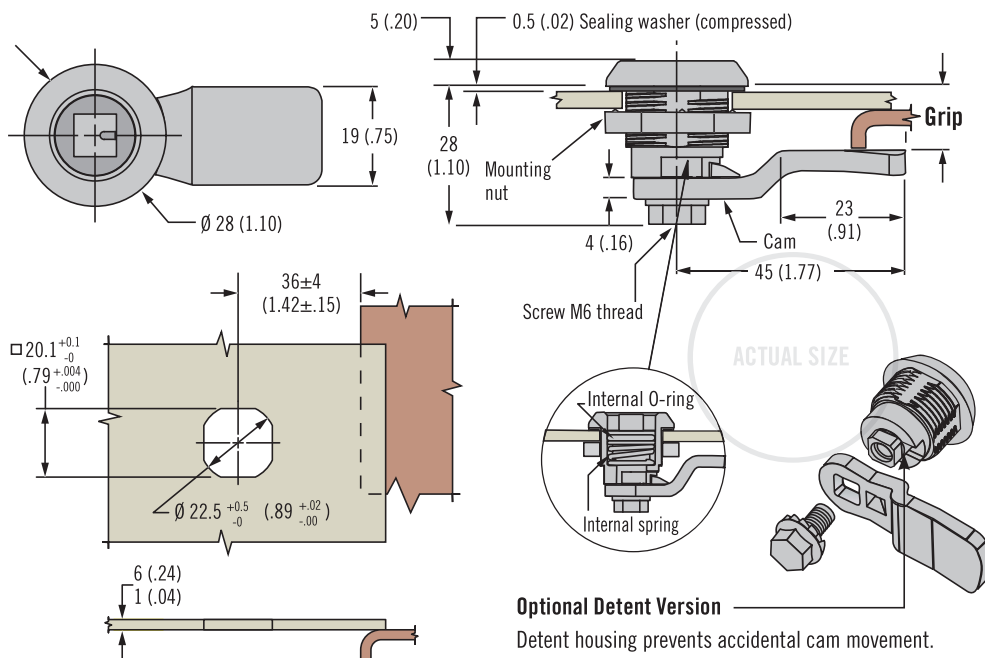

### H Head Styles

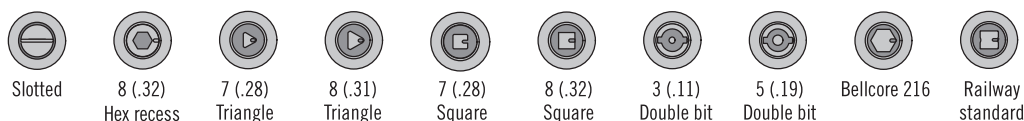

**Latch Part Number (no cam)**

**E5 - B - H M - UU1**

**B Body**

- 6 Normal housing
- 32 Detented housing

**H Head style**

- 00 Slotted
- 01 8 (.32) Hex recess
- 02 7 (.28) Triangle
- 03 8 (.32) Triangle
- 04 7 (.28) Square
- 05 8 (.32) Square
- 06 3 (.11) Double bit
- 07 5 (.19) Double bit
- 13 Bellcore 216
- 22 Railway standard

**M Material**

- 24 304 Stainless steel
- 27 316 Stainless steel

Cam Part Number Table (order separately from latch)

Grip +2(.08) -0(.00)	Part Number		Grip +2(.08) -0(.00)	Part Number		Grip +2(.08) -0(.00)	Part Number		Grip +2(.08) -0(.00)	Part Number	
	304 Stainless steel	316 Stainless steel		304 Stainless steel	316 Stainless steel		304 Stainless steel	316 Stainless steel		304 Stainless steel	316 Stainless steel
4 (.16)	E5-8003	E5-9003	14 (.55)	E5-8008	E5-9008	24 (.94)	E5-8013	E5-9013	34 (1.34)	E5-8018	E5-9018
6 (.24)	E5-8004	E5-9004	16 (.63)	E5-8009	E5-9009	26 (1.02)	E5-8014	E5-9014	36 (1.42)	E5-8019	E5-9019
8 (.31)	E5-8005	E5-9005	18 (.71)	E5-8010	E5-9010	28 (1.10)	E5-8015	E5-9015	38 (1.50)	E5-8020	E5-9020
10 (.39)	E5-8006	E5-9006	20 (.79)	E5-8011	E5-9011	30 (1.18)	E5-8016	E5-9016	40 (1.57)	E5-8021	E5-9021
12 (.47)	E5-8007	E5-9007	22 (.87)	E5-8012	E5-9012	32 (1.25)	E5-8017	E5-9017	42 (1.65)	E5-8022	E5-9022