

# Southco® Quarter-turn Fasteners

## Swell Action Series

- No receptacle required
- Vibration-resistant
- Two sizes, two head styles
- Use in nearly any material and in blind applications



### Material and Finish

WING: 1010 Steel, zinc plate, chromate plus sealer. SLOTTED HEAD STUDS: 1008 Steel, zinc plate, chromate plus sealer. SLEEVE: SBR Rubber. STATIONARY CAM: Acetal, black. MOVING CAM: Die-cast zinc, black organic coating.

Studs are bulk packaged.  
Sleeves and cams are packaged one set per bag.

### Product Strength Guidelines

(To assist in your product selection; samples are available for your evaluation.)

**SERIES 20:** Maximum static load 180 N (40 lbs.)  
Average ultimate load 330 N (75 lbs.)  
**SERIES 50:** Maximum static load 220 N (50 lbs.)  
Average ultimate load 440 N (100 lbs.)

Flammability Rating: UL94-HB  
Operating Temperature Rating: 0°C (30°F) to 65°C (150°F)

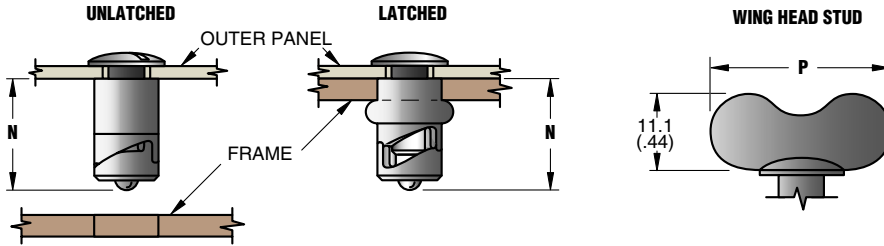

NOTE: Swell latches hold panels snug under short term intermittent loading. Do not apply continuous load.

YOUR OUTER PANEL THICKNESS		F REF.	ASSEMBLY PART NUMBERS		
MIN.	MAX.		L	With Oval Head Stud	With Wing Head Stud

#### SERIES 20

MIN.	MAX.	F REF.	L	With Oval Head Stud	With Wing Head Stud
1.3 (.050)	1.8 (.069)	17.5 (.69)	13.6 (.535)	84-20-060-10 •	84-20-060-20 •
1.8 (.070)	2.3 (.089)	18 (.71)	14.1 (.555)	84-20-080-10 •	84-20-080-20 •
2.3 (.090)	2.8 (.109)	18.5 (.73)	14.6 (.575)	84-20-100-10 •	84-20-100-20 •
2.8 (.110)	3.3 (.129)	19.1 (.75)	15.1 (.595)	84-20-120-10 •	84-20-120-20 •

#### SERIES 50

MIN.	MAX.	F REF.	L	With Oval Head Stud	With Wing Head Stud
1.3 (.050)	1.8 (.069)	21.3 (.84)	16.6 (.654)	84-50-060-10 •	84-50-060-20 •
1.8 (.070)	2.3 (.089)	21.8 (.86)	17.1 (.674)	84-50-080-10 •	84-50-080-20 •

SERIES	DIMENSIONS												
	A	B	C	D	E	G	H	J	K	M	N	O	P
20	9.5 (.38)	2.3 (.09)	6.4 (.25)	11.1 (.44)	12.7 (.50)	11.9 (.47)	17.5 (.69)	152.4 (6.00)	11.1 (.44)	33.3 (1.31)	15.9 (.63)	9.7 (.39)	22.2 (.88)
50	14.3 (.56)	3.0 (.12)	7.9 (.31)	13.5 (.53)	15.9 (.63)	20.6 (.81)	20.6 (.81)	139.7 (5.50)	14.3 (.56)	30.2 (1.19)	19.8 (.78)	14.6 (.58)	28.6 (1.13)

### Assembly

NOTE: On hinged doors, minimum mounting distance from Q hinge to C fastener = 152.4 (6).

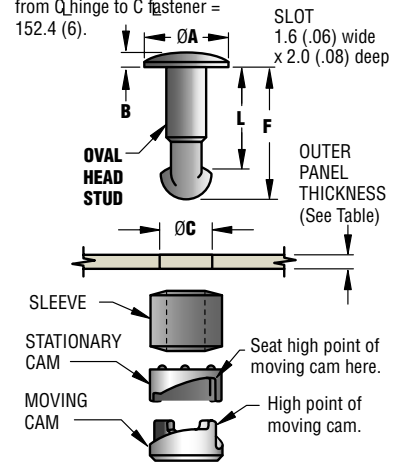

A. When frame thickness is 3.2 (.125) or less:

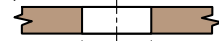

B. When frame thickness is 3.2 (.125) or more:

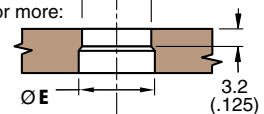

C. For blind hole applications:

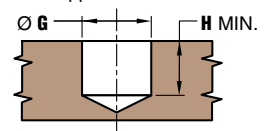

millimeter (inch)  
millimeter (inch)

Dimensions without tolerances are for reference only.

### Side Mount Bracket

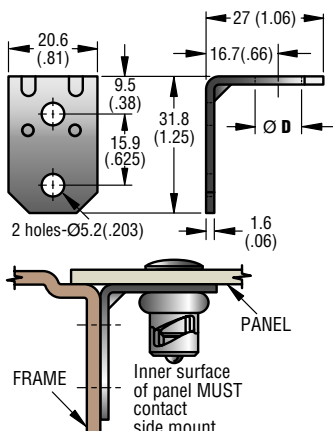

### Bracket Material and Finish

Steel, zinc plated, yellow chromate dip.

### Installation Tool

(Order separately by part number)

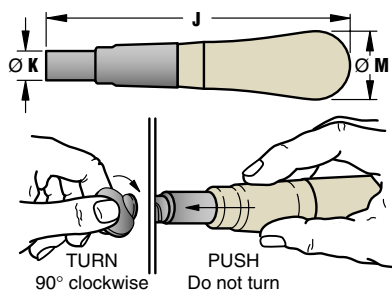

BRACKET PART NUMBERS	
SERIES 20	SERIES 50
84-0-15742-11 •	19-0-15665-11 •

TOOL PART NUMBERS	
SERIES 20	SERIES 50
82-0-14719-11 •	41-0-12125-11 •

Quarter-turn Fasteners Swell Action