

# SPRING HINGE (DOUBLE ACTION) DA



- Opens in both directions inside and outside.
- Spring loaded for self-closing.
- Spring tension adjustable with three steps with a hex key.
- Opening angle is 180°.
- All parts including shaft and spring made of stainless steel (SUS304).
- Anodised type is also available in black, white, gold, bronze colours. (Made to order / MOQ: 2 pcs)

TORQUE HINGES

DAMPER HINGES

LIFT ASSIST HINGES

DETENT HINGES

CONCEALED HINGES

BUTT HINGES

PIANO HINGES

STEP HINGES

LIFT-OFF HINGES

PIVOT HINGES

SPRING HINGES

CLEAN ROOM HINGES

HINGES FOR ALUMINIUM FRAME

DROP HINGES

GLASS DOOR HINGES

SPECIAL HINGES

### [Special Colours (made to order)]

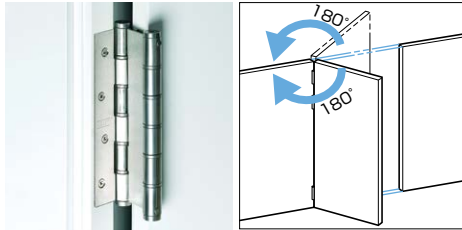

Hinges for double action door.

### [Installation]

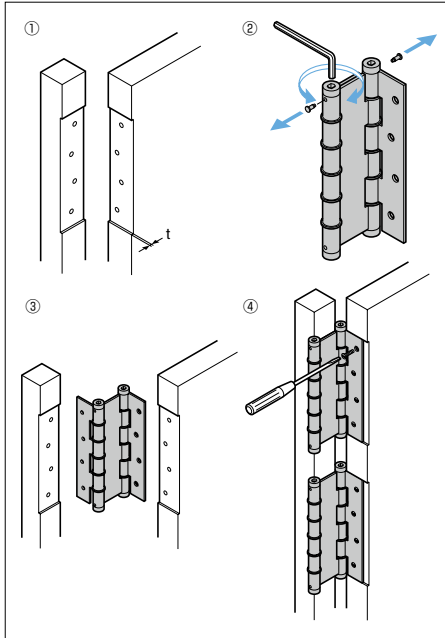

### [Relationship Between Door Height and Door Weight]

	DA120	DA180
Recommended Door Height	1800-2500 mm	
Min. Door Height	500 mm	800 mm
Door Weight	Door Height: Max. 1800mm	
	Reduce by 1.1 kg for lowering 100mm each time.	Reduce by 2.1 kg for lowering 100mm each time.

### [Remarks]

- In case of noise, apply lubricant (grease) to washer and torsion spring.

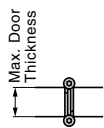
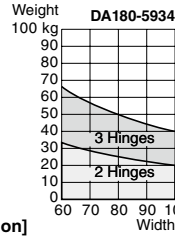
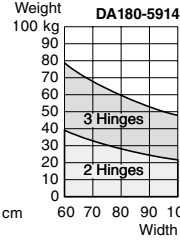
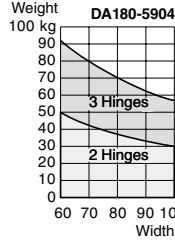
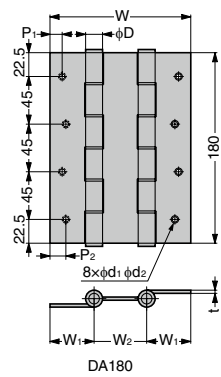
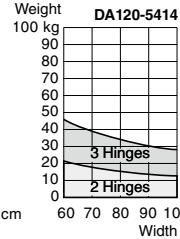
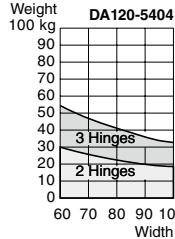
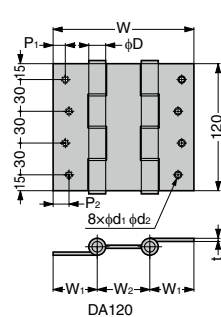

### [How to Adjust Spring Tension]

- Figure below shows the case of left-hanging.

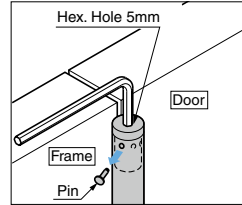

Loosen shaft with a hex key and remove the pin.

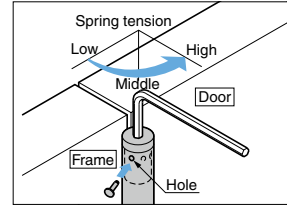

Adjust spring tension with three steps. Put the pin to the hole and fix.

RHS	CAD	Item Code	Item Name	Material	Finish	W	W <sub>1</sub>	W <sub>2</sub>	P <sub>1</sub>	P <sub>2</sub>	D	t	d <sub>1</sub>	d <sub>2</sub>	Max. Door Thickness	Opening Angle	Screw	Weight (g)	Box (pcs)
☑	3D	170-090-803	DA120-5404-01	Aluminium Alloy	Anodised	101	29.5	42	6.5	11.5	16	4	5.3	10	30	180°	-	275	2
☑	3D	170-090-804	DA120-5414-01		Plain	133	40	53	11	16	17	2.5	5.5	9	36			Countersunk Head Tapping Screw	555
☑	3D	170-090-805	DA120-5414-05	Stainless Steel (SUS304)	Plain	101	29.5	42	6.5	11.5	16	4	5.3	10	30		407	2	
☑	3D	170-090-806	DA180-5904-01			Aluminium Alloy	Anodised	101	29.5	42	6.5	11.5	16	4	5.3		10	40	466
☑	3D	170-090-807	DA180-5914-01	Stainless Steel (SUS304)	Plain	133	40	53	11	16	18	3	5.5	9	38	Countersunk Head Tapping Screw	947	2	
☑	3D	170-090-808	DA180-5914-05			Aluminium Alloy	Anodised	157	48.5	60	19.5	24.5	16	4	5.3	10	50	510	2

Please contact your local agent or your nearest Sugatsune subsidiary for detail/availability.