

| REVISIONS | | | | |
|-----------|------|------------------|---------|----------|
| ZONE | REV. | DESCRIPTION | DATE | APPROVED |
| | 01 | DRAWING RELEASED | 4/04/18 | CP |

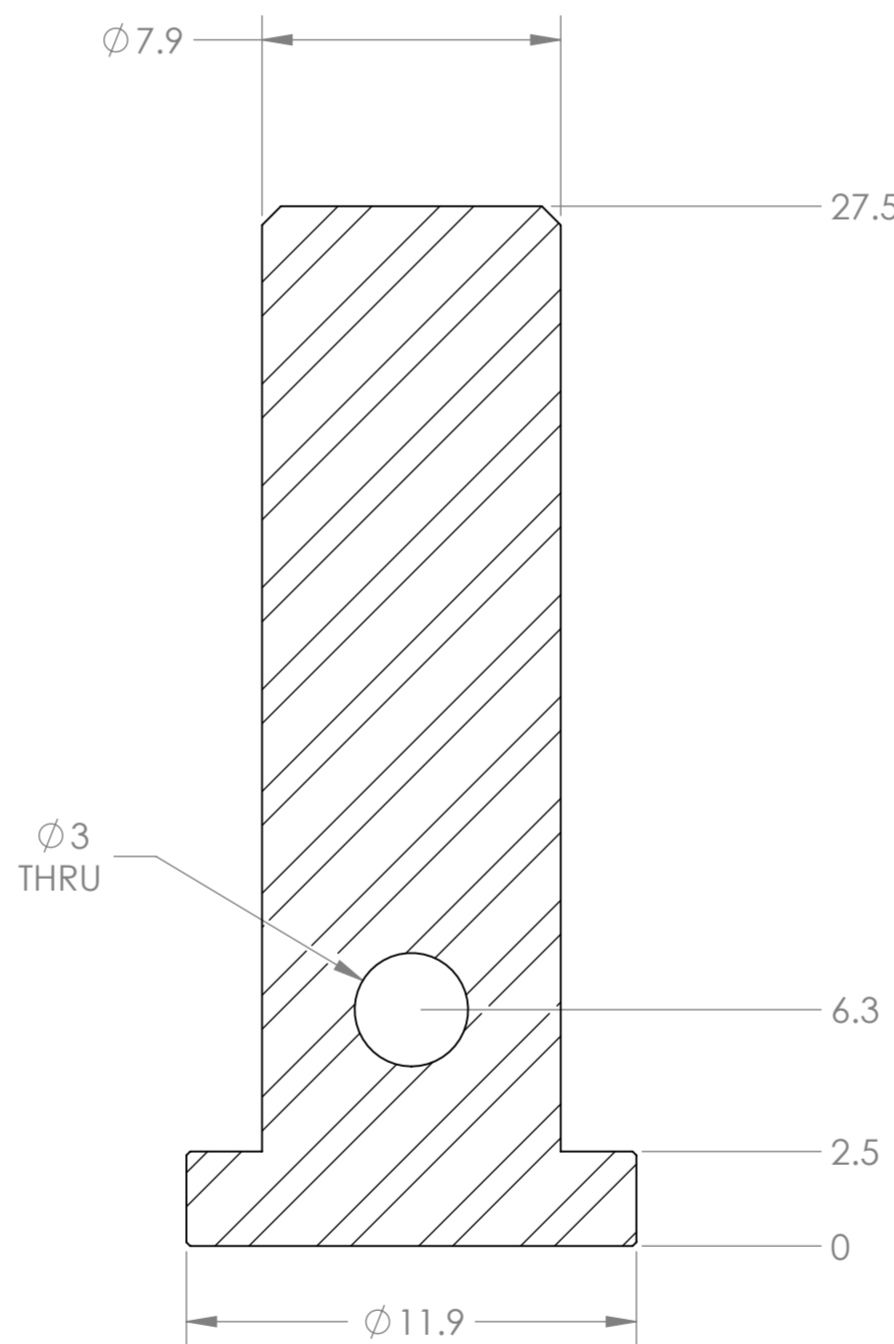

SECTION F-F

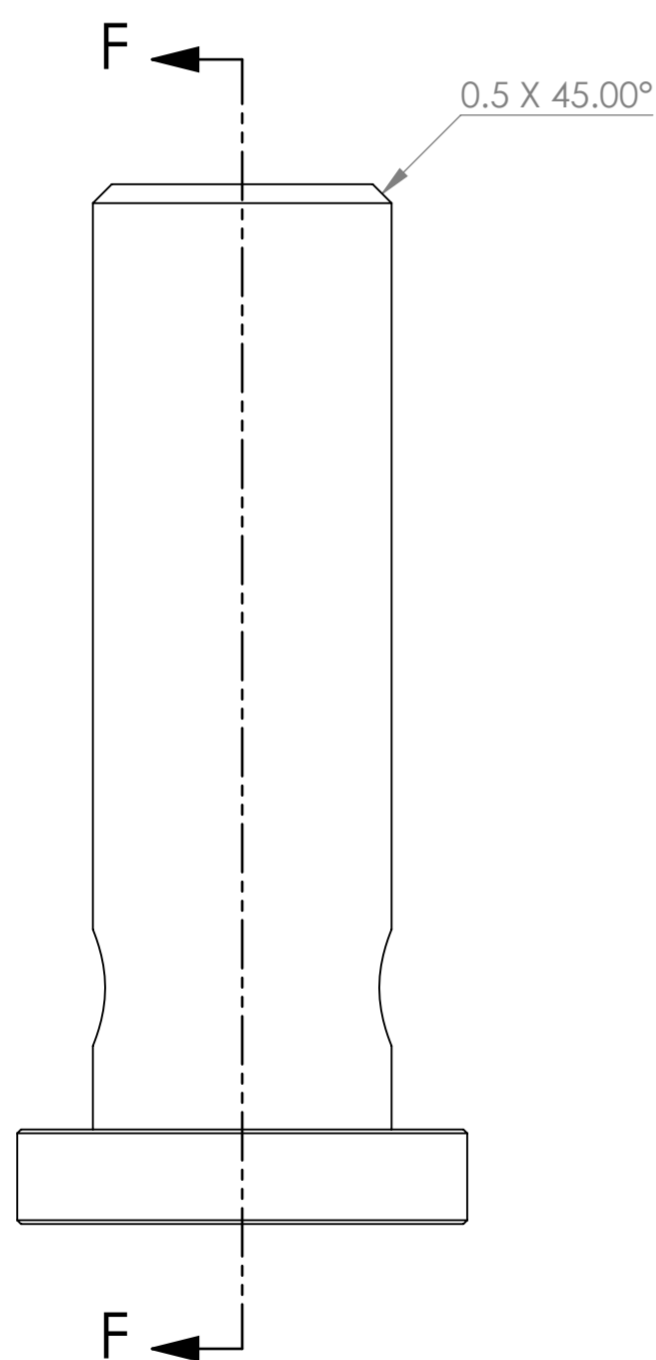
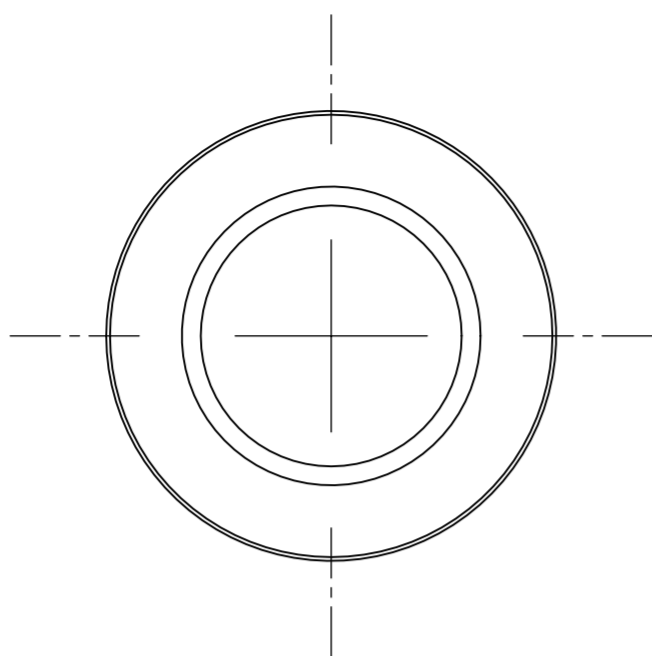
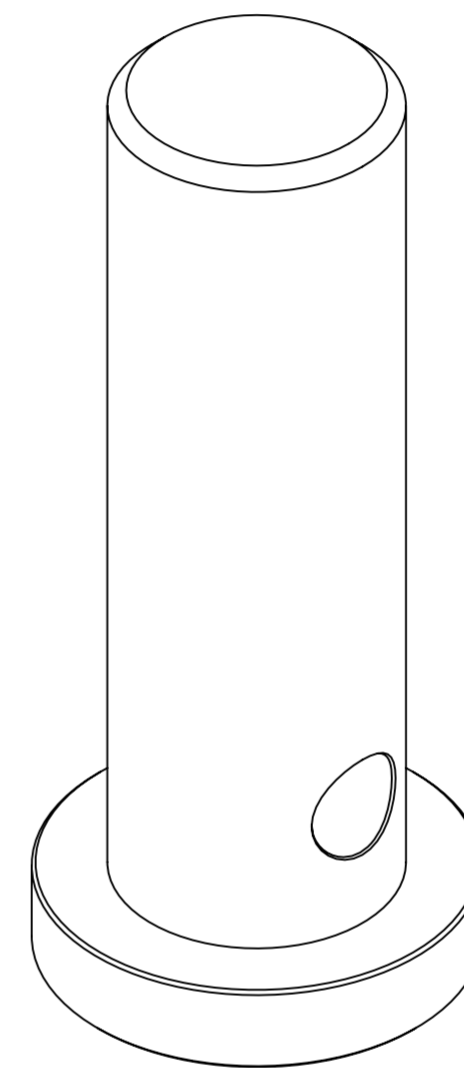

NOTE:

- PART IS SYMMETRICAL ABOUT CL, UNLESS OTHERWISE STATED
- FOLDING AT 90 DEGREE UNLESS OTHERWISE STATED
- REMOVE BURRS AND SHARP EDGES
- SYMBOL FOLDING DIMENSION ARE CRITICAL
- DIMENSIONS START FROM DATUM UNLESS OTHERWISE SPECIFIED



PROPRIETARY AND CONFIDENTIAL
 THE INFORMATION CONTAINED IN THIS DRAWING IS THE SOLE PROPERTY OF APMI PTY LTD.
 ANY REPRODUCTION IN PART OR AS A WHOLE WITHOUT THE WRITTEN PERMISSION OF ACTICO PICKERING METAL IND PTY LTD IS PROHIBITED.

| | | | | | | | | | |
|---|-----------|------------------------|--|-----------------------------|--|----------------------|--|---------------------------------------|--|
| UNLESS OTHERWISE SPECIFIED: DIMENSIONS ARE IN MILLIMETERS GENERAL TOLERANCES APPLY: | | FINISH: ZINC PASSIVATE | | DEBUR AND BREAK SHARP EDGES | | DO NOT SCALE DRAWING | | REVISION 01 | |
| APMI-SOP-004 | | | | | | APMI Pty Ltd | | 28 Quality Drive, Dandenong, VIC 3175 | |
| NAME | SIGNATURE | DATE | | | | TITLE: CONCEPT PIN | | | |
| DRAWN: CB | | 4/04/2018 | | | | | | | |
| CHK'D: CP | | 4/04/2018 | | | | | | | |
| APPV'D | | | | | | | | | |
| MFG | | | | | | | | | |
| Q.A | | | | | | MATERIAL: MS | | DWG NO. CONCEPT PIN A2 | |
| | | | | | | WEIGHT: | | SCALE: 5:1 SHEET 1 OF 2 | |