

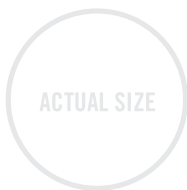

61 Cam Latch

Universal cabinet series · Adjustable grip

Knob Style

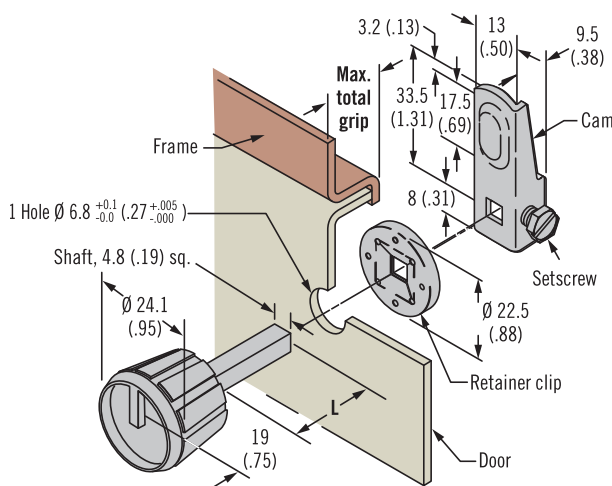

- Single hole installation
- Accommodates wide grip ranges

Material and Finish

Nylon and steel, zinc plated

Performance Details

Maximum static load: 110 N (25 lbf)

Notes

Knob style shown. Additional L-handle and flush slotted styles available

Other options available. For complete details on variety, part numbers, installation and specification, go to

Maximum Total Grip	Shaft Length L	Assembly Part number
12.5 (.50)	25.5 (1.00)	61-10-102-11
25 (1.00)	38 (1.50)	61-10-104-11
44.5 (1.75)	57 (2.25)	61-10-107-11

92 Cam Latch

T, Compact-T and L-handle · Adjustable grip



Compact T-handle

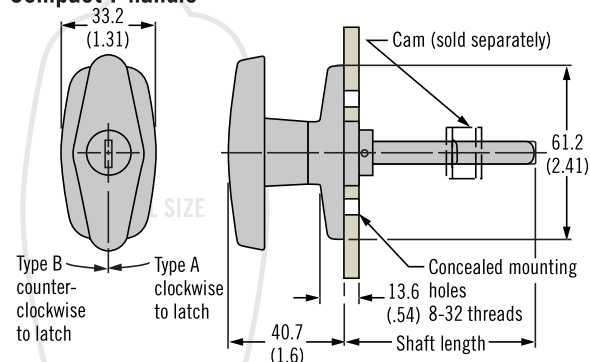

Cam

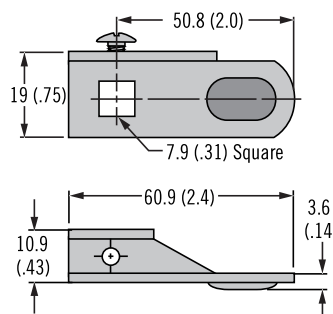

- Easy cam adjustments

Material and Finish

Zinc alloy, powder coated or chrome plated and steel, zinc plated

Performance Details

Maximum static load: 150 N (34 lbf)

Notes

Black and chrome finish available
 For versions with threaded shaft see page 208.
 For fixed grip versions see page 162.
 Gasket Part Number: 92-70-G (sold separately)

Finish	Shaft Length	Locking Compact-T Part Number	
		Type A	Type B
Black	38.1 (1.5)	92-61-113-50	92-61-213-50
	50.8 (2.0)	92-61-114-50	92-61-214-50
	63.5 (2.5)	92-61-115-50	92-61-215-50

Cam Part Number
92-24-203-12

Compact T-handle style shown. T and L-handle style available. Locking and non-locking.

Dimensions in millimeters (inch) unless otherwise stated



Other options available. For complete details on variety, part numbers, installation and specification, go to

www.southco.com/92