

E5 Cam Latch

Zinc · Shutter · Tool operated · Fixed grip

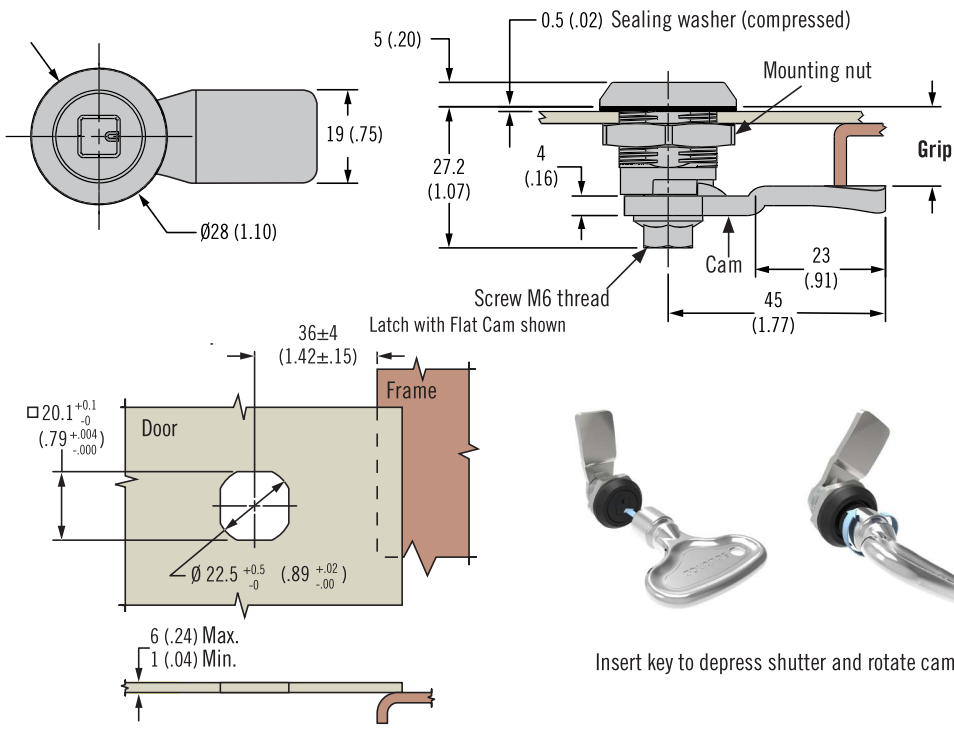

- Single hole install
- Latched / unlatched detent
- Vibration resistant
- EN 61373 Compliant

Material and Finish

Zinc alloy, powder coated or chrome plated and steel, zinc plated

Performance Details

Maximum static load: 330 N (74 lbf)

Installation Notes

Mounting nut maximum tightening torque: 10 N·m (88 in·lbf)

Screw Maximum tightening torque: 5 N·m (45 in·lbf)

Sealing Notes

NEMA 4 / IP65 achieved using gasket supplied

Keys and Accessories

See page 120 and 169-175

H Head Styles

- 7 (.28)
 Triangle
- 8 (.32)
 Triangle
- 7 (.28)
 Square
- 8 (.32)
 Square
- Bellcore
 216

Insert key to depress shutter and rotate cam

Latch Part Number (no cam)

E5 - 8 - H F - UU1

- H** Head style
- 02** 7 (.28) Triangle
 - 03** 8 (.32) Triangle
 - 04** 7 (.28) Square
 - 05** 8 (.32) Square
 - 13** Bellcore 216

- F** Finish
- 2** Bright chrome
 - 5** Black powder coated

Part Number Selection

See table
Order latch and cam separately

Cam Part Number Table (order separately from latch)							
Grip	Part Number	Grip	Part Number	Grip	Part Number	Grip	Part Number
4 (.16)	E5-6003	14 (.55)	E5-6008	24 (.94)	E5-6013	34 (1.34)	E5-6018
6 (.24)	E5-6004	16 (.63)	E5-6009	26 (1.02)	E5-6014	36 (1.42)	E5-6019
8 (.31)	E5-6005	18 (.71)	E5-6010	28 (1.10)	E5-6015	38 (1.50)	E5-6020
10 (.39)	E5-6006	20 (.79)	E5-6011	30 (1.18)	E5-6016	40 (1.57)	E5-6021
12 (.47)	E5-6007	22 (.87)	E5-6012	32 (1.25)	E5-6017	42 (1.65)	E5-6022



Dimensions in millimeters (inch) unless otherwise stated

www.southco.com/E5