

APPLICATIONS: Full extension and a disconnect method for light duty applications in metal furniture or carts.

Full Extension Box Drawer Slide
Pocket and Bayonet Mount
Up to 100 lb. [45 kg.] Capacity*

Inches
[mm]

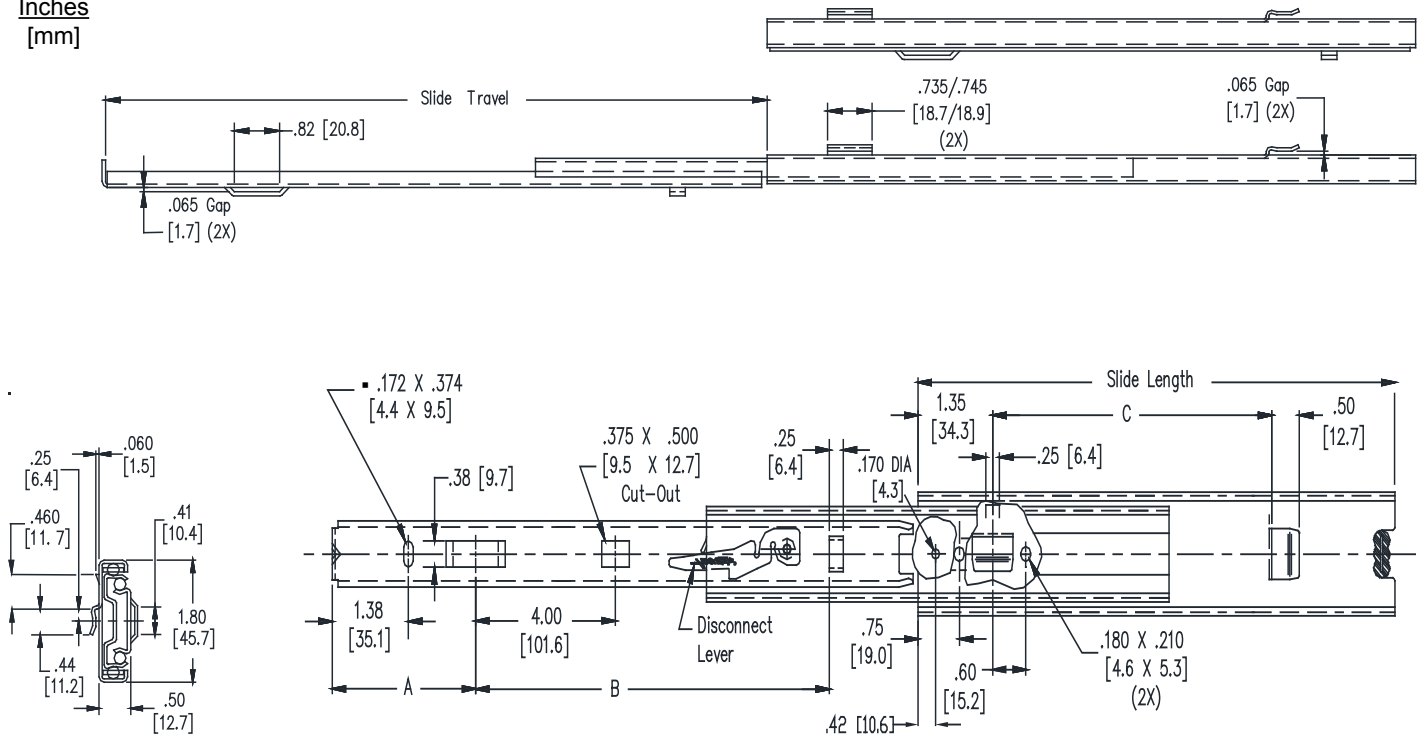

• Not available in
12" [305] Length

- Finish** Bright electro-zinc (C) plating•
- Length** Even lengths 12"–28" [305 mm–700 mm]
- Travel** Full extension
- Height** 1.80" [45.7 mm]
- Load** 100 lbs. [45 kg.]
- Side Space** .50" [12.7 mm]
- Drawer Width** Maximum 16" wide
- Mounting** Lever disconnect
- Disconnect** Pocket and bayonet
- Hardware** Not included. Recommended:
Drawer: #8 pan head self-tapping screw
Cabinet: #10 pan head self-tapping screw
- Features** Hold-in detent

Part Number	Slide Length	Slide Travel	A	B	C
3820E-12	12.00 [305]	12.00 [305]	1.30 [33.0]	9.50 [241.3]	9.50 [241.3]
3820E-14	13.78 [350]	14.00 [356]	2.30 [58.4]	9.50 [241.3]	9.50 [241.3]
3820E-16	15.75 [400]	16.00 [406]	2.30 [58.4]	9.50 [241.3]	12.50 [317.5]
3820E-18	17.72 [450]	18.00 [457]	2.80 [71.1]	12.50 [317.5]	12.50 [317.5]
3820E-20	19.69 [500]	20.00 [508]	2.30 [58.4]	15.50 [393.7]	15.50 [393.7]
3820E-22	21.65 [550]	22.00 [559]	3.30 [83.8]	15.50 [393.7]	15.50 [393.7]
3820E-24	23.62 [600]	24.00 [610]	4.30 [109.2]	15.50 [393.7]	15.50 [393.7]
3820E-26	25.59 [650]	26.00 [660]	5.30 [134.6]	15.50 [393.7]	15.50 [393.7]
3820E-28	27.56 [700]	28.00 [711]	6.30 [160.0]	15.50 [393.7]	15.50 [393.7]

* Provide + .030/- .000 [+ .76 mm/.00 mm] tolerance in cabinet design

- Load rating based on an 18" slide on a 16" wide drawer cycled 50,000 times.
- RoHS Compliant

Cabinet Cut-Out Recommendation

See figure 1 for hat section cut-out details.

Front and rear hat sections are identical.

Attach the hat sections to the cabinet sidewall using the pitch pattern recommended in figure 2.

For A dimensions, see table on front page.

NOTE: Minimum recommended material thickness for hat section is .060" [1.52 mm] or 16 gauge.

Set back=thickness of inset drawer front where applicable + .12" [3.1 mm] clearance.

Mounting Slide to Cabinet

1. Insert the cabinet member rear bayonet tab into the rear hat section cut-out (see figure 3).
2. Lower the slide until the front bayonet tab engages the front cut-out.
3. Insert the front tab into the trapezoidal cut-out. Push firmly downward until the tab snaps into place and the retention lug is engaged (see figure 3).
4. The retention lug prevents the cabinet member from lifting and disengaging from the cabinet.
5. Repeat procedure on opposite side of cabinet for the companion slide.

Drawer Cut-Out Recommendations

See figure 4 for drawer cut-out details.

For B dimension (figure 5) see table on front page. For optimum slide performance, it is recommended that the slide centerline be located at the centerline of the drawer side or slightly toward the plane of the drawer pull.

Cut-out recommendation is based on 16-gauge material.

If a thinner material is used, adjustment to the cut-outs must be made to ensure a proper fit. Refer to the table below for the recommended modifications.

Gauge	Material Thickness	Dimension D	Dimension E
16	.060 [1.52]	.855 [21.7]	.395 [10.0]
18	.048 [1.22]	.865 [22.0]	.405 [10.3]
20	.036 [.91]	.885 [22.5]	.425 [10.8]
22	.030 [.76]	.905 [23.0]	.435 [11.1]

* For dimension B, see tabulated table on page one.

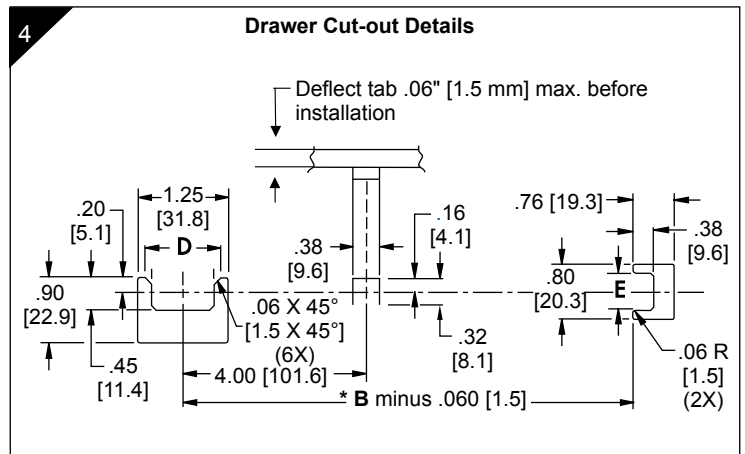
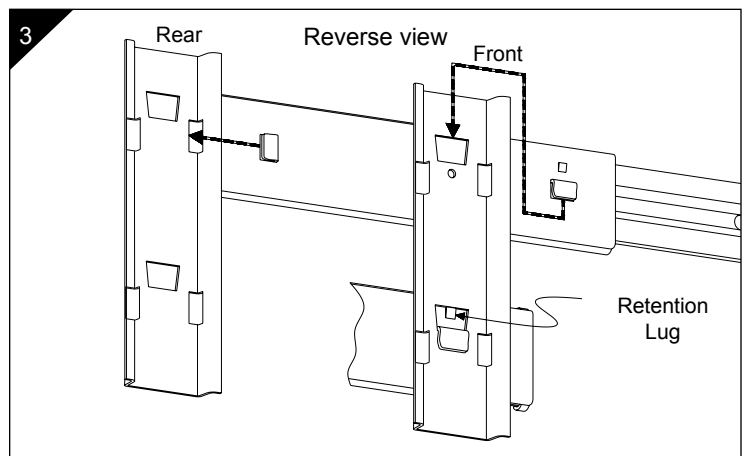
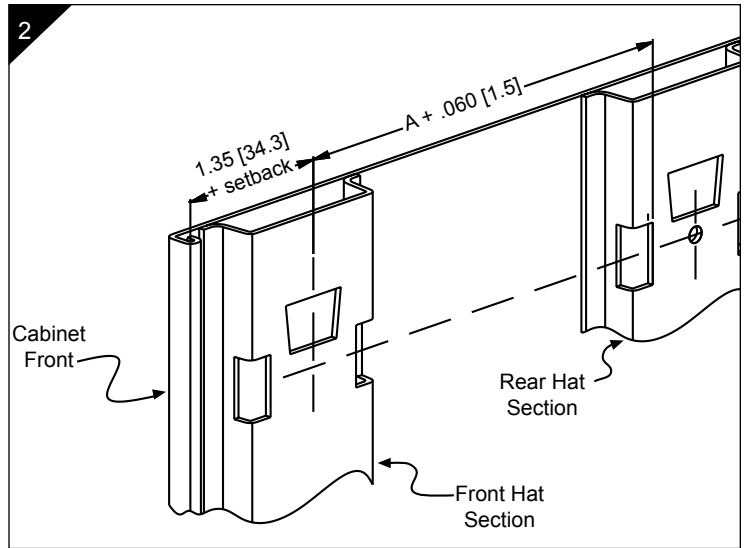
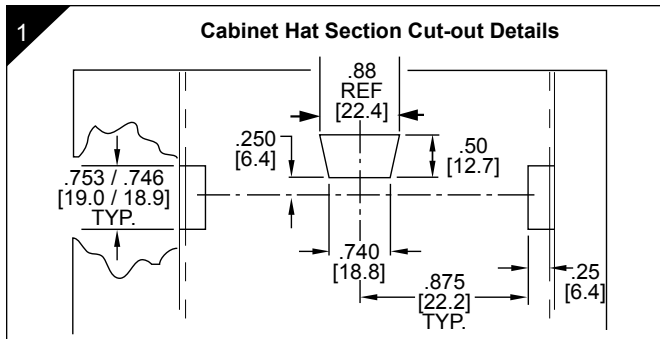

Mounting Slide to Drawer

1. Using recommended placement of drawer bayonets (figure 5), extend both right and left hand drawer members.
2. Insert rear drawer tabs into rear slide pockets. Guide front tabs into front pockets and push firmly into place making sure the retention lug snaps into the cut-out on drawer member.
3. The drawer retention lug will adequately protect the drawer from lifting and disengaging from the slide.

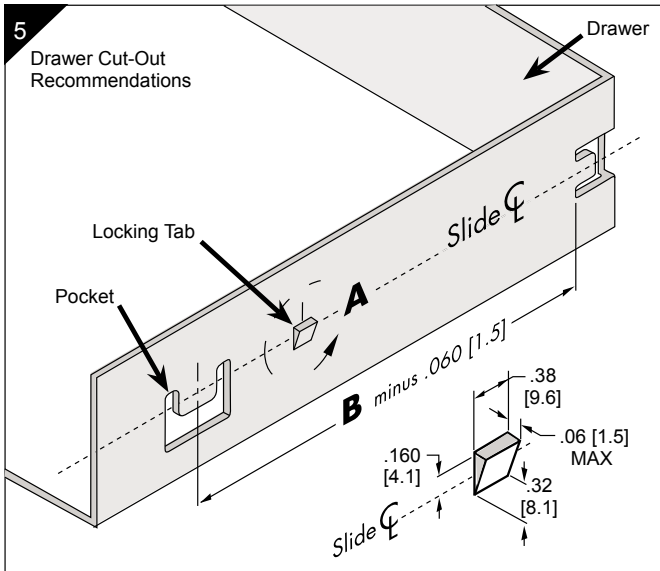

Slide Ordering Instructions

Complete your slide order by specifying the following:

Model 3820E Slide

	100 Each	C	3820E	-16
Total Required Slides				
Slide Finish				
Model Number				
Slide Length				

Packaging

Bulk packaging only. D-pack not available.
 Slides packaged in boxes (no polybags).
 Left and right hand slides are boxed separately in bulk;
 20 ea. per box.

Specifications

Slide members: Cold-rolled steel
 Ball bearings: Carburized steel
 RoHS compliant
 Note: Specifications, materials, prices, terms, and delivery are subject to change without notice.



ACCURIDE INTERNATIONAL INC.

12311 Shoemaker Avenue
 Santa Fe Springs, CA 90670
 TEL (562) 903-0200
 FAX (562) 903-0208
 www accuride.com

Manufacturing, Engineering, and Sales
 United States • Germany • Japan • Mexico • United Kingdom • China

Copyright © 2017 Accuride International Inc. 3700-9526(1214)-MK132-R2-0817