

**ROLLON**<sup>®</sup>  
BY TIMKEN

*Eco System*



**ECO series****> ECO series description**

Fig. 1

The ECO SYSTEM units are linear actuators made of a self-supporting extruded aluminum frame and are driven by a polyurethane belt with AT metric profile steel inserts.

- Three different sizes available: 60mm, 80mm, 100mm
- Version available with recirculating ball bearing or roller rails
- Reduced weight ensured by the light frame and the aluminum sliders
- High sliding speed

The ECO SYSTEM series actuators are offered with two motion systems:

**ECO SYSTEM – SP**

Featuring a maintenance free recirculating linear guide rail fitted inside the profile.

**ECO SYSTEM – CI**

Featuring four rollers with a Gothic arch outer profile sliding on hardened steel bars placed inside the profile.

## > The components

### Extruded bodies

The anodized aluminum extrusion used for the profile of the Rollon ECO series linear units was designed and manufactured by industry experts to optimise weight while maintaining mechanical strength. The anodized aluminum alloy 6060 used (see physical-chemical characteristics below) was extruded with dimensional tolerances compliant with EN 755-9 standards.

### Driving belt

The Rollon ECO series linear units use steel reinforced polyurethane drive belts with AT pitch. This belt is ideal due to its high load transmission characteristics, compact size and low noise. Used in conjunction with a backlash-free pulley, smooth alternating motion can be achieved.

Optimisation of the maximum belt width/body dimension ratio enables the following performance characteristics to be achieved:

- **High speed**
- **Low noise**
- **Low wear**

The driving belt is guided by specific slots in the aluminum extruded body thus covering the inside components.

### Carriage

The carriage of the Rollon ECO series linear units is made of anodized aluminum. Two different length carriages are available for each type of linear unit.

### General data about aluminum used: AL 6060

Chemical composition [%]

Al	Mg	Si	Fe	Mn	Zn	Cu	Impurities
Remaining	0.35-0.60	0.30-0.60	0.30	0.10	0.10	0.10	0.05-0.15

Tab. 1

Physical characteristics

Density	Coeff. of elasticity	Coeff. of thermal expansion (20°-100°C)	Thermal conductivity (20°C)	Specific heat (0°-100°C)	Resistivity	Melting point
$\frac{\text{kg}}{\text{dm}^3}$	$\frac{\text{kN}}{\text{mm}^2}$	$\frac{10^{-6}}{\text{K}}$	$\frac{\text{W}}{\text{m} \cdot \text{K}}$	$\frac{\text{J}}{\text{kg} \cdot \text{K}}$	$\Omega \cdot \text{m} \cdot 10^{-9}$	°C
2.70	69	23	200	880-900	33	600-655

Tab. 2

Mechanical characteristics

Rm	Rp (02)	A	HB
$\frac{\text{N}}{\text{mm}^2}$	$\frac{\text{N}}{\text{mm}^2}$	%	—
205	165	10	60-80

Tab. 3

## > The linear motion system

The linear motion system has been designed to meet the load capacity, speed, and maximum acceleration conditions of a wide variety of applications. Two linear motion systems are offered:

### ECO...SP with ball bearing guides

- A ball bearing guide with high load capacity is mounted in a dedicated seat on the inside of the aluminum body.
- The carriage is assembled on two pre-loaded ball bearing blocks.
- The two ball bearing blocks enable the carriage to withstand loading in the four main directions.
- The two blocks have seals on both sides and, if necessary, an additional scraper can be fitted for very dusty conditions.
- The ball bearing carriages of the SP versions are also fitted with a retention cage that eliminates "steel-steel" contact between adjacent revolving parts and prevents misalignment.
- Lubrication reservoirs (pockets) installed on the front of the ball bearing blocks supply the appropriate amount of grease, thus promoting a long maintenance interval.

#### The linear motion system described above offers:

- High speed and acceleration
- High load capacity
- High permissible bending moments
- Low friction
- Long life
- Maintenance Free (dependent on application)
- Low noise
- Suitable for long stroke

### ECO...CI with gothic arch bearing guides inside the body

- Two hardened steel rods (58/60 HRC tolerance h6) are securely inserted inside the aluminum body.
- The carriage is fitted with six bearing assemblies each having a gothic arch groove machined into its outer race to run on the steel rods.
- The six bearings are mounted on steel pins, two of which are eccentric, to allow setting of running clearance and pre-load.
- To keep the running tracks clean and lubricated, four grease impregnated felt seals, complete with grease reservoirs, are fitted on the ends of the carriage.
- The driving belt is supported by the entire length of the profile in order to avoid deflection as well as to protect the linear guide.

#### The linear motion system described above offers:

- Good positioning accuracy
- Low noise
- Maintenance Free (dependent on application)

ECO SP

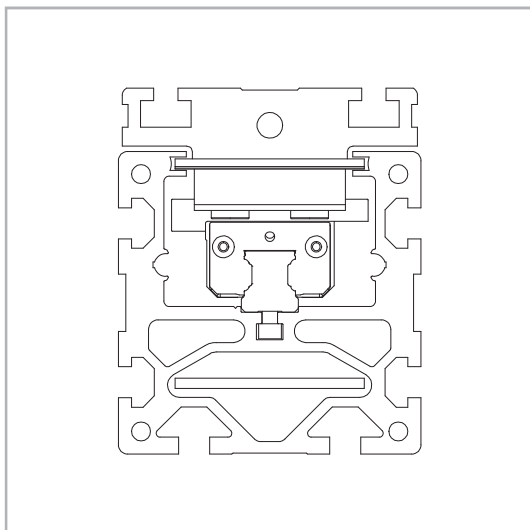

Fig. 2

ECO CI

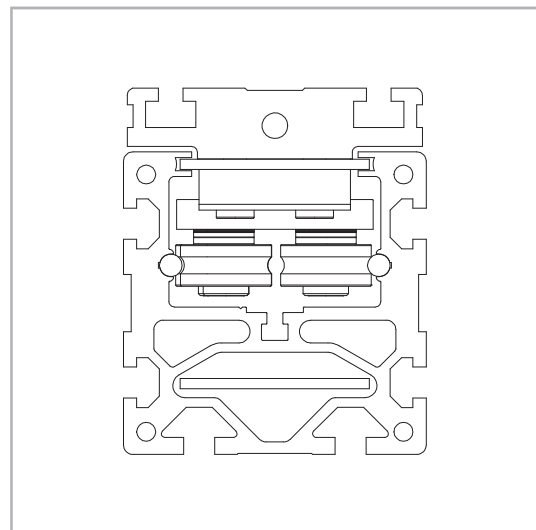
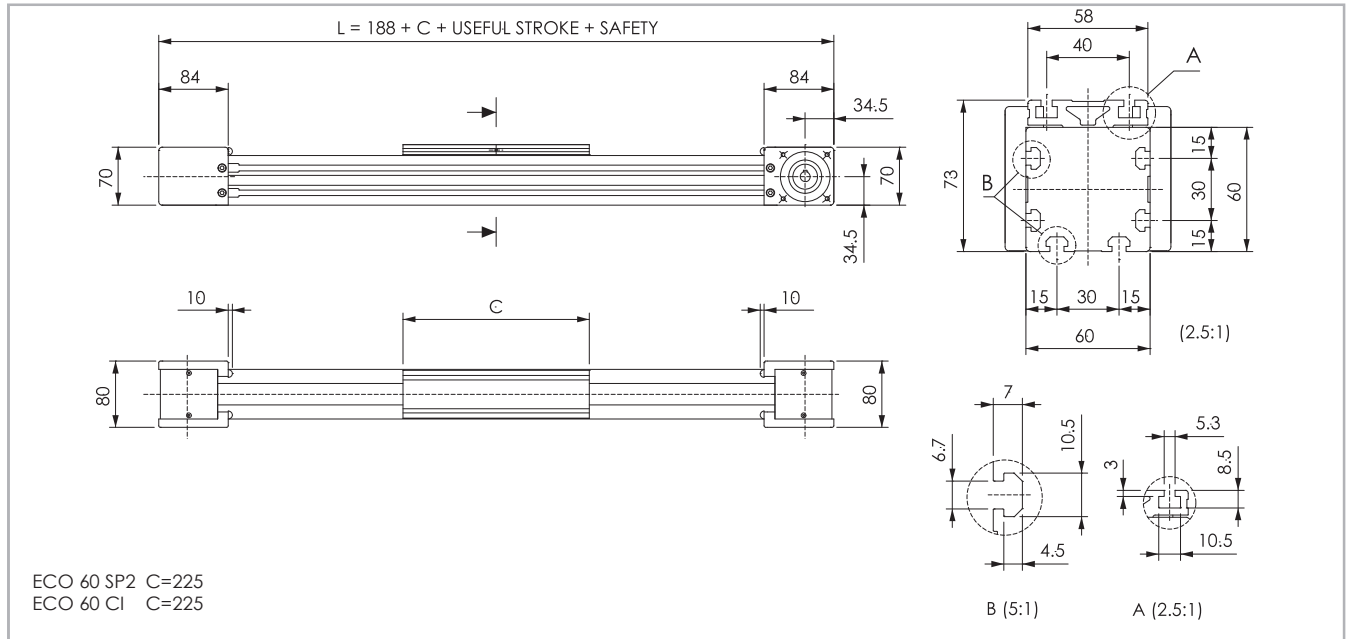

Fig. 3

> ECO 60 SP2 - ECO 60 CI

ECO 60 SP2 - ECO 60 CI Dimensions



The length of the safety stroke is provided on request according to the customer's specific requirements.

Fig. 4

Technical data

	Type	
	ECO 60 SP2	ECO 60 CI
Max. useful stroke length [mm]	6025	5725
Max. positioning repeatability [mm]*1	± 0.05	± 0.05
Max. speed [m/s]	4.0	1.5
Max. acceleration [m/s <sup>2</sup> ]	50	1.5
Type of belt	32 AT 5	32 AT 5
Type of pulley	Z 28	Z 28
Pulley pitch diameter [mm]	44.56	44.56
Carriage displacement per pulley turn [mm]	140	140
Carriage weight [kg]	0.51	0.80
Zero travel weight [kg]	3.5	3.2
Weight for 100 mm useful stroke [kg]	0.45	0.68
Starting torque [Nm]	0.24	0.32
Moment of inertia of pulleys [g mm <sup>2</sup> ]	163000	163000
Rail size [mm]	12 mini	Ø6

\*1) Positioning repeatability is dependant on the type of transmission used

Tab. 4

Moments of inertia of the aluminum body

Type	$I_x$ [10 <sup>7</sup> mm <sup>4</sup> ]	$I_y$ [10 <sup>7</sup> mm <sup>4</sup> ]	$I_p$ [10 <sup>7</sup> mm <sup>4</sup> ]
ECO 60	0.037	0.054	0.093

Tab. 5

Driving belt

The driving belt is manufactured with friction resistant polyurethane, with steel cord reinforcement for high tensile stress resistance.

Type	Type of belt	Belt width [mm]	Weight [kg/m]
ECO 60	32 AT 5	32	0.105

Tab. 6

Belt length (mm) SP2/CI = 2 x L - 166

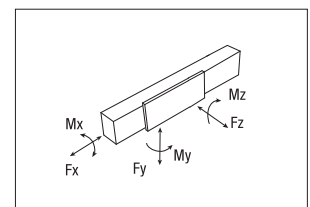

Load capacity

Type	$F_x$ [N]		$F_y$ [N]		$F_z$ [N]	$M_x$ [Nm]		$M_y$ [Nm]		$M_z$ [Nm]	
	Stat.	Dyn.	Stat.	Dyn.	Stat.	Stat.	Stat.	Stat.	Stat.	Stat.	
ECO 60 SP2	1344	922	7060	6350	7060	46.2	325	325	325	325	
ECO 60 CI	1344	922	1648	3072	1110	24.4	33	33	33	76.2	

See verification under static load and Lifetime on page SL-2 and SL-3

Tab. 7

> ECO 80 SP2 - ECO 80 SP1 - ECO 80 CI

ECO 80 SP2 - ECO 80 SP1 - ECO 80 CI Dimensions

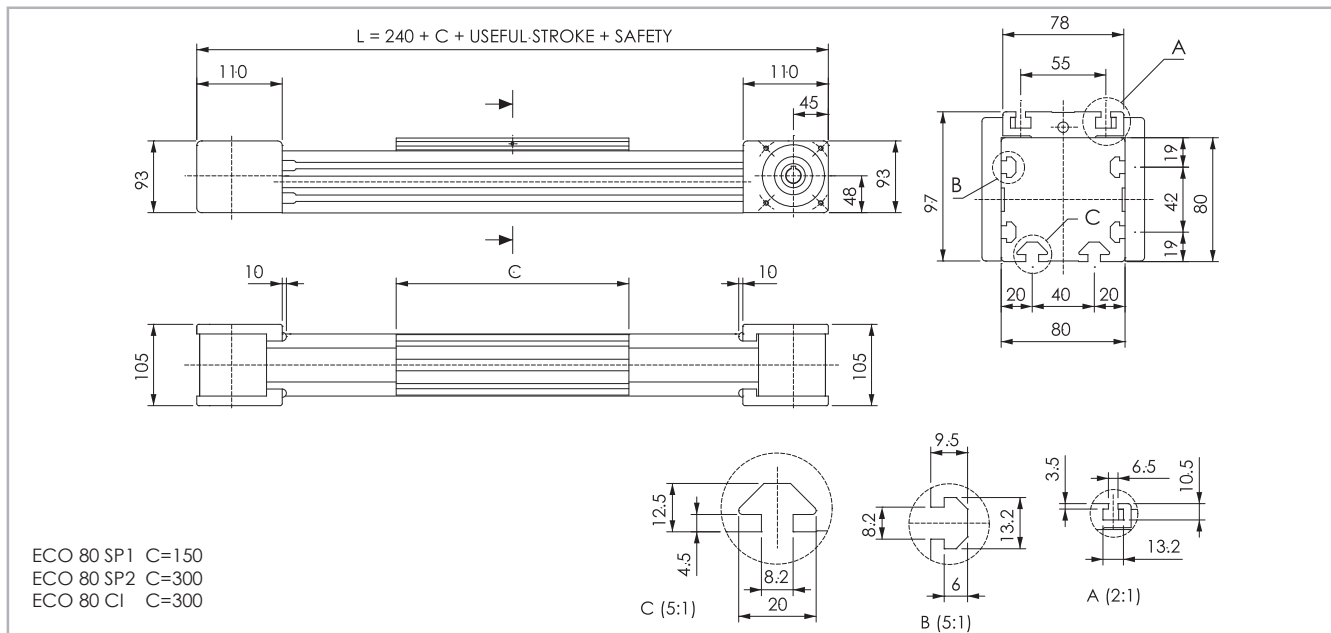

The length of the safety stroke is provided on request according to the customer's specific requirements.

Fig. 5

Technical data

	Type		
	ECO 80 SP2	ECO 80 SP1	ECO 80 CI
Max. useful stroke length [mm]	5940	6090	5640
Max. positioning repeatability [mm]*1	± 0.05	± 0.05	± 0.05
Max. speed [m/s]	5.0	5.0	1.5
Max. acceleration [m/s <sup>2</sup> ]	50	50	1.5
Type of belt	50 AT 5	50 AT 5	50 AT 5
Type of pulley	Z 37	Z 37	Z 37
Pulley pitch diameter [mm]	58.89	58.89	58.89
Carriage displacement per pulley turn [mm]	185	185	185
Carriage weight [kg]	1.6	0.9	2.1
Zero travel weight [kg]	7.7	5.9	8.2
Weight for 100 mm useful stroke [kg]	0.8	0.8	0.65
Starting torque [Nm]	0.75	0.75	0.75
Moment of inertia of pulleys [g mm <sup>2</sup> ]	706000	706000	706000
Rail size [mm]	15	15	Ø6

\*1) Positioning repeatability is dependant on the type of transmission used

Tab. 8

Load capacity

Type	F <sub>x</sub> [N]		F <sub>y</sub> [N]		F <sub>z</sub> [N]	M <sub>x</sub> [Nm]	M <sub>y</sub> [Nm]	M <sub>z</sub> [Nm]
	Stat.	Dyn.	Stat.	Dyn.	Stat.	Stat.	Stat.	Stat.
ECO 80 SP2	2100	1440	25400	19720	25400	240	1791	1791
ECO 80 SP1	2100	1440	12700	9860	12700	120	87	87
ECO 80 CI	2100	1770	4229	8731	2849	83	129	297

See verification under static load and lifetime on page SL-2 and SL-3

Tab. 11

Moments of inertia of the aluminum body

Type	I <sub>x</sub> [10 <sup>7</sup> mm <sup>4</sup> ]	I <sub>y</sub> [10 <sup>7</sup> mm <sup>4</sup> ]	I <sub>p</sub> [10 <sup>7</sup> mm <sup>4</sup> ]
ECO 80	0.117	0.173	0.280

Tab. 9

Driving belt

The driving belt is manufactured with friction resistant polyurethane, with steel cord reinforcement for high tensile stress resistance.

Type	Type of belt	Belt width [mm]	Weight [kg/m]
ECO 80	50 AT 5	50	0.164

Tab. 10

Belt length (mm) SP2/CI = 2 x L - 240

SP1 = 2 x L - 90

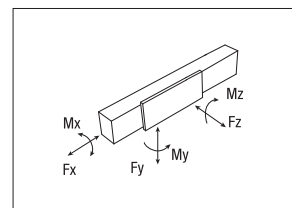

> ECO 100 SP2 - ECO 100 SP1 - ECO 100 CI

ECO 100 SP2 - ECO 100 SP1 - ECO 100 CI Dimensions

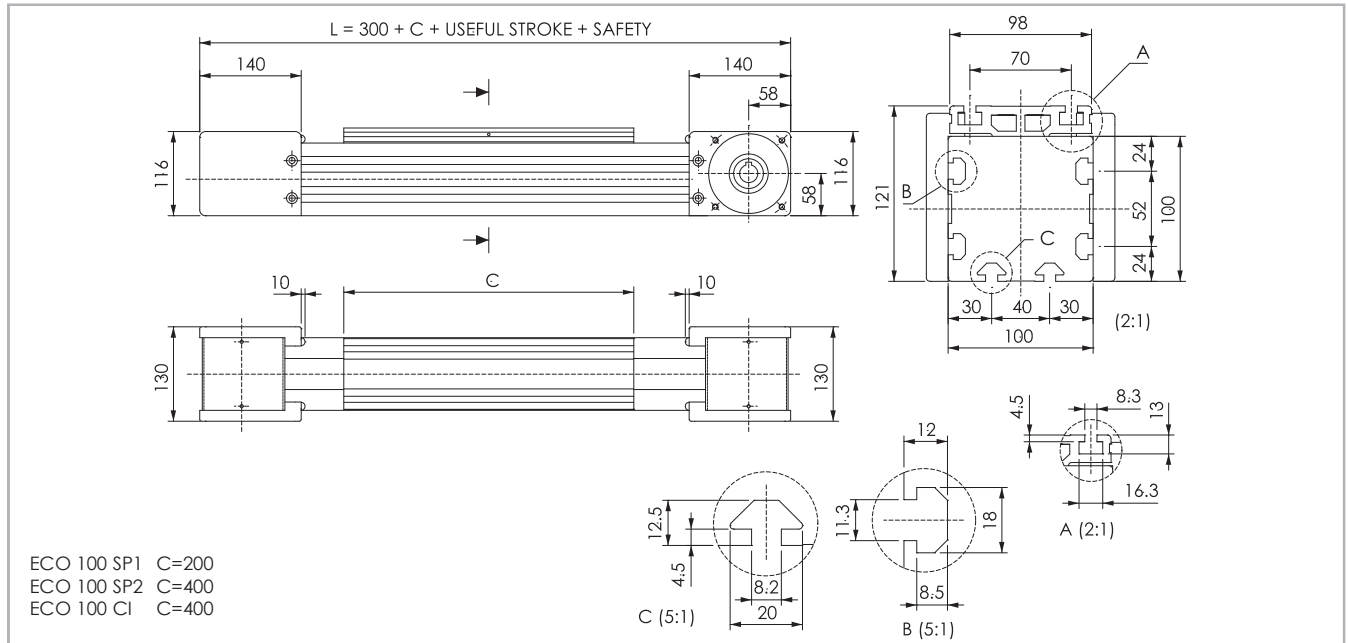

The length of the safety stroke is provided on request according to the customer's specific requirements.

Fig. 6

Technical data

	Type		
	ECO 100 SP2	ECO 100 SP1	ECO100 CI
Max. useful stroke length [mm]	6630	6830	5530
Max. positioning repeatability [mm]*1	± 0.05	± 0.05	± 0.05
Max. speed [m/s]	5.0	5.0	1.5
Max. acceleration [m/s <sup>2</sup> ]	50	50	1.5
Type of belt	50 AT 10	50 AT 10	50 AT 10
Type of pulley	Z 24	Z 24	Z 24
Pulley pitch diameter [mm]	76.39	76.39	76.39
Carriage displacement per pulley turn [mm]	240	240	240
Carriage weight [kg]	2.9	1.5	3.3
Zero travel weight [kg]	16.7	12.5	17.1
Weight for 100 mm useful stroke [kg]	1.3	1.3	1.1
Starting torque [Nm]	1.90	1.35	1.35
Moment of inertia of pulleys [g mm <sup>2</sup> ]	2070000	2070000	2070000
Rail size [mm]	20	20	Ø10

\*1) Positioning repeatability is dependant on the type of transmission used

Tab. 12

Load capacity

Type	F <sub>x</sub> [N]		F <sub>y</sub> [N]		F <sub>z</sub> [N]	M <sub>x</sub> [Nm]		M <sub>y</sub> [Nm]	M <sub>z</sub> [Nm]
	Stat.	Dyn.	Stat.	Dyn.	Stat.	Stat.	Stat.	Stat.	
ECO 100 SP2	4565	2832	55400	44400	55400	700	5485	5485	
ECO 100 SP1	4565	2832	27700	22200	27700	350	240	240	
ECO 100 CI	4565	3740	9154	20079	6167	214	310	962	

See verification under static load and Lifetime on page SL-2 and SL-3

Tab. 15

Moments of inertia of the aluminum body

Type	I <sub>x</sub> [10 <sup>7</sup> mm <sup>4</sup> ]	I <sub>y</sub> [10 <sup>7</sup> mm <sup>4</sup> ]	I <sub>b</sub> [10 <sup>7</sup> mm <sup>4</sup> ]
ECO 100	0.342	0.439	0.781

Tab. 13

Driving belt

The driving belt is manufactured with friction resistant polyurethane, with steel cord reinforcement for high tensile stress resistance.

Type	Type of belt	Belt width [mm]	Weight [kg/m]
ECO 100	50 AT 10	50	0.290

Tab. 14

Belt length (mm) SP1 = 2 x L - 112

SP2/CI = 2 x L - 312

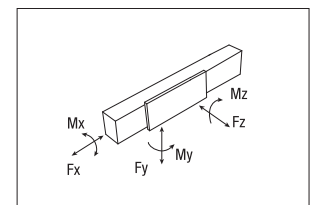

## > Lubrication

### ECO linear units with ball bearing guides

ECO linear are equipped with self lubricating linear ball guides.

The ball bearing carriages of the ECO series are also fitted with a retention cage that eliminates "steel-steel" contact between adjacent revolving parts and prevents misalignment of these in the circuits.

Special lubrication reservoirs are mounted on the front plates of the linear blocks which continuously provide the necessary amount of grease to the ball raceways under load. These lubrication reservoirs also considerably reduce the frequency of lubrication of the module. This system guarantees

a long interval between maintenances: every 5000 km or 1 year of use, based on the value reached first. If a longer service life is required or in case of high dynamic or high loaded applications please contact our offices for further verification.

### ECO

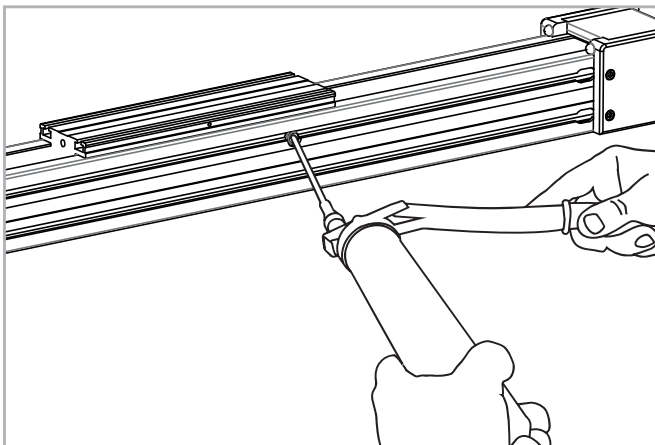

Fig. 7

- Insert the tip of the grease gun in the specific grease blocks.
- For lubrication of linear units use lithium soap grease NLGI 2.
- For specially stressed applications or difficult environmental conditions, lubrication should be carried out more frequently. Refer to Rollon for further advice.

Quantity of lubricant necessary for re-lubrication of each block:

Type	Unit: [cm <sup>3</sup> ]
ECO 60	0.5
ECO 80	0.7
ECO 100	1.4

Tab. 16

## > Simple shafts

### AS type simple shafts

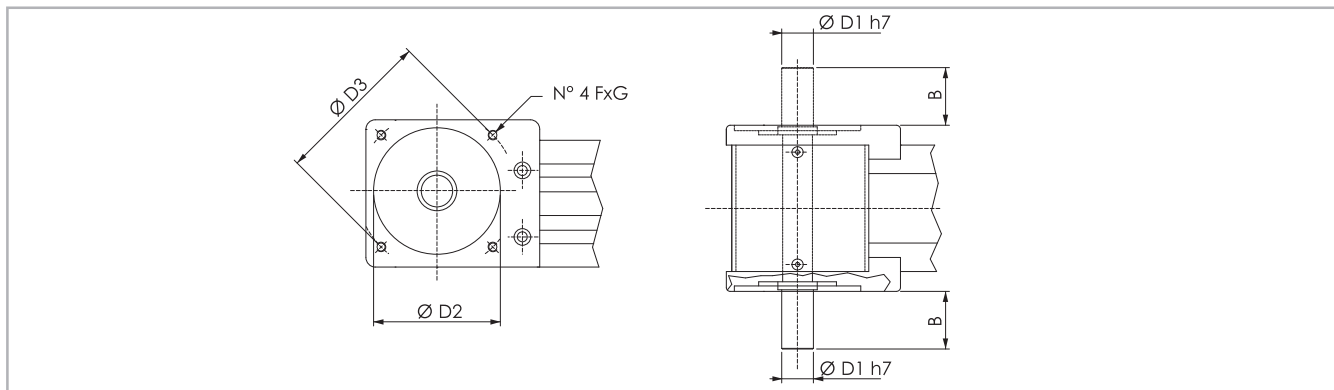

Position of the simple shaft can be to the left or right of the drive head.

Fig. 8

### Dimensions (mm)

Applicable to unit	Shaft type	D1	D2	D3	B	F	G	Head code AS left	Head code AS right
ECO 60	AS 12	12	60	75	25	M5	12	2G	2I
ECO 80	AS 20	20	80	100	36.5	M6	16	2G	2I
ECO 100	AS 25	25	110	130	50	M8	20	2G	2I

Tab. 17

## > Hollow shafts

### Transmission of torque to the drive pulley

Torque is transmitted to the drive pulley from a hollow shaft and keyway.

This system may create backlash in the case of alternating loads and high level acceleration. For further information, contact our offices.

### Hollow shaft

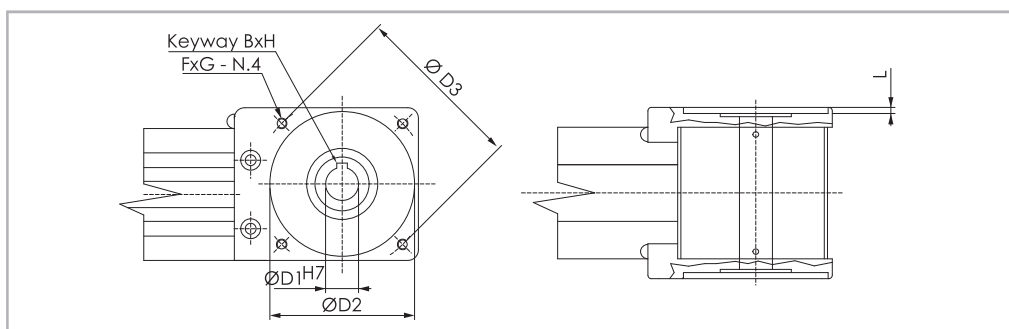

Fig. 9

An (optional) connection flange is required to fit the standard reduction units selected by Rollon.

For further information, contact our offices

Unit	Shaft type	D1	D2	D3	L	Key way BxH	F	G	Drive head code
ECO 60	AC 12	12H7	60	75	3.5	4 x 4	M5	12	2A
ECO 80	AC 19	19H7	80	100	3.5	6 x 6	M6	16	2A
ECO 100	AC 25	25H7	110	130	4.5	8 x 7	M8	20	2A

Tab. 18

## > Linear units in parallel

### Synchronisation kit for use of ECO linear units in parallel

When movement consisting of two linear units in parallel is essential, a synchronisation kit must be used. The kit contains original Rollon blade type precision joints complete with tapered splines and hollow aluminum drive shafts.

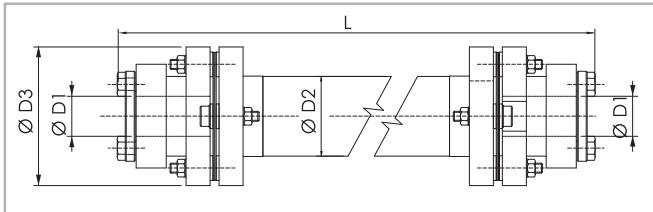

Fig. 10

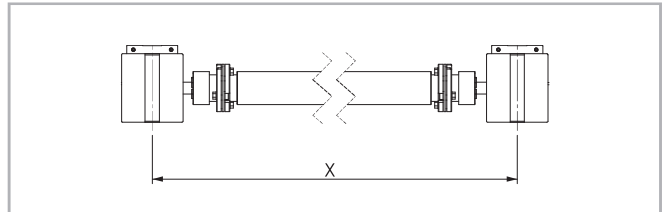

Fig. 11

Unit	Shaft type	D1	D2	D3	Code	Formula for length calculation
ECO 60	AP 12	12	25	45	GK12P...1A	$L = X - 88$ [mm]
ECO 80	AP 20	20	40	69.5	GK20P...1A	$L = X - 116$ [mm]
ECO 100	AP 25	25	70	99	GK25P...1A	$L = X - 165$ [mm]

Tab. 19

## > Accessories

### Fixing by brackets

The linear motion systems used for the Rollon ECO series linear units enables them to support loads in any direction. They can therefore be installed in any position.

To install the units, we recommend use of the dedicated T-slots in the aluminum extruded bodies as shown below.

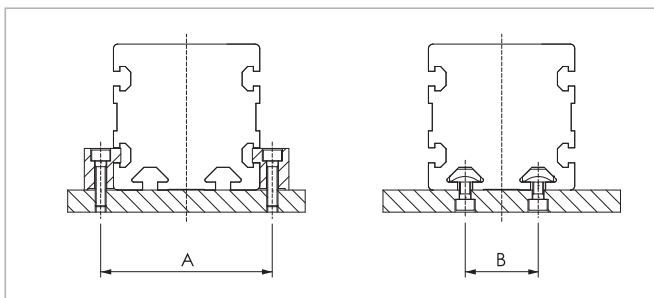

Fig. 12

### Moment of inertia [g mm<sup>2</sup>] C1 + C2 · (X-Y)

	C1	C2	Y	Weight [ Kg ] C1+C2 · (X-Y)	
	[g mm <sup>2</sup> ]	[g mm <sup>2</sup> ]	[mm]	C1 [Kg]	C2 [Kg mm]
GK12P	61.456	69	166	0.308	0.00056
GK20P	1.014.968	464	250	2.48	0.00148
GK25P	5.525.250	4.708	356	6.24	0.0051

Tab. 20

Unit	A (mm)	B (mm)
ECO 60	72	30
ECO 80	94	40
ECO 100	120	40

Tab. 21

Fixing brackets

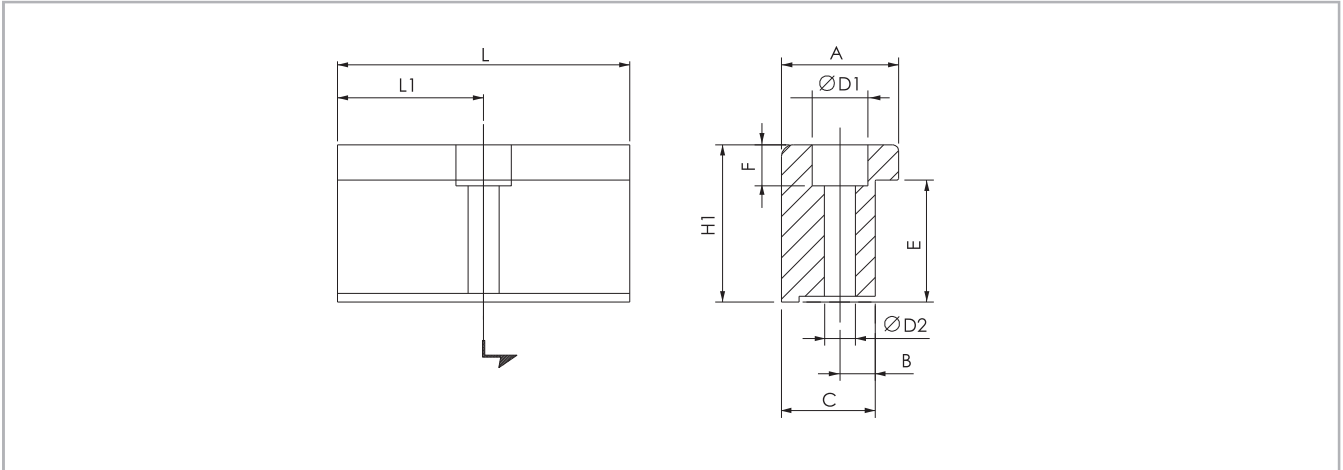

Anodized aluminum block for fixing the linear units through the side slots of the body

Fig. 13

Unit	A	H1	B	C	E	F	D1	D2	L	L1	Code
ECO 60	20	17.5	6	16	11.5	6	9.4	5.3	50	25	1001490
ECO 80	20	20.7	7	16	14.7	7	11	6.4	50	25	1001491
ECO 100	36.5	28.5	10	31	18.5	11.5	16.5	10.5	100	50	1001233

Tab. 22

T-nuts

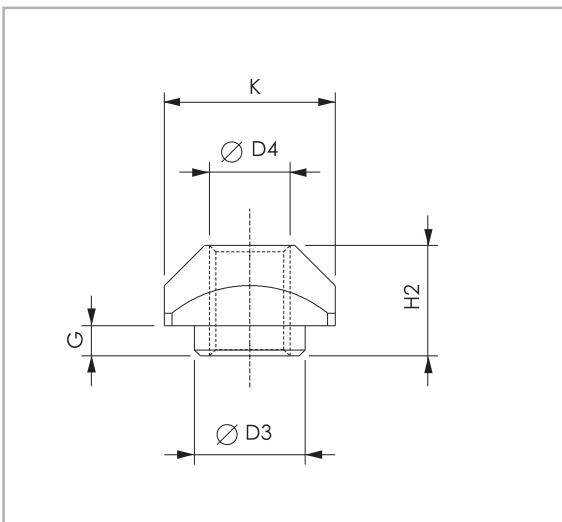

Steel nuts to be used in the slots of the body.

Fig. 14

Dimensions (mm)

Unit		D3	D4	G	H2	K	Code
ECO 60	S	6.7	M5	2.3	6.5	10	1000627
ECO 60	C	-	M5	-	5	10	1000620
ECO 80	S	8	M6	3.3	8.3	13	1000043
ECO 80	C	-	M6	-	5.8	13	1000910
ECO 80	L	-	M6	-	6.5	17	1000911
ECO 100	S	11	M8	3	11	17	1000932
ECO 100	C	-	M8	-	8	16	1000942
ECO 100	L	-	M8	-	6.5	17	1000943

S = Side - C = Carriage - L = Lower

Tab. 23

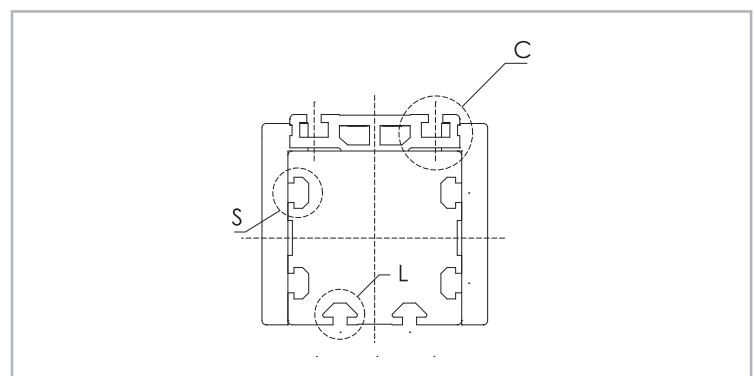

Fig. 15

Proximity

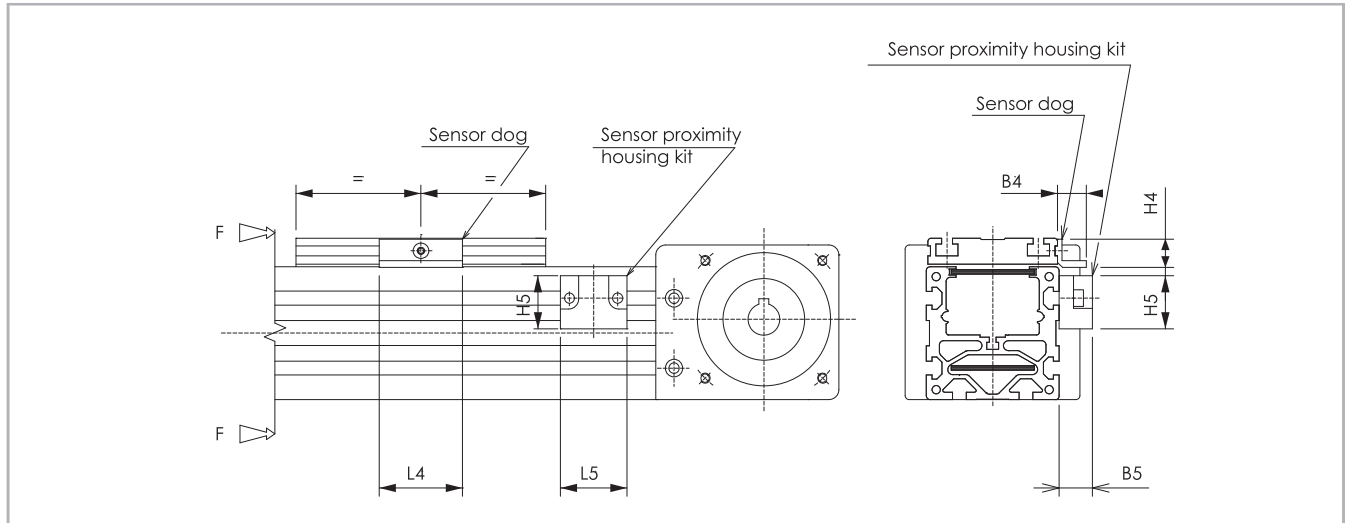

Fig. 16

**Sensor proximity housing kit**

Anodized aluminum block, red colour, equipped with T-nuts for fixing into the body slots.

**Sensor dog**

L-shaped bracket in zinc-plated iron, mounted on the carriage and used for the proximity switch operation.

Unit	B4	B5	L4	L5	H4	H5	For proximity	Sensor dog Code	Sensor proximity housing kit code
ECO 60	9.5	14	25	29	12	22.5	Ø 8	G000268	G000213
ECO 80	17.2	20	50	40	17	32	Ø 12	G000267	G000209
ECO 100	17.2	20	50	40	17	32	Ø 12	G000267	G000210

Tab. 24

# Ordering key

## > Identification codes for the ECO linear unit

C	06 06=60 08=80 10=100	2A	0 2000	1A 1A=SP1 2A=SP2 1C=CI	
					Linear motion system <i>see pg. ES-4</i>
					L=total length of the unit
					Driving head code <i>see pg. ES-8</i>
					Linear unit size <i>see from pg. ES-5 to pg. ES-7</i>
					ECO series <i>see pg. ES-2</i>

In order to create identification codes for Actuator Line, you can visit: <http://configureactuator.rollon.com>



### Left / right orientation

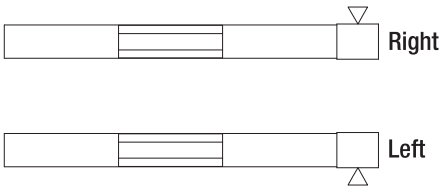

## Multiaxis systems



Previously, customers wishing to build multiaxis units have had to design, draw and manufacture all the elements necessary to assemble two or more axis. Rollon now offers a set of fittings including brackets and cross plates to enable multiaxis units to be built. In addition to standard elements, Rollon also provides plates for special applications.

### ECO axis system



A - Linear units: X axis 1 ECO 80

### Two axis X-Y system



B - Linear units: X axis: 2 ECO 80 - Y axis 1 ECO 80

**Connection kit:** 2 Kits of fixing brackets for the ECO 80 unit (Y axis) on the carriages of the ECO 80 units (X axis).