



# R4 Rotary Latch

Light-Duty · Concealed · Single and two stage

## Single Stage - Top

(left hand actuation shown)

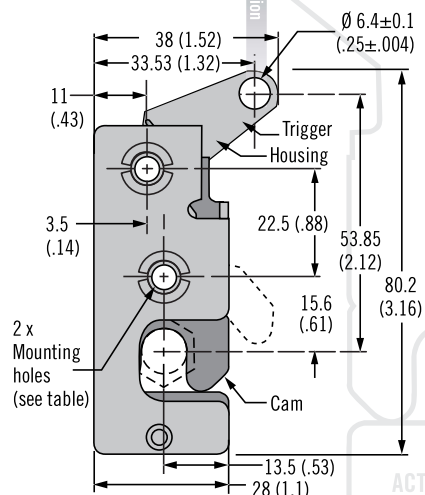

## Integrated Bumper Version

(dimensions same as standard version except as shown)

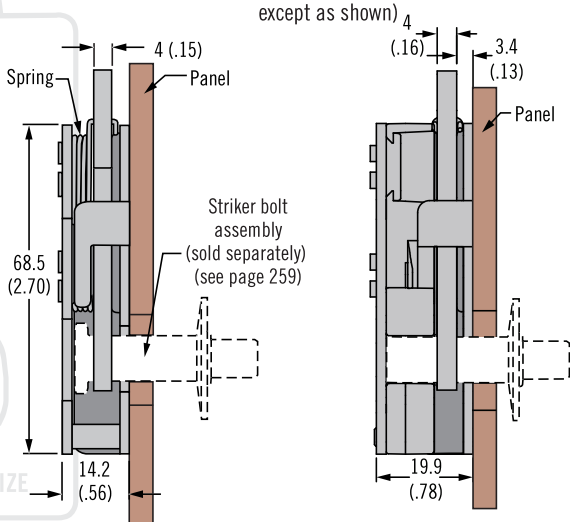

## Single Stage - Direct Actuation

(left hand actuation shown)

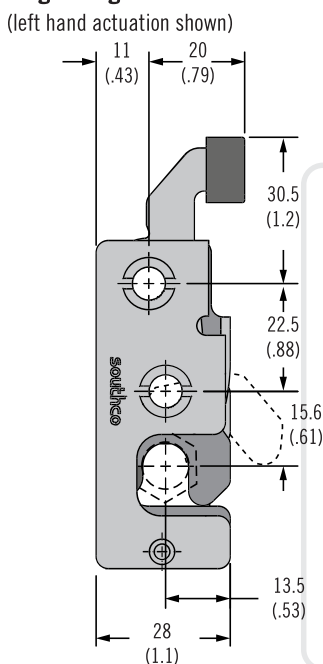

## Integrated Bumper Version

(dimensions same as standard version except as shown)

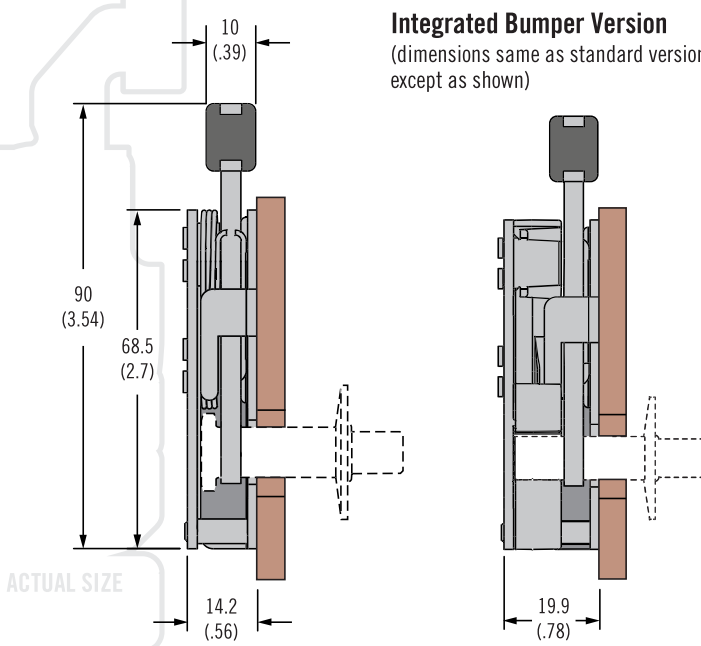

- Compatible with wide array of actuators
- EN 45545-3 E60 Compliant (Standard version only)
- Integrated bumper version for anti-vibration feature



### Material and Finish

Steel, zinc plated

### Accessories

Striker bolts for standard version and integrated bumper version are different. See page 297 for both versions.

Cables and retainer clips see page 322-323

Trigger - use retaining clip R4-0-43922-2

Lever - use retaining clip R4-0-43922

### Notes

Electromechanical rotary latch available see page 20

### Part Number Selection

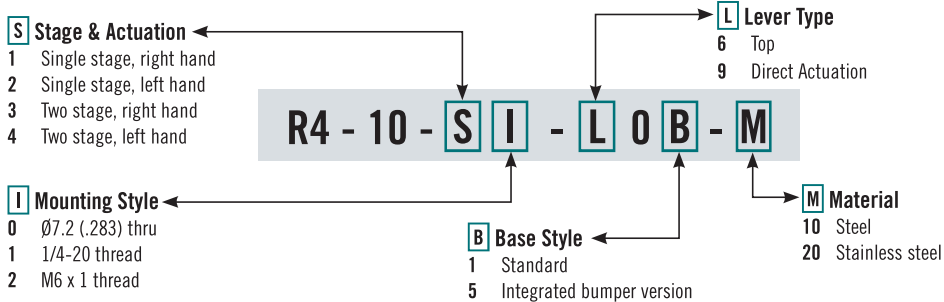

Dimensions in millimeters (inch) unless otherwise stated

[www.southco.com/R4](http://www.southco.com/R4)