

R4-82 Rotary Paddle Latch

Pull-to-open

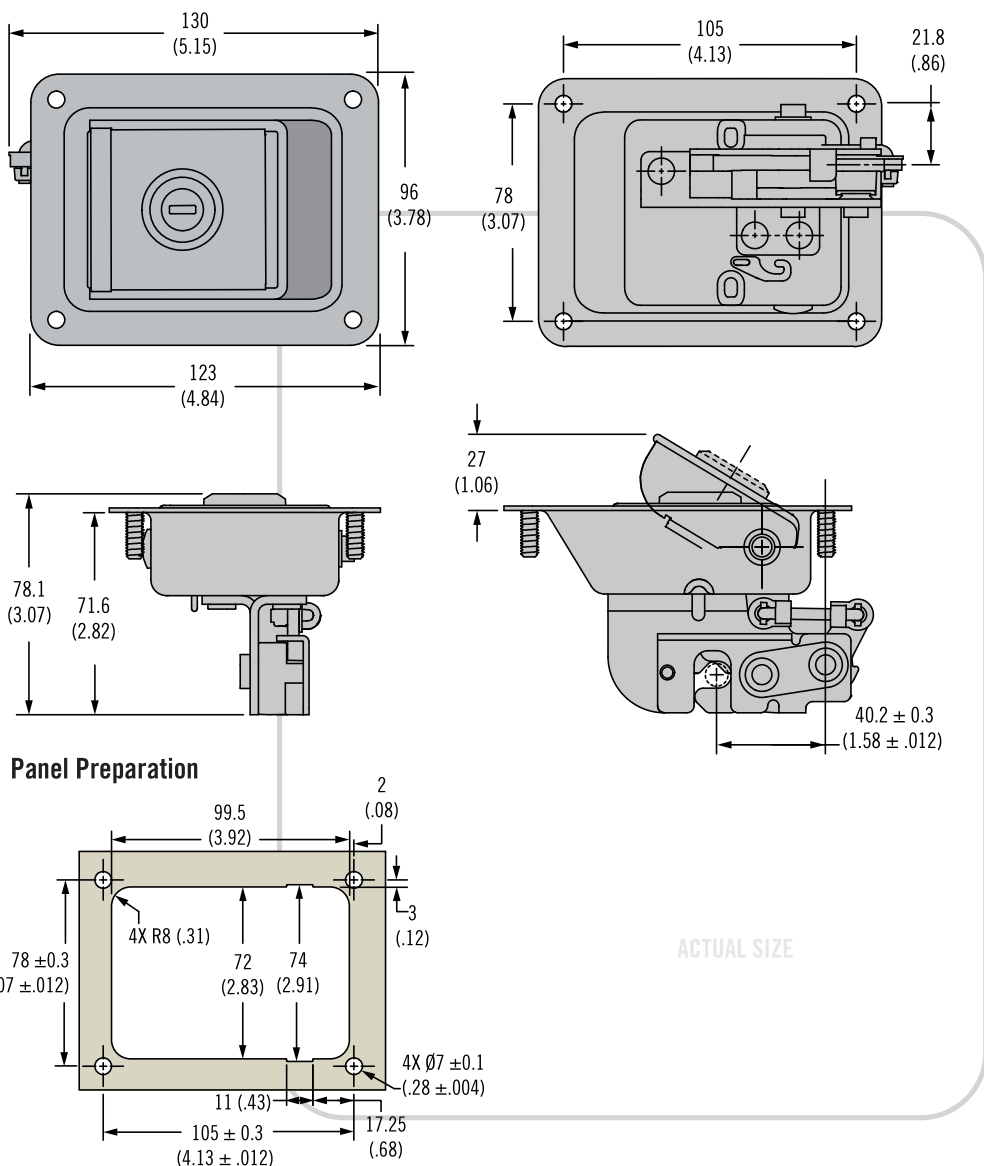

- Direct actuation, no cable or rod required
- Single or two stage latching
- Integrated bumper
- Thru hole or stud mounting options

Material and Finish

Cup and handle: Steel, zinc plated or black powder coat

Lock slide, latch frame, pawl, trigger: Steel, zinc plated

Installation Notes

Thru hole: M5 or #8 screws recommended

Studs: Use M6 mounting nuts (max tightening torque 7 N·m (62 in·lbf))

Studs: Max panel thickness 10 (.39)

Accessories

Striker bolt see page 297

Notes

For lock core selection and a complete overview of the *SOUTHCO*® Key-Choice System see page 190

Part Number Selection

See table

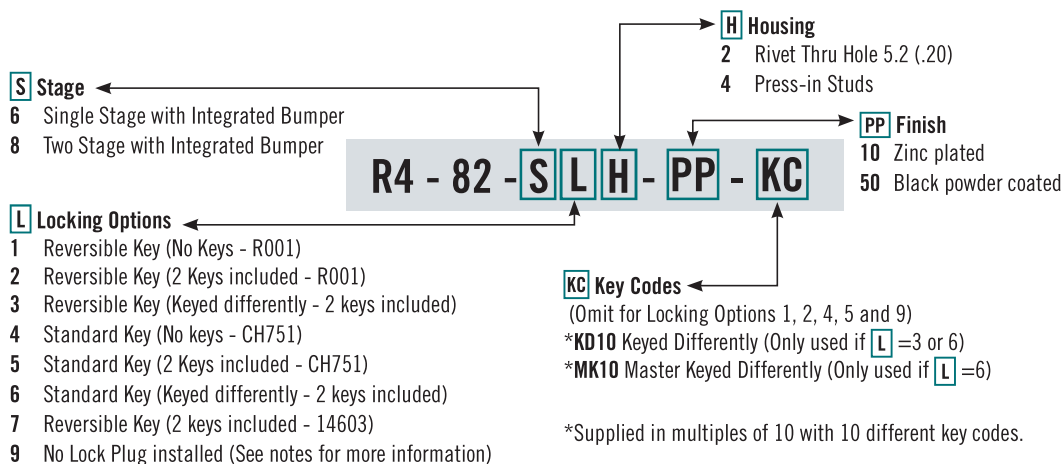

Dimensions in millimeters (inch) unless otherwise stated

www.southco.com/AC