

TRUNK HANDLE

TEST METHOD 1



MUD-140



Features

- Spring powered to automatically close when hands are removed.

Parts Included

M5x8 truss head screw

Cut Out Dimensions

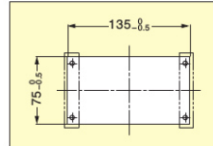

Mounting Application

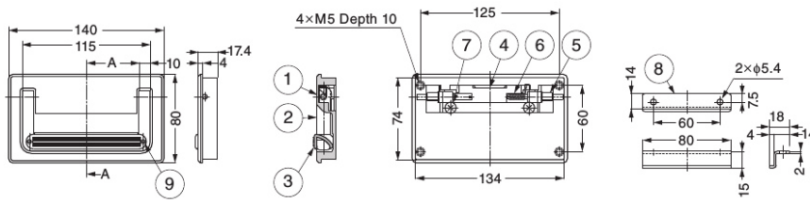
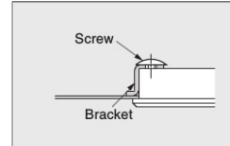

No.	Part Name	Material	Finish/Colour
①	Body	Zinc Alloy (ZDC)	Chrome
②	Handle	Zinc Alloy (ZDC)	Chrome
③	Grip	Elastomer (TPE)	Black
④	Back Cover	Steel (SPCC)	Yellow Zinc Chromate
⑤	Shaft	Zinc Alloy (ZDC)	Yellow Zinc Chromate
⑥	Spring	Steel (SWPB)	Yellow Zinc Chromate
⑦	Screw	Steel (SWCH)	-
⑧	Bracket	Steel (SPCC)	Yellow Zinc Chromate
⑨	Screw	Stainless Steel	Black

Item Code	Item Name	Load Capacity	Weight	Box	Carton
100-901-272	MUD-140	294 N	30 kgf	620 g	5 pcs / 20 pcs

TRUNK HANDLE

TEST METHOD 1

PT-148



Features

- Spring powered to automatically close when hands are removed.

Cut Out Dimensions

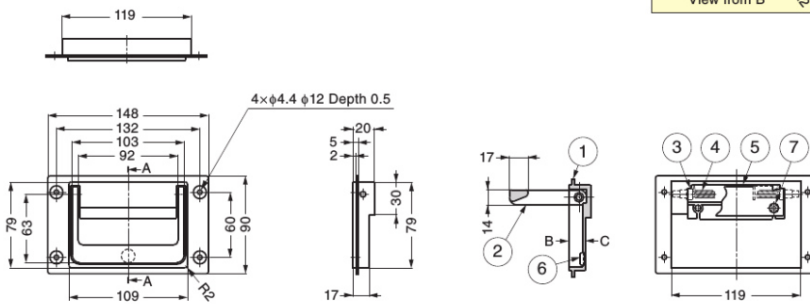
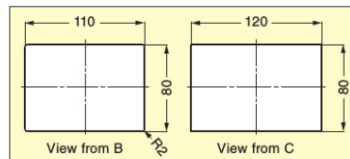

No.	Part Name	Material	Finish/Colour
①	Body	Zinc Alloy (ZDC)	Grey
②	Handle	Zinc Alloy (ZDC)	Grey
③	Shaft	Steel	Plain
④	Spring	Steel	Clear Zinc Chromate
⑤	Back Cover	Steel	Yellow Zinc Chromate
⑥	Bumper	Polyurethane (PUR)	Clear
⑦	Countersunk Head Screw	Steel	Yellow Zinc Chromate

Item Code	Item Name	Load Capacity	Weight	Box
100-019-183	PT-148	490 N	50 kgf	645 g / 20 pcs

HANDLES,
PULLS & KNOBS

TRUNK HANDLE